



Universidad de  
Oviedo



**ESCUELA POLITÉCNICA DE INGENIERÍA DE GIJÓN.**

**GRADO EN INGENIERÍA MECÁNICA**

**ÁREA DE MECÁNICA DE MEDIOS CONTINUOS Y TEORÍA DE  
ESTRUCTURAS**

**APLICACIONES DE LA IMPRESIÓN 3D EN LA INGENIERÍA  
HIDRÁULICA**

**D. ARIZA GARCÍA, Alejandro**  
**TUTOR: D. Miguel Ángel Serrano López**

**FECHA: Julio 2017**

## ÍNDICE

|   |   |
|---|---|
| 1. INTRODUCCIÓN .....                                     | 1 |
| 2. FABRICACIÓN ADITIVA .....                              | 2 |
| 3. FABRICACIÓN ADITIVA EN LA INGENIERÍA CIVIL .....       | 5 |
| 3.1. ESPECIFICACIONES PARA LA CONSTRUCCIÓN CIVIL .....    | 5 |
| 3.2. EJEMPLOS DE APLICACIÓN EN LA INGENIERÍA CIVIL .....  | 5 |
| 4. POSIBLES APLICACIONES EN LA INGENIERÍA HIDRÁULICA..... | 7 |
| 5. CONCLUSIONES .....                                     | 8 |

# 1. INTRODUCCIÓN

Todos los objetos usados por el hombre, cumplen dos requisitos. Todo está hecho a partir de unos materiales y dichos materiales siguen un determinado de fabricación para conseguir una determinada forma y calidades finales.

En los últimos años, nuevas tecnologías de fabricación han surgido como alternativa a los procesos de fabricación tradicionales, tales como fresado, forjado o laminado, en donde se utilizan diferentes herramientas, lubricantes o fluidos de corte, así como el coste y el tiempo de fabricación es importante. A diferencia de los procesos de mecanizado, donde se elimina material para llegar a la forma final, estas nuevas tecnologías añaden material para obtener el producto capa a capa. Sólo se necesita una impresora 3D y el archivo CAD de la pieza.

Respecto a este proyecto, muchas ramas de la ingeniería han utilizado estas tecnologías, y la ingeniería civil no es una excepción. Por ejemplo, en China se ha construido el primer bloque de pisos mediante la impresión 3D, o en España, donde un puente se ha construido con esas mismas tecnologías. En ambos casos, no fue necesario el uso de andamios para mantener en pie la construcción.

## 2. FABRICACIÓN ADITIVA

La fabricación aditiva, también conocida como impresión 3D, consiste en la obtención de piezas a partir de añadir una materia prima capa a capa, en la que se utiliza un archivo CAD de una pieza en 3D, a dicho modelo se le aplica una división por capas, para que por medio de un sistema CAM, se obtengan las trayectorias que debe seguir la herramienta para obtener dichas capas, tal y como muestra la Figura 1.



Figura 1. Proceso para la obtención de una pieza por fabricación aditiva

A pesar de considerarse una alternativa, sus inconvenientes son importantes a tener en cuenta a la hora de querer crear un objeto. El coste total, incluyendo las máquinas, es elevado, así como el tiempo de fabricación, ya que es un proceso lento. Además, la funcionalidad de los objetos no se cumple, al tener de manera frecuente unas propiedades mecánicas peores comparadas con el mecanizado, por ejemplo. Por otro lado, las propiedades de los objetos son anisótropas, las cuales pueden suponer un problema, dependiendo del uso de dicha pieza, ya que las propiedades varían según la dirección donde se aplican esfuerzos.

En la impresión 3D, las tecnologías más comunes utilizadas son:

- Estereolitografía (SLA)
- Modelado por deposición fundida (FDM)
- Sinterizado selectivo por láser (SLS)
- Fabricación de partículas balísticas (3DP)

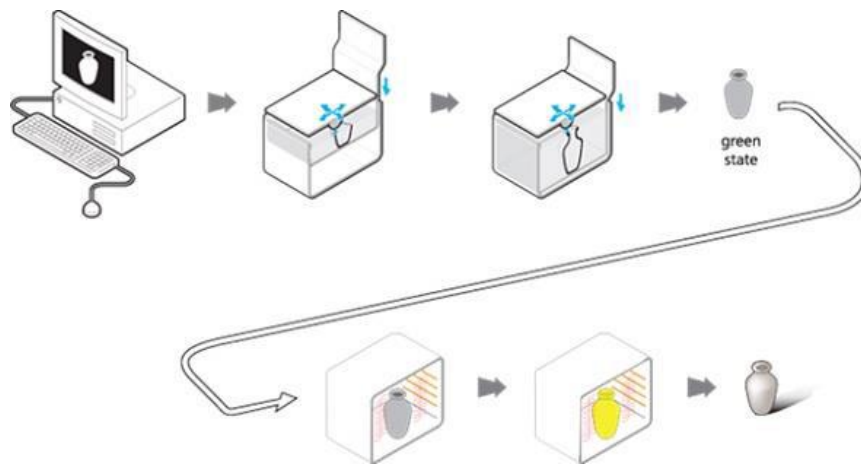
- Moldeado Polyjet (MJM)
- Fabricación de objetos laminados (LOM)

Las aplicaciones de la impresión 3D son muy variadas. Se pueden imprimir objetos cotidianos, como tazas para el café, implantes médicos, prótesis, así como ropa, armas, e incluso comida.

Cada una de estas tecnologías usa diferentes materiales, comúnmente se utilizan termoplásticos, metales y cerámicos. Si tomamos en cuenta el proyecto, muchas de las construcciones tanto en obra civil como hidráulica están hechas de hormigón.

El hormigón es considerado como un material nuevo en la impresión 3D, el cual se imprime de una manera similar a FDM, según la Figura 2.



Figura 2. Proceso de impresión 3D del hormigón

La principal característica es que se imprime sin uso de encofrado. Sin embargo, muchas de las construcciones son de hormigón armado, por lo que la armadura, si es de acero, no se puede imprimir de la misma manera que el hormigón. Una opción a considerar es imprimir la capa de hormigón, y colocarle posteriormente la armadura sobre esta. Debido al esfuerzo que puede ocasionar este procedimiento, otra alternativa a tener en cuenta es la utilización de fibras de hormigón armado. Las fibras más comunes a utilizar son de plástico, acero y vidrio. Las fibras de plástico suelen estar hechas de polipropileno, que destaca por una alta resistencia a la fractura. Se distinguen dos tipos: microfibras y macrofibras. Las microfibras se colocan sobre el hormigón no fraguado, la cual influye en el tiempo de secado de hormigón. Poseen una alta resistencia al fuego, así como al desgaste y a la escarcha. Respecto a las microfibras, estas mejoran las propiedades mecánicas del hormigón, y forman una

superficie corrugada, la cual mejora las transmisiones de esfuerzos entre el hormigón y las fibras. Además, puede reemplazar en su totalidad la armadura, especialmente en construcciones con una atmósfera agresiva o en construcciones herméticas, debido a la corrosión del acero a causa del agua.

Respecto a las fibras de acero, se ha de tener en cuenta la velocidad de oxidación para obtener los componentes necesarios. Pueden ser colocadas en cualquier construcción, pero no todas las fibras contribuyen a la distribución de esfuerzos.

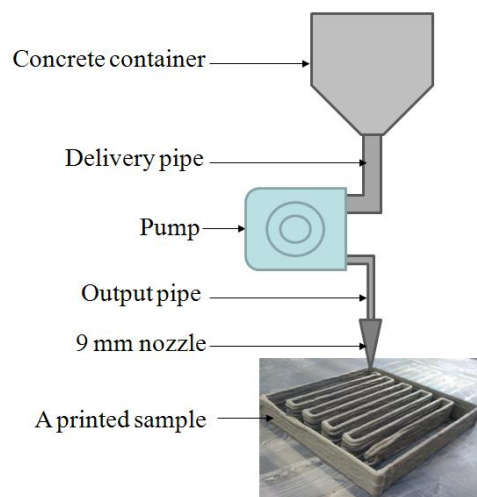
Las fibras de vidrio muestran características sólidas, así como de fluencia. Estas fibras tienen un comportamiento elástico, y la fractura ocurre entre el 2 y el 5% de la deformación. El principal inconveniente es la compatibilidad con la pasta de cemento, la cual es alcalina. De ahí se distinguen dos tipos de fibras: fibras resistentes alcalinas y resistentes no alcalinas. Las primeras se obtienen mediante estirado del vidrio fundido, y con un posterior recubrimiento se protege del ataque del cemento. Las segundas son solubles en hormigón no fraguado, por lo que son efectivas durante un tiempo, y hace que la estructura sea más frágil.

### 3. FABRICACIÓN ADITIVA EN LA INGENIERÍA CIVIL

#### 3.1. ESPECIFICACIONES PARA LA CONSTRUCCIÓN CIVIL

Como se ha explicado en el capítulo 2, el material utilizado en su mayoría para la construcción civil es el hormigón. La principal característica es la ausencia de encofrado para su impresión. Freeform Construction es un conjunto de tecnologías utilizadas en la impresión 3D para imprimir estructuras de hormigón de grandes dimensiones. Como su nombre indica, la geometría de la construcción es de libre elección, el coste podría ser menor que el de una construcción convencional, y el procedimiento sería más preciso.

Contour Crafting es una de esas tecnologías que forman Freeform Construction. Tal como muestra la Figura 3, el inyector está sujeto a una grúa puente, que se mueve en dos carriles paralelos. El inyector tiene 6 posiciones, puede extruir ambos lados con material de relleno.



Figura 3. Contour crafting

En esta tecnología, es necesario instalar la armadura y colocar el hormigón para imprimir capas con un máximo de 20 mm de altura. Concrete Printing surge como una solución a estas necesidades, en la que la impresora tiene un pórtico de 5.4m x 4.4m (huella) x 5.4m (altura) y un cabezal de impresión, donde se coloca el inyector para proporcionar el material a extrudir.

#### 3.2. EJEMPLOS DE APLICACIÓN EN LA INGENIERÍA CIVIL

Las aplicaciones de la impresión 3D en la ingeniería civil están reducidas a la construcción de edificios y de puentes. Las casas se imprimen en componentes separados, para posteriormente formar un conjunto. Freeform Construction imprime los componentes estructurales, pero no otros componentes adicionales, ya sean instalaciones eléctricas, o redes de tuberías. Un ejemplo lo tenemos en China, donde una compañía de nombre WinSun ha

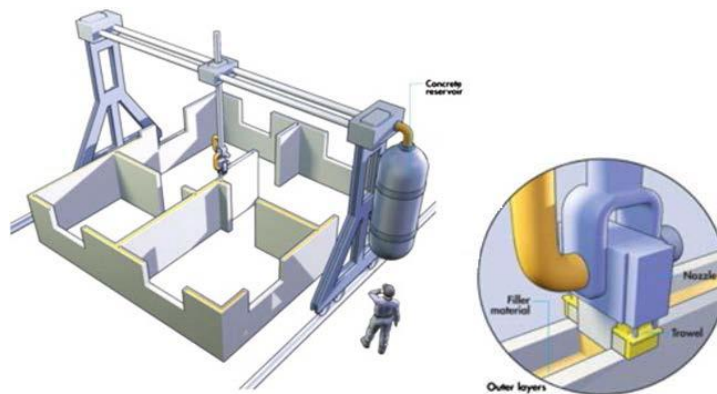
construido por medio de la impresión 3D bloques de pisos. Esta compañía afirmaba que las casas cumplían con los requisitos establecidos en las normas nacionales, uno de los principales objetivos para imprimir casas.

Respecto a la impresión de puentes, España es el país pionero en el mundo. Un equipo de investigación del Institute of Advance Architecture of Catalonia (IAAC), ha creado un puente (Figura 4) usando capas de hormigón armado con microfibras de polipropileno.



Figura 4. Puente construido mediante impresión 3D en Madrid



## 4. POSIBLES APLICACIONES EN LA INGENIERÍA HIDRÁULICA

Respecto a la ingeniería hidráulica, las estructuras más comúnmente construidas son las presas y las máquinas de fluidos.

El 85-90% de las presas construidas son presas de materiales sueltos, debido a razones técnicas y económicas. Sin embargo, aparte del coste, atendiendo a las presas rellenas de materiales de tierra (ing.: Earthfill embankment dam), estas no pueden construirse mediante impresión 3D, debido a que los materiales utilizados no son, por el momento, imprimibles. Respecto a las presas rellenas de materiales rocosos (ing.: Rockfill embankment dam), es posible imprimir los elementos de sellado, si estos son de hormigón mediante Contour Crafting.

Por otro lado, la mayoría de las máquinas de fluidos están hechas de metal, comúnmente de superaleaciones. Las únicas tecnologías posibles a utilizar son SLS y 3DP, mencionadas en el capítulo 2. Habría que tener en cuenta las dimensiones límite de ambas tecnologías, así como la necesidad de aplicar sinterización para obtener piezas sin porosidad y con una suficiente resistencia. Tras la impresión, es necesario aplicar tratamientos y recubrimientos superficiales, para dotar a las máquinas de una gran resistencia contra partículas extrañas, ya sean piedras o gravilla, que puedan aparecer en la corriente de un flujo. En el caso de las cubiertas de las turbinas hechas de hormigón, es posible imprimirlas mediante Contour Crafting.

Finalmente, acerca de modelos utilizados para análisis dimensional, se toma de referencia el número adimensional de Froude, ya que las corrientes generadas en estas son similares a fluidos en canal abierto. Además de esto, al no cumplirse al mismo tiempo las condiciones de similitud cinemáticas y dinámicas, es aconsejable considerar la similitud cinemática en las máquinas de fluidos y la similitud dinámica en las presas. Debido a la deposición de capas, los modelos pueden tener una cierta rugosidad, la cual genera grandes efectos de escala en los prototipos, por lo que conviene aplicar procesos de acabado, como fresado o pulido para obtener superficies lisas y evitar dichos efectos.

## 5. CONCLUSIONES

El proyecto resume las posibilidades de aplicar la impresión 3D en la ingeniería hidráulica, tomando en cuenta los materiales, las tecnologías disponibles, la maquinaria y las diferentes estructuras existentes actualmente. Los temas más importantes son resumidos de esta manera:

- La fabricación aditiva es una alternativa a los procesos de fabricación y a las tecnologías de construcción utilizadas hoy en día. Se ha desarrollado en poco tiempo, pero deberá desarrollarse más para que sea una alternativa fiable.
- La mayoría de los objetos creados mediante impresión 3D están hechos de termoplásticos, debido a su fácil acceso en cuanto a costes y a manejabilidad.
- La ausencia de armadura en la impresión del hormigón es un tema muy importante, y es necesario encontrar aditivos o materiales para añadir al hormigón, y que sea armado e imprimible al mismo tiempo.
- Respecto a las estructuras hidráulicas, es posible imprimir turbinas y propulsores, así como modelos a escala, cumpliendo siempre con los límites de las tecnologías aplicadas.
- Otras estructuras como presas no son posibles por el momento de construir mediante impresión 3D, debido a que los materiales actuales usados para su construcción no son imprimibles.

ARIZA GARCÍA Alejandro

# 3D-PRINTING APPLICATIONS IN HYDRAULIC ENGINEERING

## BACHELOR THESIS

submitted to

LEOPOLD-FRANZENS-UNIVERSITÄT INNSBRUCK  
FACULTY OF ENGINEERING SCIENCE

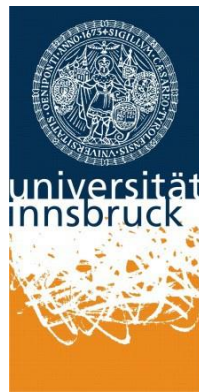

to get the academic qualification

BACHELOR OF SCIENCE

Advisor:

Dipl.-Ing. Dr. KLAR Robert

Department of Infrastructure  
Unit for Hydraulic Engineering

Innsbruck, July 2017

## **Acknowledgments:**

In first place, I would like to thank to Universität Innsbruck to allow me to do this research project, especially to my tutor Robert Klar for giving me the chance to do it, and her colleague Diana López to make me easier the way to do my thesis.

I do not forget also my home university of Spain, and my Erasmus coordinator Miguel Serrano for showing me a so wonderful city like Innsbruck, and my friend Daniel who recommend me to stay the whole year of the Erasmus.

**Abstract:**

The implantation of 3D printing in the civil engineering is supposed to start a revolution in the way to build structures. In recent years, buildings have been built through 3D printing technologies using concrete without reinforcement, or not even load bearing structures like bridges. However, it has not been tested yet in the field of hydraulic engineering. The main goal of this thesis, is to find applications of 3D printing technologies in this engineering field, and to determine whether technologies and materials used here are feasible solutions, both for functionality and profitability.

**Kurzfassung:**

Die Technik des 3D Drucks hat sich gerade zu revolutionär entwickelt in den letzten Jahren bis hin zu Verfahren für den Bau von Tragwerken. Sowohl die Errichtung von Gebäuden aus Beton ohne Bewehrung als auch von Brücken ist heute möglich. Im Wasserbau steht die Erprobung der neuen Technologien jedoch noch bevor. Die Hauptziele dieser Arbeit sind das Finden vielversprechender Anwendungen des 3D Drucks im Wasserbau und das Treffen einer ersten Abschätzung, ob die derzeit angehen Technologien und Materialien dafür geeignet wären.

## INDEX

|        |   |    |
|--------|---|----|
| 1.     | INTRODUCCIÓN .....  | 1  |
| 2.     | FABRICACIÓN ADITIVA .....   | 2  |
| 3.     | FABRICACIÓN ADITIVA EN LA INGENIERÍA CIVIL .....                                  | 5  |
| 3.1.   | ESPECIFICACIONES PARA LA CONSTRUCCIÓN CIVIL .....                                 | 5  |
| 3.2.   | EJEMPLOS DE APLICACIÓN EN LA INGENIERÍA CIVIL .....                               | 5  |
| 4.     | POSIBLES APLICACIONES EN LA INGENIERÍA HIDRÁULICA .....                           | 7  |
| 5.     | CONCLUSIONES .....  | 8  |
| 1.     | INTRODUCTION .....  | 1  |
| 2.     | ADDITIVE LAYER MANUFACTURING .....  | 2  |
| 5.1.   | WHAT IS ADDITIVE LAYER MANUFACTURING? .....                                       | 2  |
| 5.2.   | TYPES OF ADDITIVE MANUFACTURING TECHNOLOGIES <sup>[1]</sup> .....                 | 3  |
| 5.2.1. | STEREOLITHOGRAPHY (STL) .....   | 3  |
| 5.2.2. | FUSED DEPOSITION MODELLING (FDM) .....  | 4  |
| 5.2.3. | SELECTIVE LASER SINTERING (SLS) .....   | 5  |
| 5.2.4. | BINDER JETTING (3DP) .....  | 7  |
| 5.2.5. | MULTIJET/POLYJET MODELLING (MJM) .....  | 8  |
| 5.2.6. | LAMINATED OBJECT MANUFACTURING (LOM) .....  | 9  |
| 5.3.   | MATERIALS USED IN ADDITIVE MANUFACTURING .....                                    | 11 |
| 5.3.1. | THERMOPLASTIC <sup>[2][3]</sup> .....   | 11 |
| 5.3.2. | METALS <sup>[2][5]</sup> .....  | 12 |
| 5.3.3. | CONCRETE <sup>[6]</sup> .....   | 14 |
| 5.4.   | GENERAL 3D PRINTING APPLICATIONS .....  | 19 |
| 3.     | 3D PRINTING IN CIVIL ENGINEERING .....  | 24 |
| 3.1.   | SPECIFICATIONS FOR CIVIL STRUCTURES <sup>[10]</sup> .....                         | 24 |
| 3.2.   | CIVIL ENGINEERING APPLICATIONS <sup>[10]</sup> .....                              | 26 |
| 4.     | APPLICATIONS IN HYDRAULIC ENGINEERING .....                                       | 28 |
| 4.1.   | INTRODUCTION .....  | 28 |
| 4.2.   | DAMS <sup>[14]</sup> .....  | 28 |
| 4.3.   | FLUID MACHINERY <sup>[16]</sup> .....   | 33 |
| 4.4.   | MODELS OF HYDRAULIC STRUCTURES .....  | 37 |
| 4.4.1. | INTRODUCTION .....  | 37 |
| 4.4.2. | SCALED PHYSICAL MODELLING OF HYDRAULIC STRUCTURES<br>(DIMENSIONAL ANALYSIS) ..... | 37 |
| 4.4.3. | GEOMETRIC SIMILARITY CONDITION <sup>[19]</sup> .....                              | 39 |
| 4.4.4. | KINEMATIC SIMILARITY CONDITION <sup>[20]</sup> .....                              | 40 |
| 4.4.5. | DYNAMIC SIMILARITY CONDITIONS <sup>[20]</sup> .....                               | 40 |

|        |   |    |
|--------|---|----|
| 4.4.6. | SIMILARITY WITH FROUDE AND REYNOLDS <sup>[20]</sup> .....       | 42 |
| 4.4.7. | SCALE EFFECTS <sup>[20]</sup> .....                             | 42 |
| 4.5.   | FEASIBILITY OF USING 3D PRINTING IN HYDRAULIC ENGINEERING ..... | 43 |
| 5.     | CONCLUSIONS.....  | 45 |
|        | REFERENCES.....   | 46 |

# 1. INTRODUCTION

Everything we have or use, fulfills two premises: the first one is that all is made of materials, and the second one is that those materials follow a certain manufacturing process to reach the final shape and qualities.

In recent years, new manufacturing technologies have arisen to be an alternative to traditional ways as machining, rolling or forging, which use a substantial amount of tools, lubricant or cutting fluids, as well as the costs and the time needed in these processes. Instead of removing material to obtain final products, those new technologies add material to obtain that final product layer by layer. Only for that it is needed a 3D printer and the CAD file of the model.

Regarding this project, most of the engineering fields have used these manufacturing technologies and civil engineering is not an exception. For instance, in China the first apartment building was built through 3D printing technology, or in Spain, where a bridge has been built with the same technology. In both cases, it was not necessary to use scaffoldings to keep standing the works.



## 2. ADDITIVE LAYER MANUFACTURING

### 5.1. WHAT IS ADDITIVE LAYER MANUFACTURING?

Additive layer manufacturing, also known as 3D printing, is a type of manufacturing process, which consists in create a model adding raw material layer by layer. For that, the original model is designed through CAD<sup>A</sup> program, such as Autodesk Inventor, Solid Edge or Solid Works. Then, this model is brought to a specific software, which slices the model geometry into layers. Finally, with a CAM<sup>B</sup> system, they generate the paths that the printer must follow for each layer. Figure 1, shows this process.

Although it is an alternative to the traditional manufacturing ways, there are disadvantages to consider at the time to create an object. Commonly, the total cost, including machines and materials, is high. Furthermore, the process is slower than machining, and the functionality of these objects is not fulfilled, that is, the mechanical properties are often worse in 3D printing than machining, and 3D printing generates anisotropy properties, which may makes an object stiffness worse in certain directions.



Figura 5. 3D printing computational steps (i.materialise.com)

<sup>A</sup> Computer Aided Design

<sup>B</sup> Computer Aided Manufacturing

| PROS   | CONS   |
|--|--|
| Part construction layer by layer (not waste of material)                                 | High cost (equipment and consumables)  |
| Use of CAD systems to generate part geometry   | Slow processes   |
| Use of software for geometry division into layers (slices)                               | Wide dimensional tolerances (more than $\pm 0.05$ mm)                                |
| Use of CAM system to generate the tool paths of CNC <sup>C</sup> manufacturing equipment | Worse physical and mechanical properties than those obtained by machining or forming |
| High pre- and post-processing times  | Anisotropic properties may be a problem  |

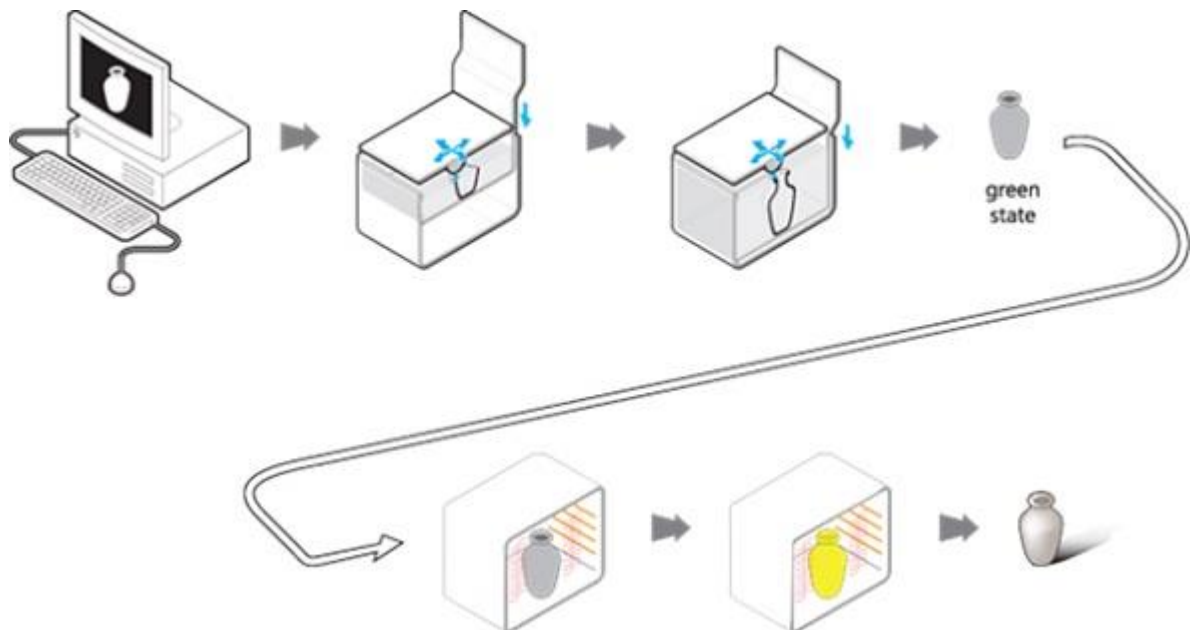
Table 1. Pros and cons of the additive manufacturing technologies

## 5.2. TYPES OF ADDITIVE MANUFACTURING TECHNOLOGIES <sup>[1]</sup>

### 5.2.1. STEREOLITHOGRAPHY (STL)

Shortened as STL, it is one of the most frequent technologies used. It consists in hardening a liquid photopolymer, which is a mixture of acrylic monomers, oligomers and a photo initiator, into a specific shape. A platform is in the top of the vat, while an ultraviolet light source is pointed to the area. The platform is covered by a weak support material, which is easily removed when the modeling is done. When the light source is pointed to an area, this one is cured by the photopolymer with the layer thickness. Then, the platform goes down, and the process is repeated until the model is done. After that, the part is subjected to a final curing cycle in an oven. The smallest tolerance reached with this technology is around 0.0125 mm. Figure 2 shows the process.

The manufacturing time is variable, but the interval is between few hours and one day, without taking into account finishing processes. Because of the time, the machine cost is between 100,000 and 400,000 \$, and the liquid polymer cost is around 80 \$ per litre. The maximum dimensions of a part created by stereolithography is 0.5 m x 0.5 m x 0.6 m.

---

<sup>C</sup> Computer Numerical Control



Figura 6. STL process (Kalpakjian, S., & Schmid, S. R., 2014)

Applications:

- Medical/dental products
- Electronics casting
- Investment casting patterns
- Art

### 5.2.2. FUSED DEPOSITION MODELLING (FDM)

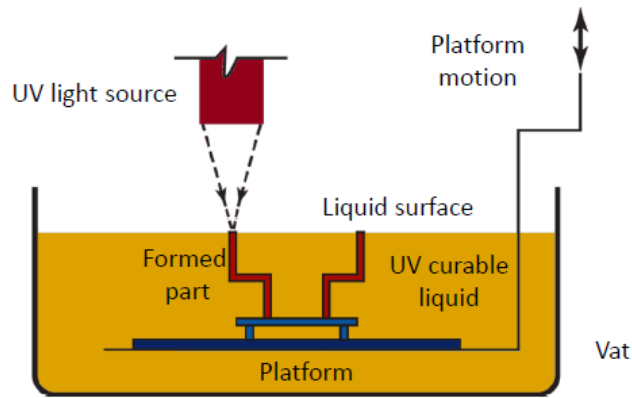
Shortened as FDM, it is the most common technology used. It uses a thermoplastic filament, which is extruded from the small hole of a heated die. Each filament extruded forms a layer of the model, which is placed on a foam foundation while it follows the programmed path. After the first layer is done, the table where the foundation and the model are placed, goes down to repeat the process until the part is created.

In some cases, complicated parts are not possible to manufacture in one process. To solve that, the support material is extruded separately from the modelling material, with a less dense filament spacing on a layer, to be easily broken after finishing the final model. Figure 3 shows how FDM works.

FDM layers depend on the extruder diameter, which ranges from 0.05 to 0.12 mm. This is at the same time the best reached tolerance in the vertical direction. In the x-y plane dimensional accuracy reaches 0.025 mm.

About the raw materials, the most common are ABS, polycarbonate and polysulfone. In other cases, the filament can be another material, like metal in *Flat wire metal deposition*, although then a laser is needed to heat and additionally bond the deposited wire to build parts.

In this technology, finishing operations are needed because of the resulting surface roughness. Most common are coatings through polishing wax and sanding by hand. That finishing operations are applied after heating the model to smooth the surface.

The machine costs depend on the size of the manufactured parts and the numbers and types of materials useful in those machines. With that, the interval oscillates between 20,000 \$ and 300,000 \$.



Figura 3. FDM process (Kalpakjian, S., & Schmid, S. R., 2014)

Applications:

- Electronic housing
- Mounts
- Custom consumer products

### 5.2.3. SELECTIVE LASER SINTERING (SLS)

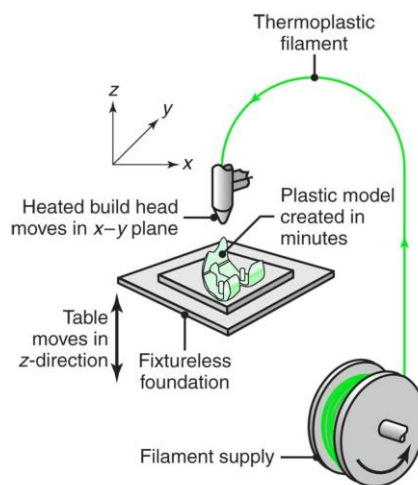
Shortened as SLS, is based on the sintering of nonmetallic or metallic powders selectively brought into an individual shape. The machine used consists of a chamber connected to the computer through wires, which contain the laser and the galvanometers used for the sintering

laser. There are two cylinders on the ground of the chamber, as shows Figure 4 with all the process.

- The left one is a powder feed cylinder, which goes up to supply powder to the roller mechanism
- The right one is a part-build cylinder, which goes down after each layer is completed to create the model.

In first place, the roller mechanism passes over the powder feed cylinder to catch the material, which is deposited over the part-build cylinder. Then, the sintering laser draws the layer given from the file, providing it the thickness. After that, the part-build cylinder goes down and the process is repeated. The model is stored in the chamber with loose particles, which are removed after finish the part. It does not require post curing, except if the raw material is a ceramic, which must be fired to improve strength.

The materials used in this technology can be diverse. There are polymers, like ABS, PVC, nylon, polyester, polystyrene, as well as epoxy, wax, metals, and ceramics with appropriate binders. The most common material group used are the polymers, due to the lasers used are cheaper, smaller and easier to use it. With ceramics and metals, it is usual to sinter only the polymer previously mixture with those metallic or ceramic powders. The model created can be sintered in a furnace and infiltrated with another metal if necessary. The maximum dimensions for a model designed are 0.7 m x 0.38 m x 0.58 m.



Figura 4. SLS process (Kalpakjian, S., & Schmid, S. R., 2014)

Applications:

- Electronic housing
- Mounts
- Custom consumer products
- Aerospace hardware

#### 5.2.4.BINDER JETTING (3DP)

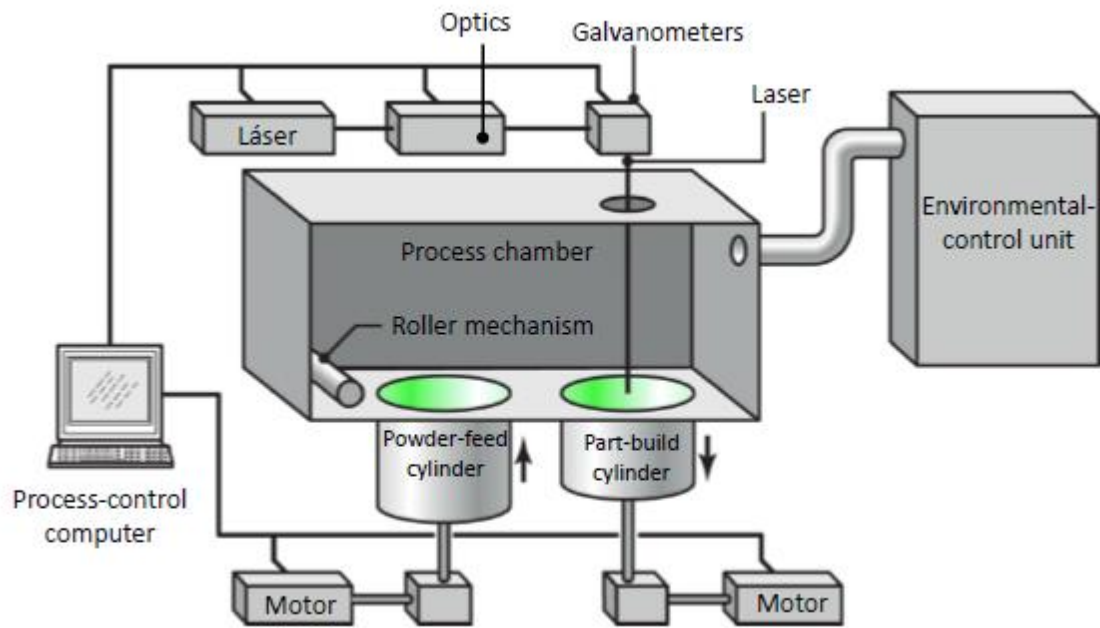
Also known as 3DP, the printhead pours an inorganic binder material onto a layer of ceramic, or metallic powder. Then, the piston, which supports the powder bed, goes down to be deposited over it a layer, which is fused by the binder.

This technology provides an important flexibility in the raw materials as well as in the binders used. The materials used are blends of polymers and fibers, foundry sand and metals. In only one machine, it can be used various binder printheads, and to produce colorful models because of different color-binders.

The parts created by 3DP are rather porous, what gives rise to have not enough strength. Those parts made of metal can be combined with sintering and metal infiltration to produce fully parts, where the part is producing like in a normal process, but the build sequence follows a sintering to burn off the binder and partially fused the metal powders. Metals used are stainless steel, aluminum, and titanium. Inside them, can be put copper or bronze to improve wear resistance and conductivity. The maximum dimensions for a model designed are 4 m x 2 m x 1 m.



Figura 5. Binder jetting process (Kalpakjian, S., & Schmid, S. R., 2014)

Applications:

- Full color prototypes
- Manufacturing tools
- End-use industrial components

### 5.2.5. MULTIJET/POLYJET MODELLING (MJM)

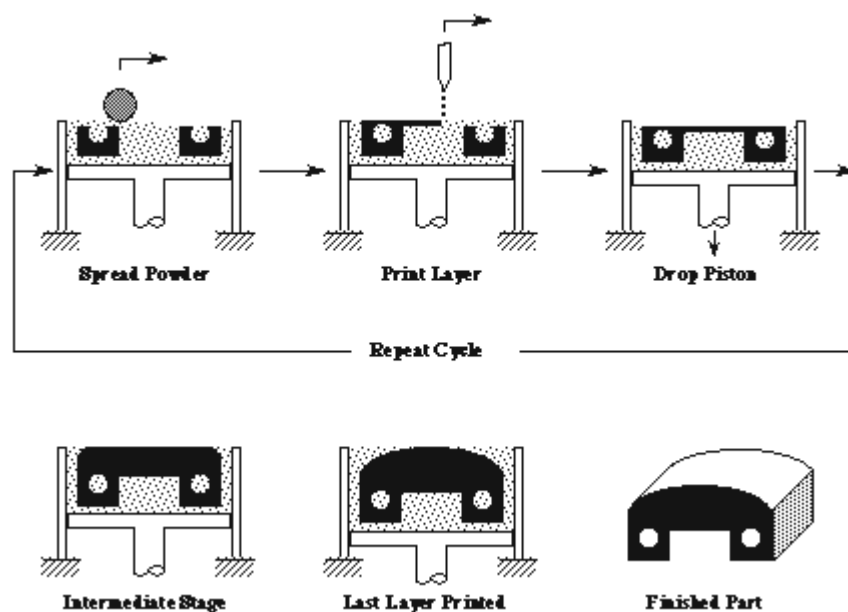
Shortened as MJM, this technology can be compared with inkjet printing of documents. Print heads deposit the photopolymer on the build tray. Ultraviolet bulbs cure and make each layer harder, to avoid curing after modeling, unlike stereolithography. The layers are 16  $\mu\text{m}$  thick, so after finish the process, the model can be handled immediately. The support is a gel-like resin, which is removed from the model through an aqueous solution.

The maximum sizes of a model created by this technology are 500 x 400 x 200 mm. The resins and the abilities are comparable to those used in stereolithography. The main features compared to STL are avoiding part cleanup, avoiding lengthy postprocess curing operations, as well as a higher number of thin layers produced, which allow a better resolution of the model.



Figura 6. Figure Polyjet modelling process ([engatech.com/difference-fdm-polyjet-3d-printing](http://engatech.com/difference-fdm-polyjet-3d-printing))

Applications:

- Medical devices
- Complex and multi material prototypes
- Assembled prototypes

#### 5.2.6.LAMINATED OBJECT MANUFACTURING (LOM)

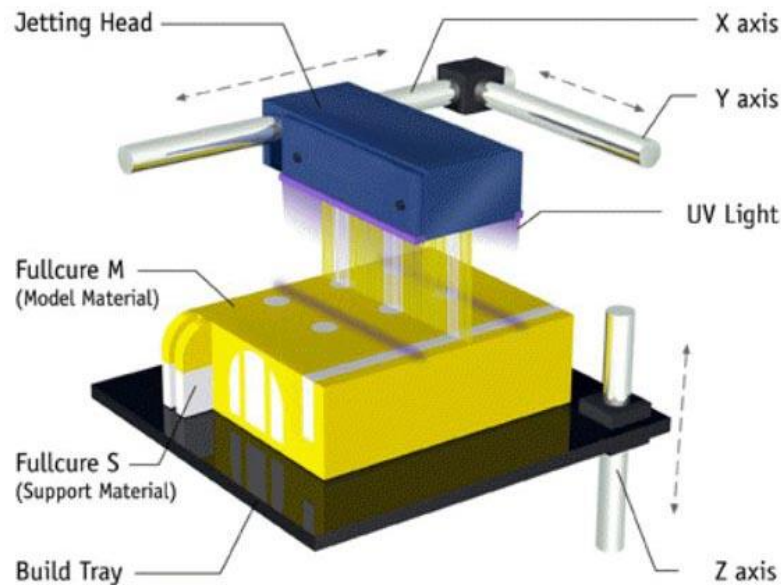
Also known as LOM, it implies a laying down of layers, that are bonded adhesively to one another. The cheapest LOM technology use control software and vinyl cutters are CNC machines, which cut shapes from vinyl or paper sheets. The sheet has several layers and registration holes, which allow alignment and placement onto a build fixture.

This technology is very economical, between 1300 and 2200 \$, and it can use layers of plastic with a heat-activated glue to produce parts. The shapes are burned into the sheet with a laser,



and the parts built layer by layer. When the model is finished, the support material is removed programming the laser to burn perforations in crisscrossed patterns.



Figura 7. LOM process (Kalpakjian, S., & Schmid, S. R., 2014)

Applications:

- Investment casting patterns
- Concept verification
- Direct manufacturing

### 5.3. MATERIALS USED IN ADDITIVE MANUFACTURING

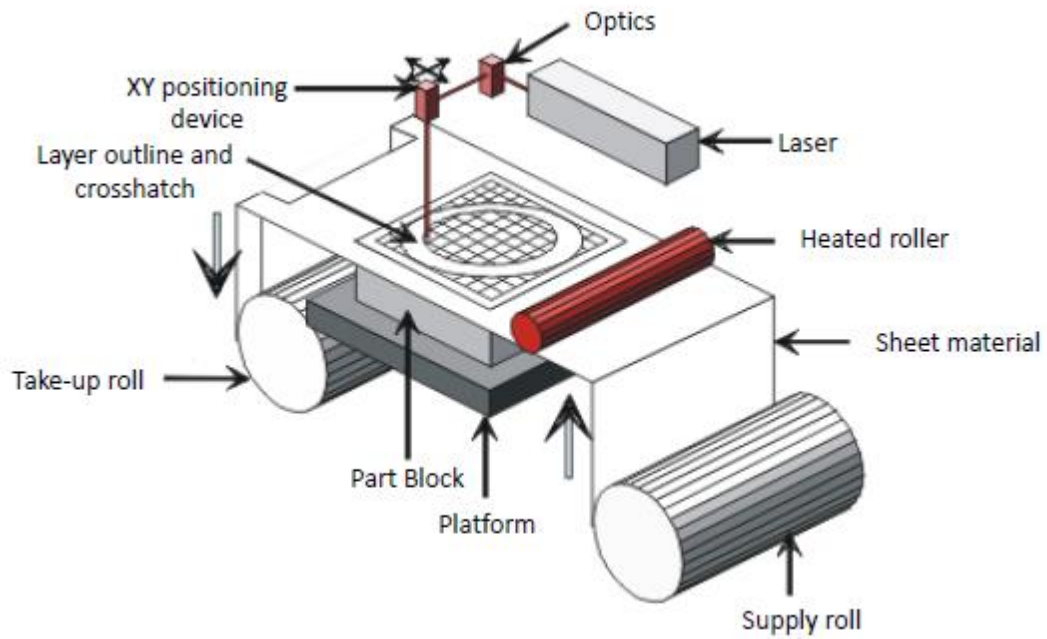
There are a wide range of materials used in additive manufacturing. These are disposed in different forms, such as powder, filament, pellets, granules or resin.

#### 5.3.1. THERMOPLASTIC <sup>[2][3]</sup>

Most of the raw materials used in FDM are thermoplastic. These are colorful, but the qualities between them are different.

##### **Polylactic acid**

Shortened as PLA, comes from sugarcane or tapioca crops. It is bio-degradable, available in a wide range of hardness, and colors. It is disposed in resin for SLA and in filament for FDM. It can be printed through a print bed covered with painter's tape, without a heated build plate. The melting point is between 160 and 180 degrees Celsius. In the different printers, which use PLA as raw material, they have a small fan at the extruder to cool the material at the same time a layer is set up, avoiding to reheat the filament to melt again the raw material. Even though PLA is more brittle than other thermoplastics, in the recent years, the strength has increased in a considerable way, rising its flexibility or reducing the amount of carbon. It is more brittle than ABS and less flexible than nylon. It is sold in filaments, with a diameter of 1.75 mm, and it costs around 19.19 \$/kg <sup>[4]</sup>

##### **Acrylonitrile butadiene styrene**

Shortened as ABS, it is very common for the use in injection molding processes. Like PLA, it is colorful, but is stronger. It is frequent to be seen in FDM, in filament form, which can be controlled during printing. ABS melts between 220 and 225 degrees Celsius, the friction between the material and the extruder is low, and it can be printed onto a thin layer of ABS cement. In diameters of 3 mm, it costs 18.96 \$/kg. <sup>[4]</sup>

##### **Polycarbonate**

Shortened as PC, is a new material for these technologies. It has a high strength and durability, but the temperature to extrude and print is at least 260 degrees Celsius, and most of the printers cannot stand those temperatures. Polycarbonate layers generate microscopic voids between them, which implies a lower strength than objects manufactured through traditional ways. A long time exposed to ultraviolet light causes a more fragility and opacity. They are able to buy with diameters of 1.75 and 3 mm, and it costs 85.19 \$/kg. <sup>[4]</sup>

### **Polyvinyl alcohol**

Shortened as PVA, is very useful for water-soluble supports, which can be removed easily after the manufacturing. It is an adhesive material, biodegradable like PLA, which is extruded from a nozzle between 180 and 200 degrees Celsius. An application of this material in 3D-printing is to manufacture electrical circuits into fabricated objects. Because of its solubility, it must be avoided from wet environments. It is used commonly to support for other thermoplastics. It can be bought in diameters of 1.75 and 3 mm, and it costs from 88 \$/kg. [4]

### **Polyamide**

Commonly nylon, used in filament form for FDM, and powder for SLS. This material is used for objects which require flexibility and strong self-bonding between layers. It is extruded between 240 and 270 degrees Celsius, and has an excellent adhesion between layers. Unlike ABS and PLA, it is resistant to acetone and it cannot be dissolved by that compound. Originally it is white, but the color can be change before or after the printing. It costs 36 \$/kg. [4]

### **High-impact polystyrene**

HIPS, like PVA, is another soluble support material. It is a variation of styrene and it has similar properties than ABS, but it can be dissolved in limonene, a solvent derived from citrus plants, like the acetone with ABS.

### **5.3.2. METALS [2][5]**

The use of metal in 3D printing is not common. However, in the recent years there are more metals compatible with 3D printing, in powder form. Most common metals used in 3D printing are steel, titanium and cobalt. The stainless steel is used in SLS. Metals are used to print in the field of the automotive and the aerospace industry, because of its high strength and its high melting temperatures avoid a good integration between layers correctly.

There are three types of additive manufacturing processes using metals as raw material: powder bed, powder feed and wire feed systems.

Powder bed systems are as well as SLS, as it is shown in figure 8.



Figura 8. Powder bed system (Frazier, W. E., 2014)

On the other hand, in powder feed systems, the powder is conveyed through a nozzle onto the build surface. The laser is used to melt a monolayer or more than one powder layer into the shape desired. After that, it is repeated until the model is finished. There are two types of systems: in the first one, the workpiece remains stationary, and the nozzle is moved, while in the second one, the workpiece is moved, and the nozzle remains stationary. This system, shown in figure 9, has a larger build volume and it is used to restore worn or damaged components.

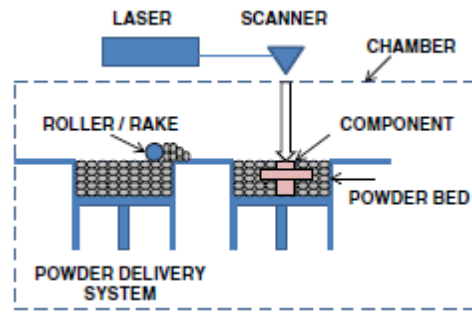

Figura 9. Powder feed system (Frazier, W. E., 2014)

In wire feed systems, shown in Figure 10, the raw material shape is wire, which is deposited upon subsequent passes until the model is done. It is useful for a high deposition rate processing, and for large volumes, but it has the problem that the final workpiece requires more extensive finishing processes, like machining, than the methods of powder bed and powder feed.

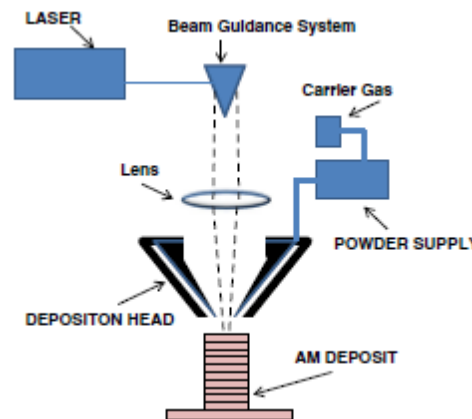

Figura 10. Wire feed system (Frazier, W. E., 2014)

### 5.3.3. CONCRETE <sup>[6]</sup>

Concrete is relatively new in 3D printing, and it is used mainly for the construction of buildings or structures. Like FDM technology, it is extruded through a nozzle in layers (Figure 11), without the use of formwork or any subsequent vibration. Although the process is like FDM, they do not use FDM printers. The main problem to print it, is that the reinforcement as such cannot be printed. Mentioned before, steel is disposed in powder for printing and it uses SLS. An alternative could be to use what it knows as fiber-reinforced concrete.

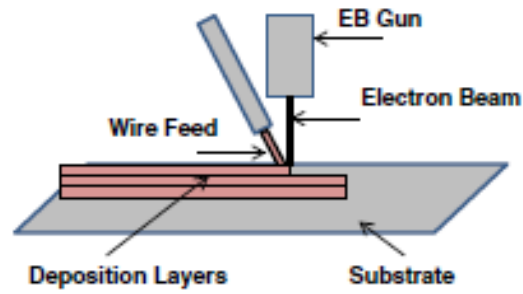

Figura 11. Process of printing concrete layers (Le, T. T., Austin, S. A., Lim, S., Buswell, R. A., Gibb, A. G., & Thorpe, T., 2012)

Fiber Reinforced Concrete [7] can be defined as a composite material consisting of mixtures of cement, mortar or concrete and discontinuous, discrete, uniformly dispersed suitable fibers. There are different types of fibres, but the most common are:

- Plastic
- Steel
- Glass

Plastic fibers are commonly made of Polypropylene (PP), a thermoplastic partially crystalline. This type of thermoplastic is characterized as it has partially ordered structure, a milky aspect, greater intermolecular forces and resistance to fracture, but a low resistance to temperature (it melts between 160 and 165°C). For this material, there are two types of fibers: microfibers and macrofibers.

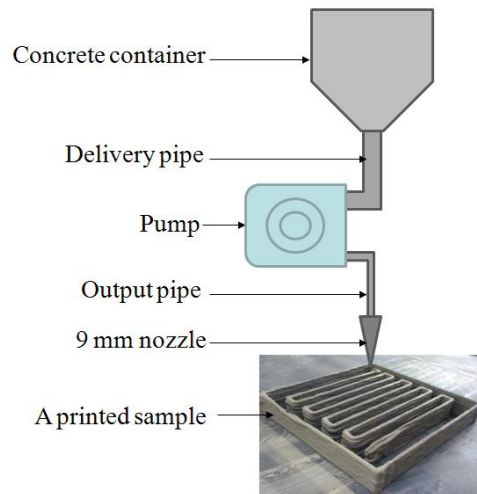
Microfibers (Figure 12) have a length between 5 and 20 mm and a diameter between 0.02 and 0.2 mm. It is used mainly in rough concrete, top concrete layer (germ.: Aufbeton), concrete floor and walls. It can be placed with fresh concrete, which influences on the drying time. Also, it plays a role in the concrete consistence, and in the density. Microfibers rise the strength against fire and against hits or collisions as well as a reduction of wear, and improves the dew and frost behavior. A common dosage is about 0.9 kg/m<sup>3</sup>.



Figura 12. Polypropylene microfibers

Macrofibers (Figure 13) have a length between 30 and 65 mm, and a diameter between 0.4 and 1.2 mm. They improve the mechanical properties of the concrete, and they form a corrugated surface, which improves the transmission loads between concrete and fibers. In some constructions, they replace totally the reinforce concrete, especially in watertight

constructions and with aggressive environment, because of the water gives rise to corrosion of the steel reinforcement.



Figura 13. Polypropylene macrofibres

Steel fibers are introduced through mix operations in concrete. They are introduced and compressed into the formwork with the concrete. The composite material of steel fibers and concrete looks almost uniformly (Figure 14), according to the manufacturing.

Steel fibers concrete components are calculated with the development of the spot of rust (oxidation rate), if that is not impregnated or fibers of rustproof steel have been used. A steel fiber weakening by corrosion and with that an interference of its favorable effect is against it at most in the carbonatation area, in areas with inadmissible high content of chloride or with possible wide cracks, with available moisture for the corrosion is necessary.

The ultimate tensile strength is between 800 and 2000 MPa, but in most of the cases, is approximately 1000 MPa.

There are some quality differences between Steel fibers reinforced concrete and reinforced concrete:

- The fiber diameter is small (generally 1 mm or lower)
- The fiber length is smaller regarding the construction size (3-6 cm)
- The fibers are distributed over the same construction
- They are not disposed, but they are placed in any construction
- Not all the fibers contribute to force distribution





Figura 14. Steel fiber-reinforced concrete cross section

Glass fibers show solid characteristic as well as fluency. It responds to a fragile break, according to Hooke's law, and it shows a totally elastic behavior without fluency area. Its mechanical behavior is like a solid body. The physical behavior can be described as solid material, after the cooling process, which reaches a high viscosity.

The strength is variable, for only one fiber it reaches 3500 MPa, but in extreme cases, may be lower than 500 MPa. The fibers have a elastic strain behavior, and the fragil break is between 2 and 5% of the strain. Its Young modulus is 72000 MPa, and its shear modulus is between 15 and 36 GPa, with a shear contraction between 0.13 and 0.32, regardless of temperature.

The main problem with the glass fibers is the compatibility with the hydrated cement (germ.: Zementstein), which is alkaline. Conventional building glass, A-Glas (germ.: Natronkalk-Glas) or E-Glas (germ.: Borosilikatglas), are instable if they are compared with alkaline solutions. On the upper area of the glass arises scratch corrosion, which conducts through stress concentration (germ.: Kerbwirkug) to lose the strength and to have a more embrittlement.

There are two types of glass fibers: Alkaline resistent and not alkaline resistant fibres.

The alkaline resistant fibers are manufactured from melting glass through drawing or by injection blow. With that process, it should enable the fibers treatment. At the same time, the coating upper surface creates a useful protection against the cement attack. These fibers are coiled like fiber bundels subsequent to form a coil, previously to cut the short fibers. These can be, because of the properties, integral or easily water dispersible. Integral fibers (Figure



15) are from 6 to 24 mm long cut and in loose packing. In water dispersible fibers (Figure 16), these are soluble in water when both are in contact and therefore are effective in concrete. Like integral fibers, these are cut in a length between 6 and 24 mm, but with the difference there are not any bundle fibers, but single fibers in the concrete matrix. Because of that, it is ensured a considerable distribution of the single fibers.



Figura 15. Integral glass fibers (Wietek, B., 2014)



Figura 16. Water dispersible glass fibers (Wietek, B., 2014)

In small dosage amounts, alkaline fibers improve and change the distribution properties of the fresh concrete and the serviceability properties of the stiffening and hardened concrete.

In fresh concrete, glass fibers ensure a significant matrix cohesion and in hardened concrete prevent from creation of microcracks in the structure. The prevention of cracks in young concrete (germ.: junger Beton) as a result of different use can be obtained.

The smallest thickness of a construction with glass fibers can be reduced to a few millimeters. Because of that, it can be manufactured delicate shapes.

Regarding the not alkaline resistant fibers, they are soluble in contact with fresh concrete, and they lose their strength. As consequence, the fibers are effective for a while, or really like a strengthening in the concrete. Positive mechanic influences of these products are brittle over the building parts, the fresh concrete does not show any enough strength.

#### 5.4. GENERAL 3D PRINTING APPLICATIONS

The earliest application of 3D printing [8] was to create prototypes before the final manufacturing of the product. This application is called rapid prototyping. For that, in first place, through previous researches, the design is determined before creating the 3D model. Then, a conceptual design is created, which is based on the functionality and the handling. All the elements of a final product are manufactured separately. Finally, these elements are assembled to check if there is a correct fit and function. Figure 17 shows this process.



Figura 17. Rapid prototyping process (Kalpakjian, S., & Schmid, S. R., 2014)

Commonly the prototypes do not need the material strength of the commercial object, so it is used plastic or resin material to test the prototype before to continue with the mass

production. An exemplary rapid prototyping application is the manufacturing of jewels, where the jewelers test the design in wax or biodegradable plastics, and manufacture in gold or silver not before the client has approved the prototype fit. Figure 18 shows another example of a rapid prototyping process for dentures.



Figura 18. Steps to manufacture orthodontic aligners through rapid prototyping (Kalpakjian, S., & Schmid, S. R., 2014)

In the cases of metal-fabrication systems, 3D printing is used to create final products and design, instead of only prototypes. Things are serial numbers or joined structures can be put in the physical structure of the product without tooling steps after the printing. This application is known as Direct Digital Manufacturing, which allows updates during a production cycle without retooling the production line, that is, after updating the 3D modified

model to the printer, it changes automatically. General Electric has been started to use this application to the construction of its future aircraft jet engines, to save time overall in the production of high-precision engine components, assembling and printing them at the same time without traditional joining processes as welding or brazing.

Another good application is to improve objects to fulfill a function previously fulfilled but with better characteristics, and to bring it to life items out of stock, because of they have passed the lifecycle. In other words, it can be used to repair or restore objects. The main advantage, is the avoidance to store spare part. It is enough to download the updated file and print the spare when it is required.

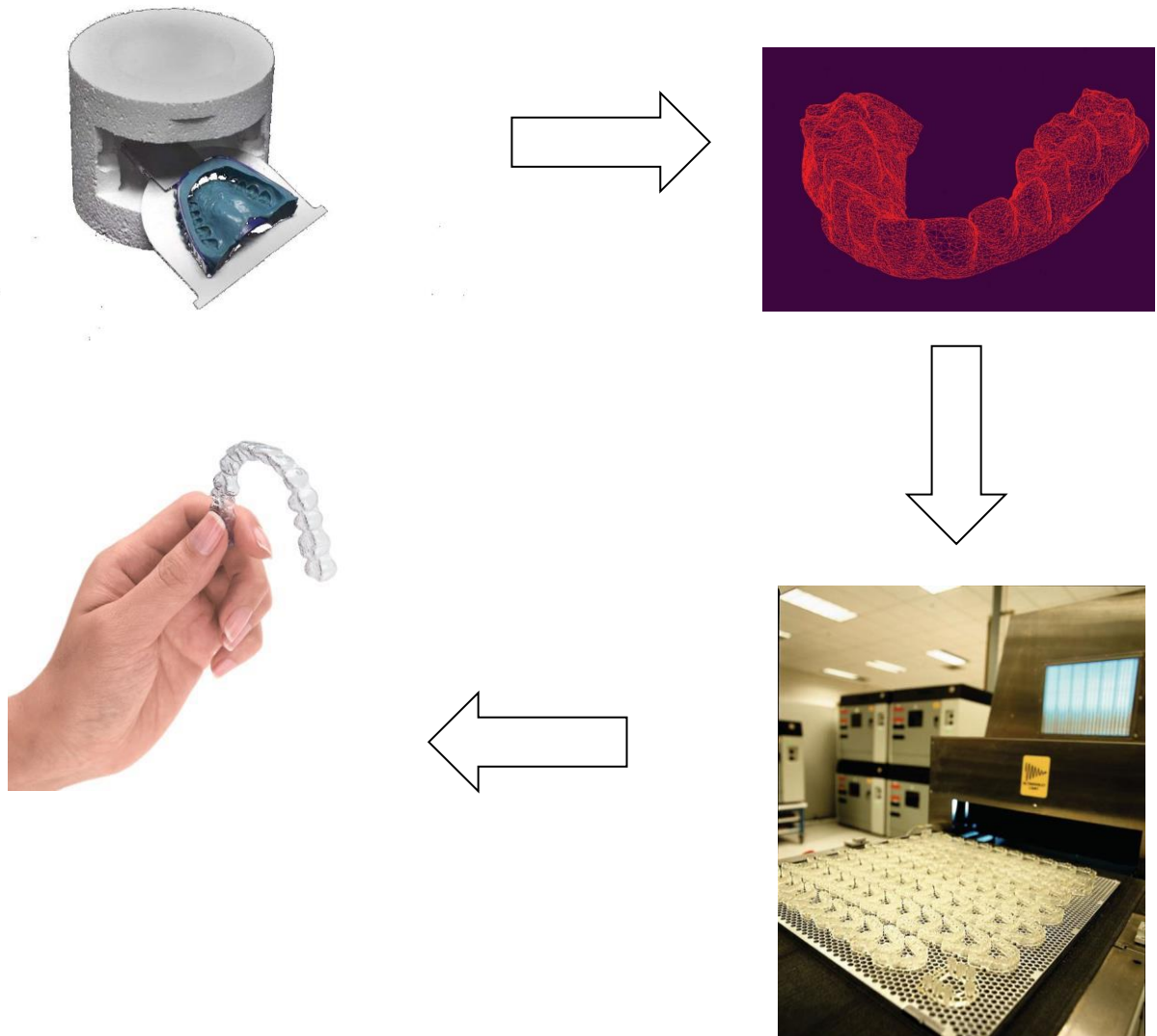
In real life, one of the most known applications is to customize our own things. This application cover the range from normal objects, such as iPhone covers or simple cups, to biological prosthetics. In this last case, it old photographs are used or the modelling is based on remaining body elements, which makes to recover basic functions of the life, lost or unable to do after an injuring or replace a new component with higher precision. In 3D bioprinters, collagen, living cells and tissues are used to obtain organs, or parts of the body. Also, external prosthesis to replace lost limbs can be created through 3D printing. For that, the remaining limb is scanned, and then it is mirrored. Figure 18 shows an example of external prosthesis.



Figura 19. External prosthesis of a leg created through 3D printing (Hausman, K. K., & Horne, R., 2014)

In recent years, artists have developed new 3D printing materials as artificial leather and flexible lattices, which can be worn in personal clothing or footwear fitted to the customer. An example of that, is a stunning 3D-printable gown custom-fitted to the specific proportions of fashion model Dita von Teese (Figure 19) created by the designer Michael Schmidt and the architect Francis Bitonti, through a curved latticework design based on Fibonacci

sequence, and applying the scan on the model's body allowed the creation of a 3D-printed mesh complete with interlocking flexible joints that wraps her perfectly.



Figura 20. 3D-printed gown worn by Dita von Teese (Hausman, K. K., & Horne, R., 2014)

3D printing has application in the field of the architecture. Columns are built through 3D printing with concrete as material. For the construction, is not used the formwork (see chapter 3), and after printing a concrete layer, a reinforcement layer is added. Reinforcement layer can be made of steel or carbon. This process is repeated several times until finishing the construction. Figure 21 shows a column built through 3D printing.



Figura 21. Column built through 3D printing with steel reinforcement

Local Motors have developed the first car manufactured through 3D printing <sup>[9]</sup>, as Figure 22 shows. For that, they have used DDM<sup>D</sup> and carbon fiber reinforced ABS plastic. The car weighs 1800 lb (816.47 kg) and the printing costs were around 1243 €. The printing process took about 44 hours to print the car in one piece. Then, a machining process, milling, was applied to fulfill with the tolerances, which took one day. As the printing vehicle was only for the structure, components such as motor, battery, tyres, wheels or power trains were assembled to the car after finishing process. This part took less than one day.



Figura 22. 3D printed car by Local Motors using carbon fibers (launchforth.io)

---

<sup>D</sup> Direct Digital Manufacturing



### 3. 3D PRINTING IN CIVIL ENGINEERING

#### 3.1. SPECIFICATIONS FOR CIVIL STRUCTURES [10]

One of the newest field application of 3D printing is in civil engineering. In the field of the construction, there are several challenges, which have to be overcome through these technologies:

- Low labor efficiency
- High accident rate
- Low quality work
- Difficulty to apply control on construction site

The first researches aimed to a group of different 3D printing technologies called Freeform Construction, which the printer creates large-scale components without the need of formwork, as explained in chapter 2. The cost could be lower, and there would be freedom to choose the geometry, whose performance would be more accurate than the traditional ways.

One of the Freeform Construction methods is the Contour Crafting, used in building houses. Figure 23 shows how it works, similarly to FDM, where a nozzle is supported by a gantry system, which moves in two parallel lanes. This nozzle has 6 axis positioning, can extrude both sides and filler material. It is useful to place reinforcement before pouring concrete, plastering and tiling, or plumbing and installing electrical modules.



Figura 23. Contour Crafting process (Yossef, M., & Chen, A., 2015)

However, this method has several challenges. It is necessary to follow various steps, such as molding, installing reinforcement, and placing concrete to build layers 20 mm of height maximum. The mold becomes a part of the wall. Because of the mentioned disadvantages, another Freeform Construction method, called Concrete Printing, was developed to fix those problems. The printer has a frame of 5.4m x 4.4m (footprint) x 5.4m (height) and a printing head. The nozzle is supported at the head to provide the material extrusion. Due to experimental tests, the best mix of a high performance for printing concrete, is the fiber-reinforced fine-aggregate concrete.

This year, the Massachusetts Institute of Technology <sup>[11]</sup> have created a robotic system that can build the basic structure of a building in less than 14 hours. The machine is a vehicle with a large industrial robotic arm incorporated for reach and a smaller arm for dexterity. In this small arm, different tools can be attached, like a welding system or spray head that throws different building materials like foam. This system is known as Digital Construction Platform (DCM) (Figure 24), which is intended to be autonomous, but because of safety reasons, it needs supervision and checking. The energy sources are electricity or solar panels. Figure 25 shows a prototype building this system.

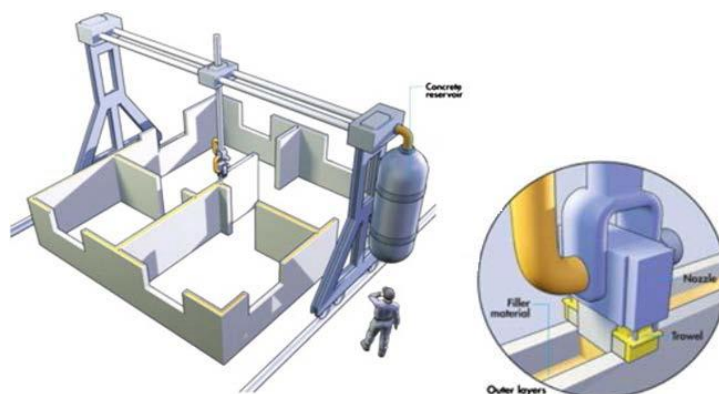

Figura 24. Digital Construction Platform ([money.cnn.com/2017/05/02/technology/3d-printed-building-mit/](http://money.cnn.com/2017/05/02/technology/3d-printed-building-mit/))



Figura 25. Prototype created by DCM, it is a dome 50 feet in diameter and 12 feet high ([money.cnn.com/2017/05/02/technology/3d-printed-building-mit/](http://money.cnn.com/2017/05/02/technology/3d-printed-building-mit/))



### 3.2. CIVIL ENGINEERING APPLICATIONS <sup>[10]</sup>

Currently, the 3D printing applications in civil engineering are reduced to build houses and bridges. Printed houses often consist of parts assembled to form a whole structure. However, Freeform Construction only consider the structure, not additional parts, like electric facility, or plumbing. A good example comes from a Chinese company called WinSun, who printed whole apartment blocks. The company affirmed that the houses fulfilled with the requirements of the main national standards, and thus, passed one of the main goals for 3D printing houses.

Another example of houses built by 3D printing, occurred in Dubai <sup>[12]</sup>. The construction of the building seen at Figure 26 was carried out by WinSun as well. The materials used were Special Reinforced Concrete, Fiber Reinforced Plastic and Glass Fiber Reinforced Gypsum. The construction time took a couple of weeks, the labor cost was reduced by 50-80% and the waste between 30-60%.



Figura 26. Building constructed by 3D printing in Dubai (3dprint.com)

Another application in the field of civil engineering is in the construction of non-conventional structures. E.g. a Dutch company for architecture called DUS used a technology to create walls with integrated solar panels, where the angle of the solar panel could be optimized automatically for any location, avoiding to manufacture a mold for every angle.

Regarding the design of 3D printable bridges, Spain is the pioneer country in the world <sup>[13]</sup>. A research team from the Institute of Advance Architecture of Catalonia (IAAC), has created a bridge (Figure 27) using layers of concrete powder micro-reinforced with thermoplastic polypropylene.



Figura 27. Bridge built through 3D printing in Spain (dailymail.co.uk)

## 4. APPLICATIONS IN HYDRAULIC ENGINEERING

### 4.1. INTRODUCTION

In the following chapters 4.2 and 4.3 commonly known and widely used structures out of the field of hydraulic engineering are presented. Both the types and construction methods are discussed and furthermore typically fields of application are highlighted. Chapter 4.4 talks about the modeling aspects of such hydraulic structures. Finally, in chapter 4.5 the feasibility and viability of the 3D printing technologies before mentioned for applications in hydraulic engineering are discussed. Due to the fact, that there is not enough research about such applications at this time, here mainly the personal opinion is given.

### 4.2. DAMS [14]

Dams are built in wide valleys. They act as a barrier for water and therefore create large water storage reservoirs. Hydropower is often used in conjunction with dams to generate electricity. The basic goals to build a dam, is to provide a safe retention and storage of water, as well as, to produce hydroelectric energy. Additionally, dams with their storage reservoirs increase safety against flooding in case of flood events due to their water retention properties. The consequences occasioned by those goals, are interruption of the flow continuity, changes of the ground water proportion, changes of the landscapes, and in cities because of secondary applications like tourism.

There are two types of dams. On the one hand, embankment dams are built through earthfill or rockfill. The face slopes have a moderate angle, as upstream as downstream, providing a wide section and a high construction volume relative to height. On the other hand, there are concrete dams, which are constructed with mass concrete. The faces slopes have steep downstream and near vertical upstream, and they have relatively slender profiles.

Embankment dams are the most common type of dams, because of technical and economic reasons. Approximately 85-90% of the dams built are of this type. Table 2 shows the number of large dams belonging to both types. Available and untreated materials are used, which involves an increment of the adaptability in a wide range of circumstances, unlike concrete dams, which need a special attention about the foundation conditions.

| Group                   | Type          | ICOLD code | %    |
|-------------------------|---------------|------------|------|
| <b>Embankment dams</b>  | Earthfill     | TE         | 82.9 |
|                         | Rockfill      | ER         |      |
| <b>Concrete dams</b>    | Gravity       | PG         | 11.3 |
|                         | Arch          | VA         | 4.4  |
|                         | Buttress      | CB         | 1    |
|                         | Multiple arch | MV         | 0.4  |
| <b>Total large dams</b> |               | 41413      | 100  |

Table 2. Large dams classification according to ICOLD (1998) (Novak, P., Moffat, A. I. B., Nalluri, C., & Narayanan, R., 2007)

It can be defined as a dam built from natural materials by means of excavations or obtained by enclosure. Natural materials are placed and compacted without any binding agent, by means of high-capacity mechanical plant. The construction process depends on the weather and soil conditions, but is continuous and highly mechanized. [15]

As mentioned before, there are two types of embankment dams.

Earthfill embankment dams have at least compacted soils filling the 50% of the placed volume material. It is constructed primarily of selected engineering soils compacted uniformly and intensively in relatively thin layers and at a controlled moisture content. Figures 28 and 29 show different types of earthfill embankment dams.



Figura 28. Homogeneous dams (Strobl, T., & Zunic, F., 2006)

Characteristics of homogeneous dams:

- The whole dam consists of a uniform, little permeable pouring material approaching.
- The seepage line is raised above the ground.

- The gradient of embankment is 1 in vertical projection and between 1.5 and 3.5 in horizontal projection.
- They are economic until a height of 20 m.
- They come generally to the application at a temporary one ponding.
- The dam structure is streamed through during the ponding the base must be protected in the area of likely water outlet, especially in the airside of the gradient of embankment.



Figura 29. Zoned dam (Strobl, T., & Zunic, F., 2006)

Characteristics of zoned dams:

- The cross section differences the shoulder and the core seals.
- Filter stable transition or drainage zones must be arranged between shoulder and core.
- The core filling and shoulder are carried out at the same time.
- To build big dams is possible in economic terms
- A natural nuclear material must be able for crowd and tightness with enough nearby
- The construction is unsusceptible against settlement of the subsoil
- The subsoil is subjected to a so small hydraulic gradient
- The allow hydraulic gradient in earth's core is generally  $i \leq 5$

Rockfill dams contain a sealing element <sup>[15]</sup>, which can be made of natural raw material or coming from the concrete or the asphalt. At least 50% the rest of the dams exist from stones or gravel with an interval grain diameter between 2 and 600 mm. Figures 30 and 31 show different types of rockfill embankment dams.

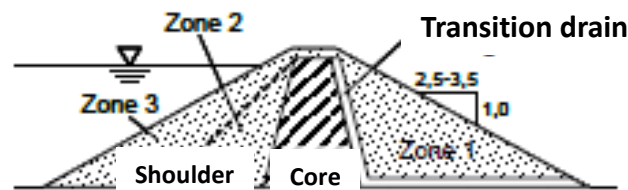

Figura 30. Rolled clay core dams (Strobl, T., & Zunic, F., 2006)

Central rolled clay core dams need to prepare the material, because of the core materials are not dense enough. An alternative could be to build a wall slot made of clay concrete in the core.

In the inclined rolled core dams, there is air sided in body supporting, and it is possible to add sensitive debris materials in the body supporting. However, The core is subjected to shear stress.

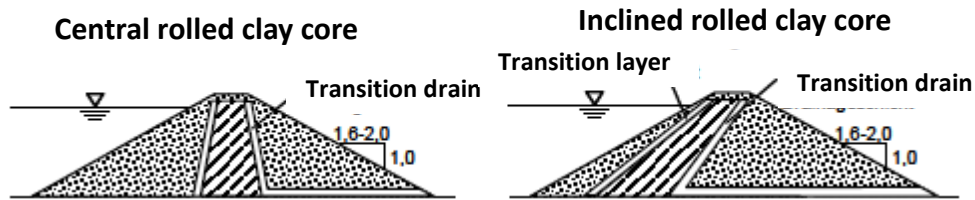

Figura 31. Asphaltic membrane dams (Strobl, T., & Zunic, F., 2006)

Upstream asphaltic membrane dams are able to install in the shoulder sensitive water debris materials, a valid heading of the water pressure, a possible water level reduction, a temporal separation of the seal installation and dam fill (germ.: Damschüttung), a good accessibility of the seal surface through reparations, and a reduction of the landscapes.

Central asphaltic membrane dams have the smallest possible seal surface, the minimum length joint to the subsoil, a valid mechanic use during filling (germ.: schüttung) and in working, seals are protected against external influences, a good seal control through drain zone, a possible ponding on both sides, and the consideration of the joint to the seal subsoil as an important construction element.

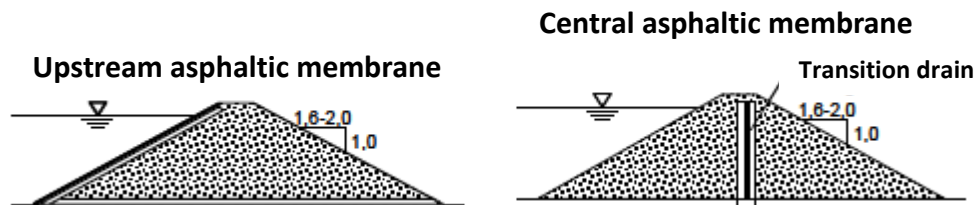

Figura 32. CFRD dam (Strobl, T., & Zunic, F., 2006)

In Figure 32 CFRD is shown according to Strobl [15]. The labels refer to following parts of the construction:

- 1A: fine and medium sand (no cohesion)
- 1B: sand with parts of silt
- 2A: fine gravel
- 2B: gravel with fine parts
- 3A: small stones chosen, same layer thickness than Zone 2
- 3B: any bulk material, 0.8-1 m layer thickness
- 3C: any bulk material, 1.6-2 m layer thickness
- 4: downstream embankment settlement (germ.: luftseitiger Boschungsabschluss)

Concrete Faced Rockfill Dam, also known as CFRD, is a type of rockfill embankment dam, which uses reinforced or asphaltic concrete in the upstream face or deck. It is used for very large dams in South America and Australia, as it shows table 3. Deck thickness generally increases with depth below crest level, but the concrete deck must be subdivided into rectangular strips running normal to the dam axis, or into rectangular panels, to accommodate deformation of the rockfill. This requires an expensive and sometimes troublesome joint detail incorporating a waterstop.

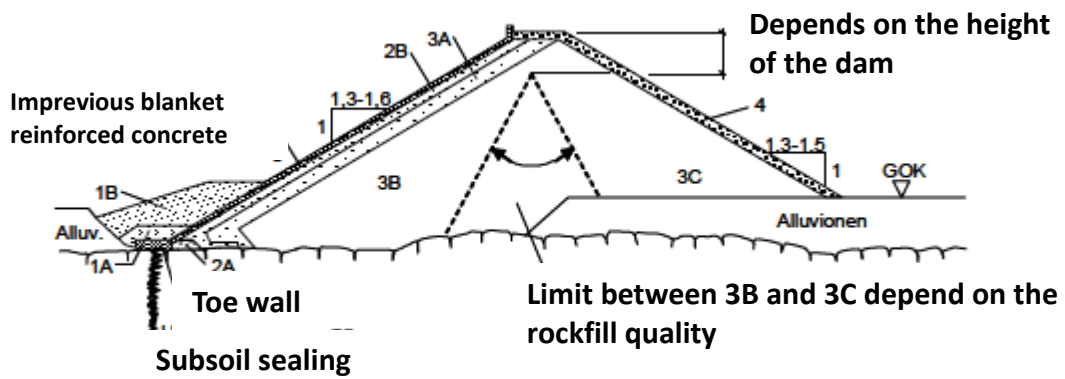
These are the construction principles of the CFRD:

- Supporting body: rockfilling

- Seal system: reinforced or asphaltic concrete in the upstream face
- Joint to the subsoil: toe wall (germ.: Herdmauer)

| NAME           | CONTRY   | HEIGHT | REMARK  |
|----------------|----------|--------|---|
| Aguamilpa      | Mexico   | 187 m  | Highest CFRD in the world   |
| Tiangshengqiao | China    | 180 m  | Highest rockfill dam in Asia                                      |
| Foz de Areia   | Brazil   | 160 m  | Highest CFRD in 1981  |
| Messochora     | Greece   | 150 m  | Highest dam in Europe   |
| Xingo          | China    | 150 m  | Shell manufactured with slip<br>(germ.: Sockel mit Gleitschalung) |
| Salvajina      | Brazil   | 148 m  | Highest gravelfill dam  |
| Segredo        | Colombia | 145 m  | Slope 1:1.3   |
| Mohale         | Lesotho  | 145 m  | Highest dam in Africa   |
| Alto Anchicaya | Colombia | 140 m  | Highest dam in 1974   |

Table 3. Largest dams in all over the world (Strobl, T., & Zunic, F., 2006)

#### 4.3. FLUID MACHINERY <sup>[16]</sup>

The fluid machinery are mechanical systems designed to allow an energy exchange between a fluid and a rotation shaft. To check the behavior of those machines, it must consider the flow rate and the working pressure, which give the hydraulic power needed, absorbed by the shaft (turbines) or given to it (pumps).

There are several groups to classify the fluid machinery:

- Considering their working principle
- Considering the direction of energy transfer
- Considering the component being modified
- Considering geometric characteristics
- Considering other factors, such as flow or compressibility

Attending to working principle, it is differenced the positive displacement machines from the turbomachines.



Positive displacement machines have a varied contour, which forces the fluid to pass through the machine, because of the changes of volume. These are some of their characteristics:

- Displacement of a confined volume of fluid, compressing or expanding it
- They offer a fluctuating flow rate
- Hardly sensitive to viscosity variations
- They suffer middle flow rates and high pressures
- Flow rate range is tight
- They can be alternative (piston or diaphragm) or rotary machines (gears, blades)

The positive displacement machines applications in civil engineering are so varied:

- Use of cranes and lifts
- Extraction of mining resources (i.e.: crude oil)
- Drive operations, like to drive the turbine blades
- To control the sluice gate of a dam

On the other hand, the turbomachines use the variation of the kinematic moment of the fluid between the inlet and the outlet as the method to transfer energy between the fluid and the rotation shaft. They are used in fluid transport, excepting when the working fluid is so heavy.

These are their characteristics:

- Fluid pass through the rotating element, without any interruption of the flow motion, modifying the fluid momentum
- They are so sensitive to viscosity variations
- They offer high flow rates, and moderate-low pressures
- Flow rate range is wide
- Its geometry can be axial, radial, or a combination of both (mixed)



Figura 33. Examples of positive displacement machines and turbomachines (Pérez, J. G., 2010)

These are some turbomachine applications in civil engineering:

- Pumping systems: supply networks, drain and street control, power stations
- Electricity generation: wind farms (aerogenerators), hydroelectric power plants (hydraulic turbines), thermal power plants (steam and gas turbines)
- Ventilation systems of buildings, tunnels and facilities

Regarding the direction of energy transfer, the fluid machinery is divided into generator and receptor machines.

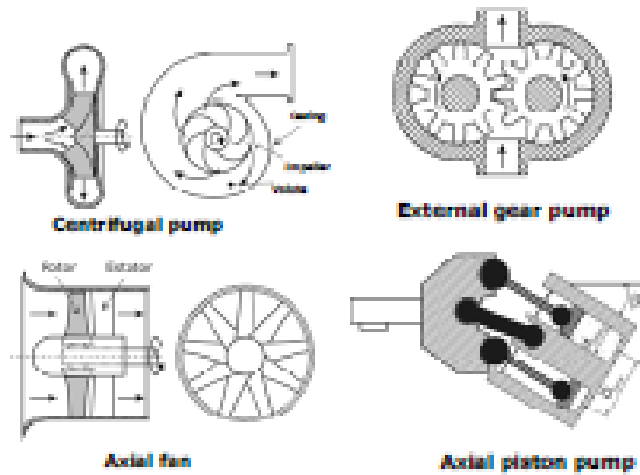
Generator machines increase the fluid energy. Some examples are pumps, fans, compressors or propellers.

Receptor machines extract energy from a fluid. Good examples are hydraulic turbines, aerogenerators or hydraulic engines.



Figura 34. Examples of receptor machines (Pérez, J. G., 2010)

Regarding the turbines, the figure 35 shows the classification of the different types of turbines, according to its application field [17]:

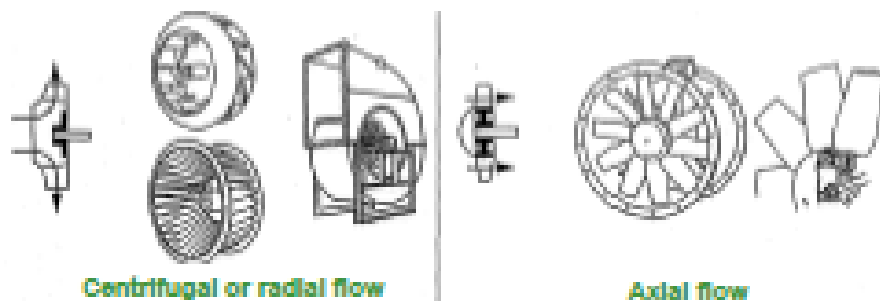

Figura 35. Distribution of the different types of turbines (Minor, H.-E., 2008)

In impulse turbines are included the cross-flow and the Pelton turbine (Figure 36). Because of the head, the available high pressure in the impeller inlet is totally converted in velocity head. The impeller of the turbine goes streaming along. The impeller does not take all the supplied working water, but only a part. These are in Pelton turbines individual impeller cups.

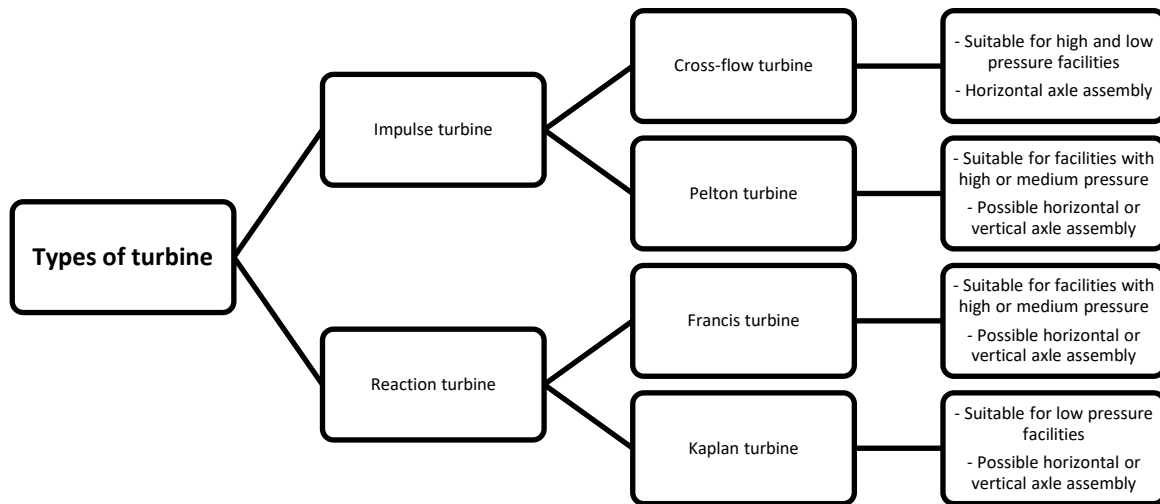

Figura 36. Pelton (left) and cross-flow turbine (Minor, H.-E., 2008)

Regarding the reaction turbines, Francis and Kaplan belong to this group (Figure 37). The impeller is completely flowed around and dipped in submarine water. In the submarine water experiments a counterpressure. The high pressure in the impeller inlet is partially converted in velocity head.

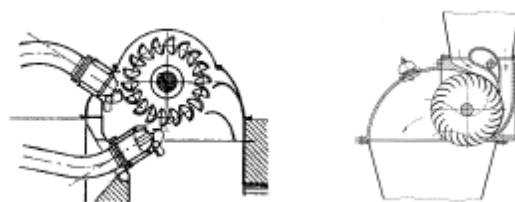

Figura 37. Francis (left) and Kaplan turbine (Minor, H.-E., 2008)

## 4.4. MODELS OF HYDRAULIC STRUCTURES

### 4.4.1. INTRODUCTION

In laboratories, like UIBK labor, scaled models are used to assess the general behavior of phenomes like e.g. flow and sedimentation processes. In chapter 4.4.2 the scaling process is explained, the variables to take into account of the different tests, the origin of the process, and the most important dimensionless numbers.

Along the chapters 4.4.3, 4.4.4, and 4.4.5, the similarity conditions are explained, considering the conditions in terms of lengths, velocities and forces.

Finally, in chapters 4.4.6, and 4.4.7, on the one hand the similarities with the most important dimensionless number and when they are used are explained, and on the other hand the scale effects and how to reduce them are explained as well.

### 4.4.2. SCALED PHYSICAL MODELLING OF HYDRAULIC STRUCTURES

#### (DIMENSIONAL ANALYSIS)

The scaled physical modelling is carried out in a laboratory, considering a specified value and a size. The fundament of the similarity theory forms the dimensionless size and the dimensionless representation of the law of nature. This lack of dimensions is reached through a process called gradation (germ.: Skalierung) <sup>[18]</sup>, which represents the value of the same dimension divided. In fluid mechanics, can define first a scale length  $L$  and a scale speed  $U$ , which corresponds to the dimension of the problem given <sup>[19]</sup>.

| Variable | Characteristic value          | Dimensionless value   |
|----------|-------------------------------|---|
| Length   | Characteristic Length $L_c$   | $x^* = \frac{x}{L_c}; y^* = \frac{y}{L_c}; z^* = \frac{z}{L_c}$   |
| Time     | Characteristic Time $t_c$     | $t^* = \frac{t}{T_c}$   |
| Velocity | Characteristic Velocity $U_c$ | $\vec{v}^* = \frac{\vec{v}}{U_c} = \frac{u}{U_c} \vec{i} + \frac{v}{U_c} \vec{j} + \frac{w}{U_c} \vec{k}$ |

|                |  |  |
|----------------|--|--|
| Density        | Characteristic Density $\rho_c$ ; $\Delta\rho_c$ | $\rho^* = \frac{\rho}{\rho_c}$ ; $\Delta\rho^* = \frac{\Delta\rho}{\Delta\rho_c}$  |
| Pressure       | Characteristic Pressure $\Delta p_c$             | $\Delta p^* = \frac{\Delta p}{\Delta p_c}$   |
| Temperature    | Characteristic Temperature $\Theta_c$            | $\theta^* = \frac{\theta}{\theta_c}$   |
| Nabla Operator | Characteristic Length $L_c$                      | $\nabla^* = \frac{\partial}{\partial x^*} \vec{i} + \frac{\partial}{\partial y^*} \vec{j} + \frac{\partial}{\partial z^*} \vec{k}$<br>$= L_c * \nabla$ |

Table 4. Normalized variables in dimensional analysis

There are two systems, whose dimensionless ratio is the same, and therefore they are physically similar. They are not physically the same, because they difference each other in the scale used. For that, the conservation differential equation, Navier-Stokes equation, is rewritten to convert the order of magnitude of each term as a dimensionless parameter, formed as the ratio between some characteristics:

$$\rho \frac{\partial \vec{v}}{\partial t} + \rho (\vec{v} \cdot \nabla) \vec{v} = \rho \vec{g} - \nabla p + \frac{\mu}{3} \nabla(\nabla \cdot \vec{v}) + \mu \nabla^2 \vec{v}$$

Normalized variables:

$$\rho \vec{g} = \rho_c g_c \rho^* \vec{g}^* \quad \nabla p = \frac{\Delta p_c}{L_c} \nabla^* p^* \quad \mu \nabla(\nabla \cdot \vec{v}) = \frac{\mu_c U_c}{L_c^2} \mu^* \nabla^*(\nabla^* \cdot \vec{v}^*)$$

$$\nabla^2 \vec{v} = \frac{U_c}{L_c^2} \nabla^{*2} \vec{v}^* \quad \frac{\partial \vec{v}}{\partial t} = \frac{U_c}{t_c} \frac{\partial \vec{v}^*}{\partial t^*} \quad (\vec{v} \cdot \nabla) \vec{v} = \frac{U_c^2}{L_c} (\vec{v}^* \cdot \nabla^*) \vec{v}^*$$

Normalization of the Navier-Stokes equation:

$$\left( \frac{L_c}{U_c t_c} \right) \rho^* \frac{\partial \vec{v}^*}{\partial t^*} + \rho^* (\vec{v}^* \cdot \nabla^*) \vec{v}^* = \left( \frac{g L_c}{U_c^2} \right) \vec{g}^* - \left( \frac{\Delta p_c}{\rho_c U_c^2} \right) \nabla^* p^* + \left( \frac{\mu_c}{\rho_c L_c U_c} \right) \left[ \frac{\mu^*}{3} \nabla^*(\nabla^* \cdot \vec{v}^*) + \mu^* \nabla^{*2} \vec{v}^* \right]$$

$$St \rho^* \frac{\partial \vec{v}^*}{\partial t^*} + \rho^* (\vec{v}^* \cdot \nabla^*) \vec{v}^* = \left( \frac{g L_c}{U_c^2} \right) \vec{g}^* - \left( \frac{\Delta p_c}{\rho_c U_c^2} \right) \nabla^* p^* + \left( \frac{\mu_c}{\rho_c L_c U_c} \right) \left[ \frac{\mu^*}{3} \nabla^* (\nabla^* \cdot \vec{v}^*) + \mu^* \nabla^{*2} \vec{v}^* \right]$$

In which Reynolds number:

$$Re = \frac{U \cdot L}{\nu}$$

Reynolds specifies if the channel flow has high viscous forces ( $Re < 2300$ , Laminar) or low viscous forces ( $Re > 2300$ , Turbulent)

And Froude number:

$$Fr = \frac{U}{\sqrt{g \cdot L}}$$

Froude specifies if the channel flow is subcritical ( $Fr < 1$ , Perturbations travel upstream) or supercritical ( $Fr > 1$ , No transmission upstream).

#### 4.4.3. GEOMETRIC SIMILARITY CONDITION <sup>[19]</sup>

After considering the dimensional homogeneous of the expressions and obtained the dimensionless numbers, the next step is to solve the problem. It is advisable to build a model with a reduced scale of the prototype, which allows to size variables of the problem in a real scale. The main goal of the similitude is to define the conditions and to set up the transfer variable rules between model and prototype.

Regarding the geometric similarity condition, that is the base of any dimensional research. it has to fulfill the ratio between lengths. Like a scale, it is represented as  $E L_m : L_p$ , where  $L_m$  is the length of the model and  $L_p$  is the length of the prototype (Figure 38).

The basic problem of geometric similarity is that the variations of the geometric dimensions are so wide. In other words, they include geometric situations with dimensions of order of several meters with others whose order is about a tenth of millimeters. For instance, in a problem about flow in pipes, it can have a pipe of 10 m length, and to find the head losses an important parameter is the own roughness, which will be lower than 0.1 mm for a pipe made of galvanized steel. The ratio of both dimensions will be around  $10^5$ .



Figura 38. Geometric similarity (s6.aeromech.usyd.edu.au/aero/fluidmechanics7.php)

#### 4.4.4. KINEMATIC SIMILARITY CONDITION <sup>[20]</sup>

Apart from the geometric scales between the model and the prototype, another important condition to fix is the ratio of times between the model and the prototype, known as kinematic similarity. This sets up that in a flow given the motion of two particles, one in the model and the other in the prototype, are equivalent when they pass through equivalent positions at equivalent times (Figure 39).

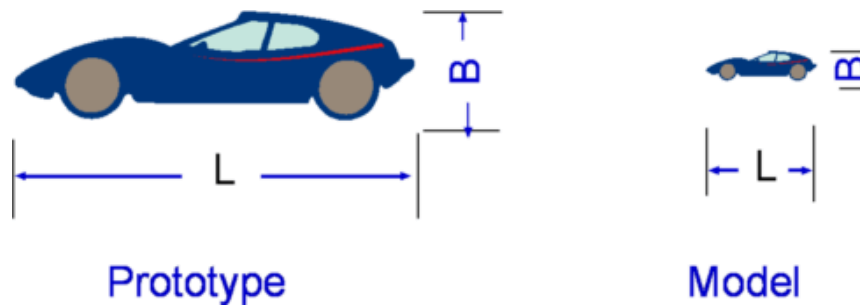

Figura 39. Kinetic similarity (s6.aeromech.usyd.edu.au/aero/fluidmechanics7.php)

Once fixed the geometric scale, the times scale is fixed as well. Unlike the geometric scale, to keep the same ratio of the kinematic similarity is difficult.

#### 4.4.5. DYNAMIC SIMILARITY CONDITIONS <sup>[20]</sup>

After fixing the geometric and kinematic similarities, it could be tested that the flow particles between the model and the prototype have a determined force relation. This condition is the most difficult to fulfill. However, it is used most of the time, because in the practice there is a main force, which tries to keep the scale between model and prototype through approaches more less exact to the rest of the forces exists in the flow (Figure 40).

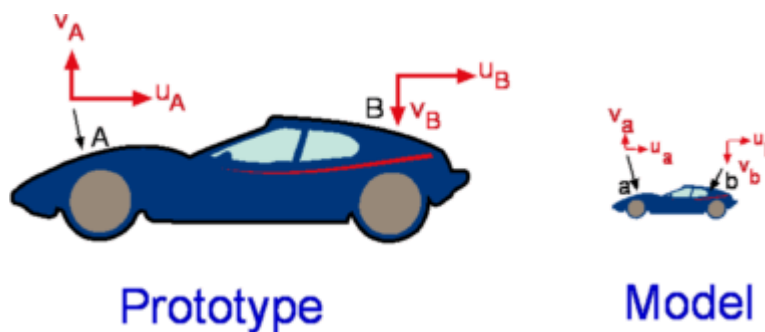

Figura 40. Dynamic similarity ([s6.aeromech.usyd.edu.au/aero/fluidmechanics7.php](http://s6.aeromech.usyd.edu.au/aero/fluidmechanics7.php))

If all these conditions are fulfilled, the similarity is total and all the dimensionless numbers obtained are identical for the model as well as the prototype.

To fulfill the dynamic similarity between model and prototype is physically impossible. To prove that, it is analyzed the impossibility to keep the dynamic similarity among three of the most common forces in every flow: inertial, viscous and gravitational force. Regarding the Second Newton's Law, inertial force is proportional to the mass multiplied by the acceleration:

$$F_p \propto M \frac{L}{T^2} = \rho \cdot L^3 \frac{L}{T^2} = \rho \cdot L \frac{L^2}{T^2} = \rho \cdot L^2 v^2$$

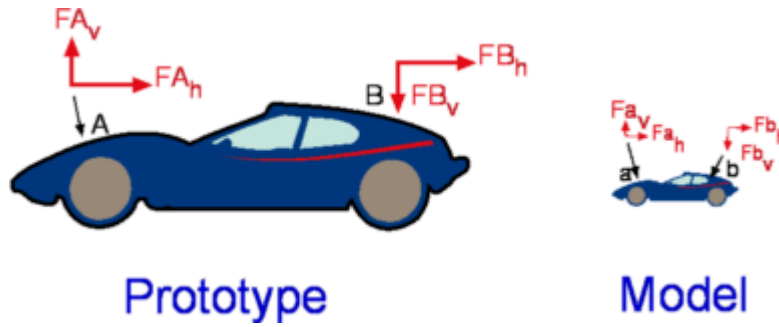
On the other hand, viscous force is proportional to shear stress multiplied by a reference area:

$$F_\mu \propto \left[ \left( \mu \frac{dv}{dy} \right) \cdot A \right] = \mu \cdot v \cdot L$$

The force ratio gives place to a dynamic similarity condition given by Reynolds number:

$$\frac{F_p}{F_\mu} = \frac{\rho \cdot L^2 \cdot v^2}{\mu \cdot v \cdot L} = \frac{\rho \cdot L \cdot v}{\mu} = \frac{L \cdot v}{\nu} = Re$$

If it is considered now the gravitational force:

$$F_g \propto m \cdot g = \rho \cdot L^3 \cdot g$$

The ratio between inertial and gravitational forces gives a second condition given by Froude number:

$$\frac{F_p}{F_g} = \frac{\rho \cdot L \cdot v^2}{\rho \cdot L^3 \cdot g} = \frac{v}{L \cdot g} = Fr^2$$

Both ratios are incompatible. If one condition is fulfilled, the other one cannot be fulfilled. However, in practical terms, the most important forces can be isolated and to apply the dynamic similarity between them, while the rest of the forces are subjected to empirical correlations, obtained from previous tests.



#### **4.4.6. SIMILARITY WITH FROUDE AND REYNOLDS** <sup>[20]</sup>

Froude number is used in open channel flows, where the main parameters are the gravitational and the inertial forces. According to Navier-Stokes equation, it is taken into account the gravity and the viscosity parameters. If the viscosity effects plays a neglected role in the flow stream when the Reynolds number is so high, gravity plays an important role, if the Froude number is so small. Therefore, the similarity with Froude is used in cases when the Reynolds number is so high and the Froude number is so small.

Regarding Reynolds number, it is used in streams happened in pipes. In this similarity, viscous forces are the main parameters. The main disadvantage of using this similarity is the scale ratios, like for the speed. For instance, if a prototype has a speed of 25 m/s, the model must have 1 m/s. To deal with that speed sizes, a good option is to test in a wind tunnel with air as the working fluid.

#### **4.4.7. SCALE EFFECTS** <sup>[20]</sup>

This effect appears when the prototype parameters are not scaled properly to the “small world” where the model is placed. As consequence, the force ratios are not the same than model and prototype.

Model tests always have scale effects when the ratio is different to 1, because it is impossible to correct all the force ratios, as mentioned in dynamic similarity. The larger scale ratio, the more the uncorrected force ratios deviate from the prototype ratios and the larger are the expected scale effects. Despite the fact that the scale ratio, this does not indicate whether or not the scale effects can be considered as negligible. The size of the scale effects depends on the phenomenon or parameter in a given model since the relative importance of the involved forces may differ. If one parameter is not considerably affected by scale effects, the other parameters may be affected. Finally, as the fluid forces are more notorious in scale model than in the prototype environment, the scale effects have an oscillating effect.

Regarding the dimensionless numbers, Froude number can present scale effects because of the incorrect considerations of the forces. It is nearly always identical between model and prototype. About Reynolds number, this is important for seepage flows, creeping flows around spheres or boundaries resulting in excessive losses in a model compared with its prototype.

There are different ways to reduce scale effect. With Froude number, it is advisable to satisfy limiting values of the force ratios. It is frequent to apply thumb rules, such as for bed load transport in a river expansion, the scale must be 1:55 with a grain size greater than 0.22 mm

or in a dam break wave research, with a dam of rectangular section there is a sudden failure, the still water depth must be greater than or equal to 0.3 m. Also, a replacement of fluid could be necessary, if the scale effects result from the kinematic viscosity of the fluid, typical tested in wind tunnels. The main problem of wind tunnels, that is, air models, are the not measurement of the gravity, free-surface and cavitation effects.

#### **4.5. FEASIBILITY OF USING 3D PRINTING IN HYDRAULIC ENGINEERING**

Along this chapter, the different types of hydraulic structures, as well as their functions have been explained.

Mentioned in chapter 4.2, almost 85-90% of the dams are embankment dams, which are the most economic dams, as well as technical, reasons for which these are the most common type of dams. However, earthfill embankment dams cannot be printed because of the materials which are made are not printable materials. Attending to the rockfill embankment dams, it is possible to print the sealing element, if this is made of concrete, through Contour Crafting.

On the other hand, in chapter 4.3, most of the fluid machineries are made of metal, superalloys mostly, those with nickel base. Because of that, the possible technologies to apply for the manufacturing of fluid machinery are SLS and Binder Jetting. Both use materials in powder form, including metals. The main disadvantage for both are the limited dimensions mentioned in chapters 2.2.3 and 2.2.4, as well as later processes, like sintering or metal infiltration. Because of binder jetting parts are porous before metal infiltration, it is advisable to avoid porosity in these components. Regarding the SLS, it is advisable to sinter these metal powders with a polymer to improve the strength. If the dimensions of the models are less than or equal to the limit for both technologies and the sintering is carried out, so the fluid machineries can be printed. Furthermore, the shapes of turbines and impellers are complex, therefore SLS and Binder Jetting are good technologies for complex geometries. After the printing, the fluid machinery need a coating process to gain strength against sediments or stones, which can appear in a flow stream, as well as to increase the stiffness of the machinery, a main disadvantage of the 3D printing models. In the case of casings made of concrete, where the turbines are placed, Contour Crafting can be used to print them.

Finally, regarding the chapter 4.4, about the scaling models used for testing before to build the final prototype, for the different hydraulic models, it must be used the similarity with Froude number. The streams generated in those structures are like in open channel flows. Apart from that, it is known that kinematic and dynamic similarity conditions cannot be

fulfilled at the same time. It is advisable to consider the kinematic similarity conditions in fluid machinery models, and the dynamic similarity conditions in dam models. Because of the layers, the own model can have a determined roughness, which generates a scale effect small in the model, maybe some millimeters of effect, but bigger in the prototype, some centimeters. To correct that, finishing processes like polishing are necessary to have a smooth model surface and to avoid, from this way, the scale effects produced by the 3D printing.

## 5. CONCLUSIONS

The thesis reviews the possibilities to apply 3D printing in hydraulic engineering, taking into account the materials, the technologies available in the market, the machinery, and the different hydraulic structures available nowadays. The most important issues are summarized as follows:

- 3D printing is an alternative to traditional manufacturing or construction, which has developed fast, but not yet enough.
- Most things created through 3D printing are made of thermoplastics, because of its easy access in terms of manageability and costs.
- The lack of reinforcement of printed concrete is a major issue, and it is needed to find additives or materials to add to the concrete and can be printed at the same time.
- Regarding the hydraulic structures, it is possible to print turbines and impellers, as well as scale models, fulfilling with the limits of the technologies.
- Hydraulic structures like dams are not possible by the moment to build through 3D printing, because of currently the materials used for their constructions are not printable.

## REFERENCES

- [1] Kalpakjian, S., & Schmid, S. R. (2014). Manufacturing engineering and technology: Chapter 20: Rapid-prototyping operations. Section 20.3: Additive Processes. Pearson.
- [2] Industry, 3. (2017). The Free Beginner's Guide - Materials. 3D Printing Industry. Retrieved 20 July 2017, from <https://3dprintingindustry.com/3d-printing-basics-free-beginners-guide/materials>
- [3] Hausman, K. K., & Horne, R. (2014). 3D printing for dummies: Chapter 4: Identifying materials for 3D printing. John Wiley & Sons.
- [4] 3ders.org - price compare 3D printing materials. (2017). 3ders.org. Retrieved 20 July 2017, from <http://www.3ders.org/pricecompare>
- [5] Frazier, W. E. (2014). Metal additive manufacturing: a review. *Journal of Materials Engineering and Performance*, 23(6), 1917-1928.
- [6] Le, T. T., Austin, S. A., Lim, S., Buswell, R. A., Gibb, A. G., & Thorpe, T. (2012). Mix design and fresh properties for high-performance printing concrete. *Materials and structures*, 45(8), 1221-1232.
- [7] Wietek, B. (2014). Faserbeton: im Bauwesen: Kapitel 4: Fassern. Springer-Verlag.
- [8] Hausman, K. K., & Horne, R. (2014). 3D printing for dummies: Chapter 3: Exploring applications of 3D printing. John Wiley & Sons.
- [9] Strati: The World's First 3D-Printed Car | Local Motors. (2017). Launch Forth. Retrieved 20 July 2017, from <https://launchforth.io/localmotors/strati-the-worlds-first-3d-printed-car/latest>
- [10] Yossef, M., & Chen, A. (2015). Applicability and limitations of 3D printing for civil structures.
- [11] Yurieff, K. (2017). New MIT robot can 3D print entire building structure in less than 14 hours. CNNMoney. Retrieved 20 July 2017, from <http://money.cnn.com/2017/05/02/technology/3d-printed-building-mit/index.html>
- [12] Krassenstein, B. (2017). World's First 3D Printed Office Building, Complete With 3D Printed Furniture & Interior To Be Built in Dubai. 3DPrint.com | The Voice of 3D Printing / Additive Manufacturing. Retrieved 20 July 2017, from <https://3dprint.com/77550/dubai-3d-printed-office>

- [13] Get over it! World's first 3D-printed bridge pops up in Madrid. (2017). Mail Online. Retrieved 20 July 2017, from <http://www.dailymail.co.uk/sciencetech/article-4184104/World-s-3D-printed-pedestrian-bridge-Madrid.html>
- [14] Novak, P., Moffat, A. I. B., Nalluri, C., & Narayanan, R. (2007). Hydraulic structures. CRC Press.
- [15] Strobl, T., & Zunic, F. (2006). Wasserbau. Springer-Verlag Berlin Heidelberg.
- [16] Pérez, J. G. (2010). Principios de mecánica de fluidos: Tema 12: Turbomáquinas. Sección 12.1: Máquinas de fluidos. Servicio de Publicaciones de la Universidad de Oviedo.
- [17] Minor, H.-E. (2008). Wasserbau: Kapitel 8: Zentralen, Krafthaus. Teil 8.3.3.1: Turbinenbauweise. ETH Zürich.
- [18] Malcherek, A. (2009). Hydromechanik für Bauingenieure. Vorlesungsskript in pdf-Form, Universität der Bundeswehr München, Neubiberg.
- [19] Pérez, J. G. (2010). Principios de mecánica de fluidos: Tema 6: Análisis dimensional. Sección 6.6: Teoría de modelos y semejanza. Servicio de Publicaciones de la Universidad de Oviedo.
- [20] Heller, V. (2011). Scale effects in physical hydraulic engineering models. *Journal of Hydraulic Research*, 49(3), 293-306.

## **Verpflichtungs- und Einverständniserklärung**

Ich erkläre, dass ich meine Bachelorarbeit selbständig verfasst und alle in ihr verwendeten Unterlagen, Hilfsmittel und die zugrunde gelegte Literatur genannt habe.

Ich nehme zur Kenntnis, dass auch bei auszugsweiser Veröffentlichung meiner Bachelorarbeit die Universität, das/die Institut/e und der/die Arbeitsbereich/e sowie die Leiterin bzw. der Leiter der Lehrveranstaltung, im Rahmen derer die Bachelorarbeit abgefasst wurde, zu nennen sind.

Ich nehme zur Kenntnis, dass meine Bachelorarbeit zur internen Dokumentation und Archivierung sowie zur Abgleichung mit der Plagiatssoftware elektronisch im Dateiformat pdf/A ohne Kennwortschutz bei der Leiterin bzw. beim Leiter der Lehrveranstaltung einzureichen ist, wobei auf die elektronisch archivierte Bachelorarbeit nur die Leiterin bzw. der Leiter der Lehrveranstaltung, im Rahmen derer die Bachelorarbeit abgefasst wurde, und das studienrechtliche Organ Zugriff haben.

Innsbruck, am 24.07.2017

.....  
Alejandro ARIZA GARCÍA