

ME519 MEng Group Project

3D Printing of Functional Parts and their Structural Integrity

Final Report

Group Q

Andrew Gilmour

Muhammad Fazril Abdul Latif

Martin Gutierrez Benito

Giovanni Ressurreição Piffer

Supervisor: Dr. Tugrul Comlekci

Website: <http://strath3dprinting.wix.com/strath3dprinting>

March 2016

Contents

Acknowledgements	iii
Definitions.....	iv
List of Figures	v
Executive Summary	vii
1. Background	1
2. Scope	2
3. Project Management.....	4
3.1 Project Management Requirements.....	4
3.2 Group Structure and Management	4
3.3 Project Timeline	9
3.4 Budget and Cost Management	10
3.5 Risk Management.....	12
3.6 Communication	15
3.7 Document Control	17
3.8 Workshop Arrangements.....	17
4. Additive Layer Manufacturing.....	19
4.1 Overview	19
4.2 ALM Technologies.....	19
4.3 The RepRap Project.....	21
5. Printer Selection and Assembly	22
5.1 Printer Selection	22
5.2 Assembly	23
5.3 Printer Features.....	24
6. Printing Process.....	29
6.1 Overview	29
6.2 Calibration	29
6.3 Print Surface Adhesion.....	31
6.4 Model.....	32
6.5 Slicing.....	34
7. Testing.....	40
7.1 Purpose	40
7.2 Experimental Work	41
7.3 Production of Samples.....	42

7.4	Tensile Testing	49
7.5	Results and Discussions	51
7.6	Conclusions	62
7.7	Future Work	63
8.	Microscopy.....	64
8.1	Objectives	64
8.2	Execution.....	65
8.3	Observations	73
8.4	Conclusions	77
8.5	Future Work	77
9.	Component Design and Printing	78
9.1	Challenges	78
9.2	Plotting Aerofoil Profiles	79
9.3	Design Concepts.....	81
9.4	Printing	83
9.5	Conclusions	91
10.	Analysis of 3D Printed Components.....	93
10.1	Problems with Analysis.....	93
10.2	Conclusions	95
11.	Project Conclusions.....	96
12.	Future Work	97
12.1	Printer Expansions and Upgrades.....	97
12.2	Testing of Printed Structures	99
13.	Reflection on Group Performance	100
13.1	Achievement of Project Objectives	100
13.2	Group Structure	101
13.3	Communication	102
13.4	Overcoming of Challenges	102
13.5	Time Management.....	103
13.6	Reporting	104
14.	References	105
	Appendix 1: ME519 Project Contract	
	Appendix 2: Test Data	

Acknowledgements

The group would like to extend a warm thanks to a number of individuals who have provided assistance, guidance and support to the group throughout the duration of the project. The group drew upon the knowledge and expertise of a number of staff members from the Department of Mechanical and Aerospace Engineering at the University of Strathclyde.

Firstly, thanks must be extended to Dr. Tugrul Comlekci who, as project supervisor, provided the necessary direction required to support the group throughout the entire project. His guidance and enthusiasm, particularly in the early stages, was crucial to the development of the project objectives and timeline.

Thanks must also be extended to the laboratory staff of the department. The group are indebted to a number of individuals who provided the assistance necessary to ensure the project kept moving. Specifically, the group would like to thank Mr. Chris Cameron who showed an enthusiasm towards the project and provided assistance and guidance on a number of issues. Thanks must also be given to Mr. James Gillespie who provided invaluable advice with regards to the use of the tensile testing equipment.

The group are also particularly thankful to Mr. Neil McCrindle and Mr. Jim Doherty of the department stores, who worked to meet the group needs at all times without question. Mr. James Kelly from the Metallography Laboratory and Mr. Gerry Johnston from the Advanced Materials Research Laboratory also played key roles in maintaining good progress, providing assistance on running analysis and acquiring images of vital importance in optical and electron microscopes, respectively.

Definitions

3D	3 Dimensional
ABS	Acrylic Butadiene Styrene
AIAA	American Institute of Aeronautics and Astronautics
ALM	Additive Layer Manufacturing
BMFA	British Model Flying Association
BS	British Standard
BQ	Spanish producer of 3D printing components
CAD	Computer aided design
CFABS	Carbon Fibre ABS
CFPLA	Carbon fibre PLA
CNC	Computer Numerical Control
DIY	Do It Yourself
FDM	Fused Deposition Modelling
FEA	Finite Element Analysis
FEM	Finite Element Modelling
FFM	Fused Filament Manufacturing
LM	Layer Manufacturing
LOM	Laminated Object Manufacture
mm	millimetre
OOKU	OO-Kuma
PLA	Polylactic Acid
PP	Proto Pasta
PTC	Parametric Technology Corporation
RP	Rapid Prototyping
RRG	Raster to raster gap
SEM	Scanning Electron Microscope
SLA	Stereolithography
SLS	Selective Laser Sintering
UIUC	University of Illinois Urbana-Champaign

List of Figures

Figure 1: Project timeline Gantt Chart	10
Figure 2: Assembled Prusa i3 Hephestos Printer.....	23
Figure 3: Annotated picture of 3D printer with modifications	24
Figure 4: Diagram of Extruder Assembly for BQ Hephestos [20]	26
Figure 5: Schematic of Filament Deposition [21].....	32
Figure 6: Schematic showing overhanging geometry [21]	33
Figure 7: Example of printed component with bridging [22]	33
Figure 8: Slicing preview of component in Cura.....	35
Figure 9: Example of the effect of changing layer height on complex geometry [23]	36
Figure 10: Examples of Infill Patterns [4]	37
Figure 11: Schematic showing different wall thicknesses [21]	38
Figure 12: Diagram of standard tensile test specimen as per BS ISO 527-2	43
Figure 13: (a) Diagonal infill pattern (b) Linear infill pattern	45
Figure 14: Different tool-path configuration (a) contour tool-path (b) raster tool-path [6] ...	45
Figure 15: Build orientation of diagonal pattern tensile specimen within print volume.....	45
Figure 16: Layer preview of diagonal infill tensile specimen.....	45
Figure 17: Build orientation of linear pattern tensile specimen within print volume	46
Figure 18: Layer preview of linear infill tensile specimen	46
Figure 19: Schematic of changing layer height	47
Figure 20: Optical microscope analysis showing air gaps within printed specimen.....	48
Figure 21: Schematic of tool-path parameters	48
Figure 22: Filament Sample Preparation method [6].....	49
Figure 23: Filament sample mounted in Instron tensile testing machine.....	49
Figure 24: Linear regression to obtain tensile modulus	50
Figure 25: Example of a specimen that has broken outside of the gauge length.....	52
Figure 26: Stress-strain curve of PLA samples. Legend:[orientation_layer height].....	52
Figure 27: Stress-strain curve of CFPLA samples. Legend:[orientation_layer height].....	53
Figure 28: Stress-strain curve of ABS samples. Legend:[orientation_layer height].....	53
Figure 29: Example of filament failing at epoxy end	54
Figure 30: Examples of fracture surface viewed under Scanning Electron Microscope (a) linear (b) diagonal	56
Figure 31: Tensile testing results from BQ PLA specimens.....	57
Figure 32: Tensile testing results from ProtoPasta Carbon Fibre PLA specimens	57
Figure 33: Performance of PLA tensile specimens against weight and printing time	60
Figure 34: Performance of CF PLA tensile specimens against weight and printing time	61
Figure 35: PLA test specimens – (a) x50 (b) x200 (c) x200.....	66
Figure 36: Carbon Fibre PLA test specimens - (a) x50 (b) x200 (c) x200	66
Figure 37: Linear PLA fracture surface (a) x15 (b) x40	67
Figure 38: Diagonal PLA fracture surface (a) x15 (b) x40.....	67
Figure 39: Linear CF PLA Fracture Surface (a) x27 (b) x90 (c) x100	67
Figure 40: Diagonal CF PLA Fracture Surface (a) x30 (b) x40.....	68
Figure 41: Diagonal PLA - (a) bottom corner (b) top corner (c) middle of top surface	68
Figure 42: Linear PLA (a) bottom corner (b) top corner (c) middle of top surface.....	69
Figure 43: Diagonal CF PLA (a) bottom corner (b) top corner (c) middle of top surface (d) middle near base	69
Figure 44: CF PLA filament perpendicular cross-section (a) x50 (b) x200.....	70
Figure 45: CF PLA filament longitudinal cross-section (a) x50 (b) x200	70
Figure 46: CF ABS filament cross-sections (a) perpendicular x50 (b) longitudinal x50	70
Figure 47: ColorFabb XT-CF20 Filament, longitudinal section x50.....	71
Figure 48: BQ PLA filament, longitudinal section x50	71
Figure 49: CF PLA linear infill specimen middle of base x50. (a) and (b) are different specimens	71

Figure 50: CF PLA linear infill specimen bottom corner x50. (a) and (b) are different specimens.....	71
Figure 51: CF PLA linear infill specimen mid height side wall x50. (a) and (b) are different specimens.....	72
Figure 52: CF PLA linear infill specimen x200 (a) top surface (b) bottom surface	72
Figure 53: CF PLA linear infill specimen (a) fracture surface (b) side wall	72
Figure 54: Printed Rib Creo Model.....	82
Figure 55: Profile of design concept utilising printed leading and trailing edges.....	82
Figure 56: Assembled section of aerofoil	82
Figure 57: Profile of All in One Aerofoil Concept	83
Figure 58: Rendered view of section of All in One Aerofoil.....	83
Figure 59: Leading Edge Orientation 1.....	86
Figure 60: Trailing Edge Orientation 1.....	86
Figure 61: Leading Edge Orientation 2.....	87
Figure 62: Leading Edge Orientation 3.....	87
Figure 63: Leading Edge Orientation 4.....	87
Figure 64: Leading Edge Orientation 4 with Support Material and Brim shown	87
Figure 66: Example of poor print performance achieved using orientation 2	88
Figure 65: Example of print achieved from orientation 4.....	88
Figure 67: Assembled fully printed aerofoil concept.....	89
Figure 68: All in One aerofoil Concept orientated as printed.....	90

Executive Summary

This project was undertaken as part of the MEng Mechanical Engineering degree programme within the Department of Mechanical and Aerospace Engineering at the University of Strathclyde. The project was ongoing throughout the duration of the academic year 2015-2016, beginning in September 2015 and reached completion in March 2016. The project was completed as the core of the ME519 MEng Group Project module. From the module descriptor form (MDF) document for the class, the aim of the project is as below.

“This module aims to give students an authentic experience of managing and contributing to a complex group project. This will include an opportunity to demonstrate mastery of the technical aspects of the project, in addition to demonstrating competence in project management, technical risk management and safety risk assessment.” [1]

The project was undertaken by Group Q, consisting of four students studying at the University of Strathclyde, with two members being full-time Strathclyde students and two members studying on exchange programmes at the University as part of their degree programmes. The project was supervised by Dr. Tugrul Comlekci, a Knowledge Exchange Fellow of the Department of Mechanical and Aerospace Engineering.

The project was proposed to investigate the potential of 3D printing using the fused deposition modelling (FDM) method to produce functional components with sufficient structural integrity to be used in the application of student projects. Particularly of interest was to establish the reliability of performance of low-cost, open-source 3D printing hardware and to identify potential performance improvements that can be achieved by using composite reinforced filaments that have come to market. The project utilised an open-source 3D printer developed as part of the RepRap¹ movement to undertake all printing. The printer used was a BQ Hephestos mark 1, a commercialised version of the popular Prusa i3.

The project investigated the effects of altering printing parameters on the strength and stiffness properties of printed parts and the differences that existed between

¹ <http://www.reprap.org>

different printing materials, particularly to draw comparison between plain plastic and composite-enhanced filaments. The project also established the reliability of the printing process on a low-end, open-source printer through microscopy analysis of printed specimens and how this varied with printing parameters.

The second aspect of the project was to evaluate the potential of 3D printing as an alternative manufacturing method for use in student projects, particularly in the application of aerofoil design and manufacture in scale flight competitions such as the AIAA flight competition. This saw alternative aerofoil constructions proposed as an alternative to the widely used balsa wood construction methods. From these, conclusions were drawn regarding the challenges and limitations with regard to design, analysis and printing of components using the FFM 3D printing method. Further to this, the group identified areas of further interest with regards to 3D printing of components in this application, particularly with respect to introducing composite materials to 3D printing.

1. Background

3D printing is a broad term, commonly used to describe a range of additive manufacturing techniques. In recent times the term has become more prominent in common knowledge as a technique for creating unconventional, complex, 3-dimensional shapes in a novelty fashion. However, the impact of 3D printing has been much more disruptive than many would be aware, with the continuous development of the techniques being described as the next industrial revolution [2].

As it has become a more accessible means of manufacturing bespoke, complex components in small quantities, attention is being turned to the use of 3D printing beyond the more commonly known novelty uses. Particularly of interest is the ability to create functional components that can fulfil load-bearing structural roles in engineering applications.

The advent of low-cost, open-source printer hardware has opened the potential for experimentation and research in this area up to nearly anyone and 3D printing no longer requires the high initial outlay that was once the case. This revolution in the availability of hardware brings with it the potential for more widespread use in educational roles. Specifically, the potential to introduce 3D printing into student projects as a method of manufacturing structural elements could yield new possibilities for design and manufacture.

The downside of the low-cost printing hardware to date has been in limitations of the materials that can be printed. Predominantly these printers utilise a fused filament method, and use a polymer filament to build up the layers, eventually creating the desired shape. These polymers have poor mechanical properties, and this limits the ability of the components to be truly load bearing, structural components. However, it is now possible to obtain polymer filaments that have been reinforced with chopped fibres, potentially improving the feasibility of printing structural components using low-cost hardware.

The printing process involves a number of stages, each of which are subject to parameters being set. The results of printing can be heavily influenced by the parameters selected, and in order to utilise 3D printing as a means to create structural components it is necessary to determine the influence of these parameters on the

performance of the printed parts. This is particularly true in the case of using composite reinforced filaments, whereby obtaining parts with improved strength and stiffness is the objective.

This project set out to investigate the performance improvements in terms of strength and stiffness that can be achieved by utilising the composite enhanced filaments, and identify the effects of parameter variation on the properties. Additionally, 3D printing as a means to create functional components was investigated, and conclusions drawn on the ability of this type of 3D printing to deliver good results. This aspect of the project will be focussed on the design of aerofoils to be used in student aeroplane build projects such as the AIAA flight competition as an example.

2. Scope

The scope of the project was based around a number of objectives that were set out in the project contract. This report describes the outcomes of the project with regards to these objectives as well as setting out information regarding management of the project and group structure, further research opportunities and reflection on the performance of the group.

Section 3 of the report sets out the management of the project: the group structure, project timeline and budget. Also covered is an assessment of the risks to the project that were identified and information about the organisation of the project, including communication and workshop arrangements that were agreed with the relevant parties.

The context of 3D printing within the broad area of additive layer manufacturing is set out in Section 4 and the fused filament manufacturing method described in detail. Further, the selection and build process of the printer are described in Section 5, representing the first of the project objectives. Section 6 describes the printing process in detail with relation to the printer hardware, giving a detailed description of the functionality of the printer.

Section 7 is focussed on the testing process, where it is described in depth, with detailed analysis of the results obtained in the testing phase. This section represents one of the main project objectives: to undertake mechanical testing to evaluate the

influence of printing parameters on the mechanical performance of printed components.

Section 8 covers the microscopy analysis carried out on printed components to establish the performance of the 3D printer. Of particular interest was the reliability and consistency of the printed parts on a micro-scale, thus analysis was undertaken on a number of sample configurations using both a scanning electron microscope and optical microscope. Also analysed were the individual filaments, to obtain information relating to the distribution of the chopped fibres within the filament.

Section 9 is focussed on the second objective set out in the contract: to investigate the potential of 3D printing as a method of manufacturing structural components in the context of student flight projects. The section covers the development of design concepts, and the printing process. The print testing process was iterative, with the effects of parameter variation and object orientation considered.

Section 10 introduces the issues of undertaking finite element analysis on 3D printed components. The requirement for being able to undertake this analysis is covered, some coverage given to the current work being carried out. Further, discussion is given to the direction that the future work in this area could be taken.

The report concludes with a summary of the areas identified throughout the course of the project as those where there is significant potential for future work to be carried out, or where the objectives of this work could be expanded. This then leads into an analysis of the performance of the group, identifying areas where the group worked well and where, on reflection, improvements could have been made.

3. Project Management

The sections below describe the project management procedures employed throughout the course of the project.

3.1 Project Management Requirements

The group recognised that in order to successfully complete a project of this scale, it was necessary to have formal procedures in place that set out the manner in which the activities involved in the project are completed. The success of the project was dependent on all the variable factors being effectively managed, as to do otherwise could hamper the progress and thus overall success.

The specific areas of the project workings that were considered as significant enough to require detailed consideration were the following:

- Group structure and management: each member of the group would be assigned roles and responsibilities based on their strengths and experience.
- Timescale and objectives: the objectives of the project would be considered within the overall scope, and a project timeline developed to establish how these would be met.
- Budget: the project budget would be subject to a project cost plan.
- Communication: a communication strategy would be set out to outline the methods of communication to be utilised, and provide guidance on their application.
- Risks: risks to the project would be considered as part of an overall risk assessment and risk management plan.

3.2 Group Structure and Management

The following sections give an overview of the group members working on the project, and give detail on the management structure utilised throughout the project.

3.2.1 Group Member Profiles

The project group consisted of 4 members, all of whom had a different background, previous experience and skills to contribute to the success of the project. Of the four members, two members were studying at the University of Strathclyde on exchange

from international universities: Martín from the University of Oviedo in Spain, and Giovanni from the Federal University of ABC in Brazil. The other two members of the group are full time students within the Department of Mechanical and Aerospace Engineering at the University, and are in their final of five years of study towards the MEng Mechanical Engineering degree. Andrew is a home student from Scotland, and Fazril is originally from Malaysia, joining the MEng programme at Strathclyde in 2013 after starting his studies in Kuala Lumpur. The clear differences in background and previous experience were identified, and it was recognised that this may affect the way in which the group was organised. After a familiarisation phase, where previous experience and areas of knowledge and interest were discussed, the group established roles and responsibilities for each member.

3.2.1.1 Andrew Gilmour

Andrew, originally from the Edinburgh area, has been studying on the MEng Mechanical Engineering degree course at the University of Strathclyde since September 2011, and is in his final year. Over his time at Strathclyde he has worked across a number of different engineering areas and has developed an interest and focus in the structural aspects of engineering. He completed his fourth year individual dissertation project under the supervision of Dr. Robert Hamilton of the Mechanical and Aerospace Engineering department. The focus of this project was on developing a fatigue analysis method using ANSYS and MATLAB, with a particular emphasis on fatigue assessment of components with surface to surface interactions, such as the case with a pin-loaded joint in an assembly.

For his fifth and final year he has selected a course of study that complements his previous study, as well as broadening his engineering knowledge and experience. This has involved undertaking modules in metallurgy, polymer composites, plasticity and pressure vessel design in the context of engineering, as well as courses in more broad engineering disciplines such as lean and six-sigma, advanced fluid systems, machine condition monitoring and renewable energy. Andrew also has a number of years of industrial experience in design and manufacture of support structures, primarily for the electricity supply industry.

3.2.1.2 Muhammad Fazril Abdul Latif (Fazril Latif)

Fazril started his first year degree in Manufacturing System at University Kuala Lumpur Institute of Product Design & Manufacturing (UniKL-IPROM), Malaysia and is currently a final year student on the MEng Mechanical Engineering course at the University of Strathclyde. In the early stages of his degree, he was introduced to basic mechanical engineering and product design related applications theoretically, which covered technical manufacturing strategy and also practically with the use of turning, milling, and CNC machinery. At Strathclyde, he completed his fourth year individual dissertation project that focused on the mechanical behaviour of fibre reinforced polymer composite at elevated temperatures under the supervision of Dr. Liu Yang of the Mechanical and Aerospace Engineering department. The project was mainly an experimental work of which mechanical testing machine for tensile, flexural and impact test were used and in depth fibre-matrix relation when subjected to load and temperature were investigated.

His interest towards composite materials has driven him to broaden his knowledge in materials science by undertaking modules covering polymer composites, engineering composites and engineering plasticity. In addition, as he aimed to be more universal in engineering, modules taken also include offshore engineering, marine renewable energy and pressure vessel design.

3.2.1.3 Giovanni Ressurreição Piffer

Giovanni, from São Paulo – Brazil, has been studying mechanics related courses since 2012. He is enrolled in the MEng Instrumentation, Automation and Robotics Engineering degree at the Federal University of ABC in Brazil, which he started in 2013, and is currently a full year exchange student in the MEng Mechanical Engineering degree course at the University of Strathclyde. Since the beginning of his studies he has worked across various engineering disciplines such as turning and milling machining as well as studies on cutting tools' properties and applications. Over his time at the Federal University of ABC he has grown an enthusiasm for mechanical engineering design and different CAD tools.

He has chosen to complete his exchange year in a mechanics related course in order to fulfil some of his knowledge desires linked with FEM/FEA and structural engineering topics, and develop more skills related to mechanical design. Giovanni

has profited from the range of modules offered by the Mechanical and Aerospace Engineering department in favour of studying engineering business and basic aerospace topics as well. He also has over 2 years of experience with mechanical drawing and draughting, mainly of heavy machinery and apparatus for milling.

3.2.1.4 Martín Gutierrez Benito

Martin, originally from Oviedo, Spain, has been studying mechanics related courses since 2012. He is enrolled in the MEng degree focused on Mechanical Design at the Escuela Politecnica de Ingenieria de Gijon, which is part of the University of Oviedo. Currently Martín is a full-year Erasmus exchange student in the MEng Mechanical Engineering degree course at the University of Strathclyde. Since the beginning of his studies he has developed an interest in topics such as CAD tools and part design and manufacturing. Martín has a keen and longstanding interest in 3D printing. In the year 2013 he built a 3D printer in his free time, which provided the group with some useful background knowledge for this project.

3.2.2 Roles and Responsibilities

In the initial stages of the project it was not clear which roles and responsibilities would be best suited to which member of the group, and so one of the first tasks was to establish a group structure that would run throughout the project. Developing a formal structure would ensure that responsibility for individual aspects of the project could be designated to the most suitable member of the group and responsibilities assigned in line with personal strengths and experience.

The structure of the group was developed to draw on the individual strengths of the group members, utilising their background and previous experience to the maximum level, and the roles designated as such. With only Andrew and Fazril being final year students (Giovanni and Martín being in their third and fourth years of study respectively) their familiarity to the workings of the University would be extremely beneficial, as well as having already completed substantial research studies in the course of their fourth year.

The major roles within the group were designated as below:

- **Project Manager:** The project manager was to have overall responsibility for the project and ensure that it progressed as desired, as well as ensuring

that the budget was managed suitably. The project manager was also a voice of authority on any contentious issues that arose within the group.

- **Communications Manager:** The communications manager had the responsibility of ensuring regular group communication and liaising with the academic supervisor as well as other members of staff.
- **Asset/Technical Manager:** The role of asset/technical manager was to have responsibility for the performance of group assets, such as the 3D printer.

On consideration of the skills and experience of the group, the roles were designated in line with Table 1.

Role	Group Member
Project Manager	Andrew Gilmour
Communications Manager	Fazril Latif
Asset/Technical Manager	Martín Gutierrez Benito

Table 1: Roles Assigned to Group Members

It was decided that the role of Project Manager was to be taken by either Andrew or Fazril, on account of their background within the University of Strathclyde. It was finally decided that the role was best taken on by Andrew, due to having experience working in industry. It was also realised that with Fazril's previous work in fourth year being in testing of polymers, he would also take on the responsibility of overseeing the testing phase of the project.

Once the project plan was developed it was clear that the project would have two main working areas: material testing and design. Underneath the management structure, which served to manage the administration of the project, the group worked largely in two working groups, one for each of these areas. The responsibility for managing the testing aspects of the project was taken by Fazril, while Martín was to lead the design activities. Within these areas, the group members worked flexibly to meet the demands at any given time, with resources being shared effectively across the two areas. This created an efficient structure for overseeing both the management and administration of the project, as well as ensuring technical progression.

3.3 Project Timeline

The project timeline was set out as a Gantt chart in Microsoft Project as a means to establish the timescale of the project and the activities that were to be completed. A Gantt chart is effective in showing the overlap between tasks and gives an indication of the critical path - those activities that, if delayed, will hamper the overall success of the project. The group found that Microsoft Project was a frustrating programme to use, as it did not always facilitate planning tasks in the manner that the group would have liked. This is reflected in the format of the Gantt chart, where the connections between tasks are not as would ideally be desired. It was found that adding connections between tasks would move the dates of tasks around in an unsatisfactory and unacceptable manner, and so it was decided to limit the use of the task connection functionality. The group accept that this is not the ideal situation, but it was deemed to be of little importance to the overall success of the project.

The Gantt chart was revised at a number of times throughout the duration of the project to account for any changes that were required, with the final version being as Figure 1. These changes mostly arose due to unforeseen delays, or changes in the direction of the project that affected the constituent activities. Many of the tasks, particularly printing and testing of specimens took place in parallel. This can be explained by the unpredictable pace at which printing of specimens could be achieved, and the somewhat unpredictable nature of the printing process, particularly in the early stages. In particular, the printing of the PLA specimens took significantly longer than was initially anticipated, as issues were encountered in getting the samples to print well, without distorting or becoming unstuck from the print bed. This significantly impacted the progress towards the end of the first Semester, and subsequently raised the importance of installing the heated bed to the highest priority at the start of Semester 2. Once this was installed, the printing schedule was predictable with much more reliable printing performance being achieved, however the rate at which specimens could be printed was still low, as the process was inherently slow.

At the end of the first Semester the progress the group had made was analysed and the decision was made in conjunction with the project supervisor to slightly alter the original scope of the project. It had originally been set out that the group would

modify the printer to expand its print area, however at the end of Semester 1 it was clear that the printing process was slower than had been anticipated, and so it was accepted that the best course of action would be to overlook this deliverable in order to catch up with specimen printing. The reason for this was that modifying the printer would have rendered it out of action for some period of time, and it was not known if the process would also introduce further delays in getting the printer running reliably again.

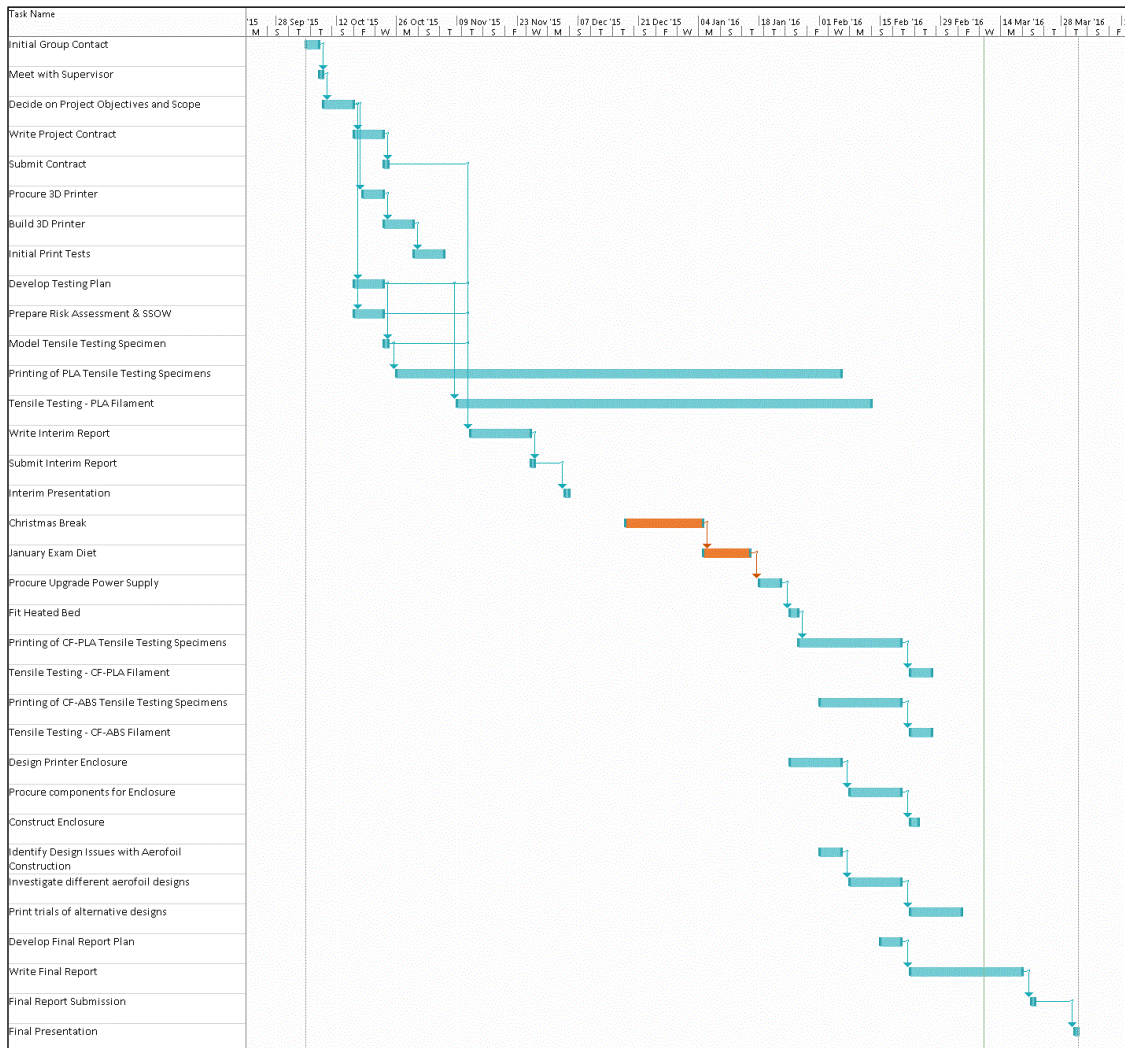

Figure 1: Project timeline Gantt Chart

3.4 Budget and Cost Management

The project had two sources of funding, from which all purchases had to be made. A sum of £100 per group member was assigned by the Department of Mechanical and Aerospace Engineering at the University, giving a total of £400. In addition to this,

the project supervisor Dr. Tugrul Comlekci had funds available to the group. However, this additional funding was subject to negotiations with the supervisor.

It was agreed with Dr. Comlekci that the printer would be purchased from his personal research budget, and that all other costs should be covered by the centrally assigned budget. In order to keep track of funding it was essential to maintain an up to date record of project spending. This was held as an open document within the cloud document storage system used by the group so that all group members could view and edit the spreadsheet.

The spending on the project is detailed in Table 2 below.

Item	Supplier	Cost/Unit	Quantity	Delivery & Shipping	Line Cost
BQ Hephestos Prusa i3 3D Printer – Self-build kit	daemon3dprint.com	363.54	1	0	£363.54
Prusa i3 Heated Bed Upgrade Kit	daemon3dprint.com	34.81	1	0	£34.81
BQ PLA filament	daemon3dprint.com	14.59	1	0	£14.59
OO-Kuma CF0 Carbon Fibre ABS filament	OO-Kuma.com	32.96	1	9.71	£42.67
OO-Kuma Filament Customs Charges	DHL	18	1	0	£18.00
ColorFabb Carbon Fibre XT-CF20 filament	e3d-online.com	38	1	2.75	£40.75
Proto-pasta - Carbon Fiber Reinforced PLA filament	e3d-online.com	20.5	3	2.75	£64.25
Power Supply for Heated Bed	RS Online	45.53	1	0	£45.53
Bearings + Hinges	RS Online	6.07	2	0	£12.14
Aluminium Struts for Enclosure (+ Connectors)	RS Online	17.89	3	0	£53.67
Enclosure Connectors	RS Online	6.18	8	0	£49.44
4mm Acrylic Sheet for Enclosure	Stockline Plastics	39.6	1	0	£39.60
Replacement Glass Print Bed Plate	Amazon.co.uk	9.99	2	0	£19.98
				Total:	£798.97

Table 2: Project Expenditure

The total project expenditure was £798.97. The printer, heated bed and BQ PLA filament were purchased from Dr. Comlekci's personal budget, with all other costs being covered by the group budget. The total expenditure from the group budget was £386.03, within the £400 limit set out by the department.

The majority of the expenditure was planned and predictable, such as the printer and consumables. There were, however, a number of unexpected expenses, the need for which only became apparent as the project progressed. It was therefore beneficial that the group had taken into account the potential for requiring replacement components or further consumables. The enclosure that was designed and built by the group was required in line with the request of the supervisor to meet health and safety requirements due to the fact the printer had both hot and moving parts.

3.5 Risk Management

It was recognised that the project was susceptible to a number of risks that could impact both the progression of the project and the extent to which final objectives were met. The following sections discuss the actions that were taken to limit the impact of risks.

3.5.1 Risk Identification

It was recognised that the progression of the project could be hampered by numerous factors. Consequently, it was deemed important to devise an assessment of the risks to the project and identify any action that could be taken to reduce or eliminate the risks where possible. The risks were assessed on a likelihood and severity rating (from 1 to 5), which in turn was used to determine the risk rating corresponding to that particular risk. The risk rating classifications used were as Table 3 below.

Risk Rating	Risk Category
1-8	Low
9-16	Medium
17-25	High

Table 3: Risk rating categories

Risk	Description	Likelihood, L (1, 2, 3, 4, 5)	Severity, S (1, 2, 3, 4, 5)	Risk Rating (LxS)	Proposed risk reduction measures (if applicable)
Team member illness or injury	Team member illness or injury will limit the human resources available to work on the project and would necessitate redistribution of tasks.	2	3	6	Where possible tasks will be assigned to the absent member that can be completed without being present. They will be kept up to date by electronic communication should they be absent for group meetings.
Supervisor absence	Extended periods of absence of the supervisor may hinder the progress of the project.	1	2	2	
Team member commitments to other projects/classes	There may be times where team members are committed to other class activities (exams, tests, assignments, etc.).	4	3	12	Team members will identify times where this may be the case and communicate these to the other group members, and the schedule can be adjusted to suit.
Lab unavailability	The progress of the project is reliant on the lab space being available. Unavailability could seriously delay the project.	3	5	15	The group will liaise with the lab technician Mr. Chris Cameron to negotiate access times and a designated area in the lab.
Printer failure	The project is reliant on the functionality of the printer being maintained.	3	5	15	The group will operate the printer in line with an agreed safe system of work procedure and risk assessment. Regular inspection and maintenance will be carried out to ensure functionality is maintained.
Testing equipment unavailability	The unavailability of testing equipment may adversely affect the progress of the project.	3	3	9	The Head of Testing will ensure that testing machines are booked in advance by liaising with the lab technician, Mr James Gillespie.
Data loss	Unexpected loss of data could cause delays to the project.	1	5	5	All data should be backed up in multiple locations. A cloud-based storage system will be utilised by group members to ensure

					the safe keeping of critical files. See communications strategy.
Delay of parts/material delivery	Delays in receiving parts and/or materials may hinder the project progress.	2	1	2	Material should be ordered well in advance of them being required.
Funding	Poor budget management may lead slow progress and failure to meet targets.	1	2	2	The project budget should be managed strictly, and if a problem is foreseen, this should be raised with the supervisor.
Safety of group members	The 3D printer has many moving parts and high temperature components that could pose a risk to group members or other lab users, or damage the printer, thus delaying the project.	2	2	4	The group shall ensure to adhere to the University's Health and Safety requirements and ensure a risk assessment is completed. It may be necessary to enclose the 3D printer.

Table 4: Identified risks to project progress

3.5.1.1 Safety of Group Members

The group members would be actively and regularly working in a workshop setting to complete the project and thus it was necessary to undertake a risk assessment of group activities to comply with the health and safety requirements of the University. This was carried out in accordance with the guidance documents and covered all aspects of the group's work with the 3D printer and tensile testing machinery that would be used. In addition to this, to complement the risk assessment, a Safe System of Work document was developed for the 3D printer that set out the safe working procedure for using the printer. This document was agreed to by all group members and was followed by the group members when using the printer. A copy was also supplied to the project supervisor and the lab safety superintendent for their reference.

3.5.1.2 Timescale

Since 3D printing was a new process to most group members, there was little understanding of the timescales involved. This was problematic when identifying the scope of the project and defining the activities of the project. It was thus recognised that the timeline of the project would need to have a degree of flexibility, and that this may affect the overall achievement of the project. This was discussed with the group project supervisor, and it was agreed that the scope of the project may have to

change as the project progressed, due to time constraints and unforeseen scheduling issues.

3.6 Communication

3.6.1 Communications Strategy

The group recognised that, as with any large project, having an effective communication strategy would be paramount to achieving success. The communication methods employed by the group existed to meet specific purposes within the overall framework of the project, with the suitability of each method being graded on its speed, traceability, and formality. The group recognised the benefits of electronic communication and were keen to utilise this where possible, but also saw the need for regular, formal, meetings to keep track of progress.

It was set out by the group that not all communication in the project would hold the same status, and so a communications framework was developed to ensure that the communication method employed was appropriate for the purpose of that communication. The framework also served to identify how often communication should be made between the parties involved in the project. For each communication method identified by the group, guidance was issued outlining its intended purpose, the individuals involved and the foreseen frequency, as in Table 5.

Method	Format	Function	Involved Parties	Foreseen Frequency
Formal Team Meeting	In person	<ul style="list-style-type: none"> · Discuss current project progression. · Discussion of problems encountered. · Discuss delays encountered, and identify cause. · Identify changes in future schedule. 	All team members	Weekly
Team Meeting with Supervisor	In person	<ul style="list-style-type: none"> · Discuss project progress. · Discussion of concerns or queries. · Negotiate on any changes to scope of project. 	All team members; Project supervisor	Fortnightly
Informal Team Meetings	In person, in the lab	<ul style="list-style-type: none"> · Work on current activities · Discuss progress/delays 	Available team members	3-4 times weekly
Team Progress Update	Facebook Group Post	<ul style="list-style-type: none"> · Summarise tasks completed to date. 	All team members	Weekly

		<ul style="list-style-type: none"> · Identify areas of work for following week. · Progress to meet long-term goals. 		
Instant Messaging	Facebook Chat	<ul style="list-style-type: none"> · Quick and informal discussion of pressing issues. · Update on group member availability. · Share thoughts and ideas quickly. 	All team members	When necessary (daily)
Supervisor E-mail	E-mail	<ul style="list-style-type: none"> · Formal contact to supervisor between meetings. · Requests for advice. 	All team members; project supervisor.	When necessary
Contact to Other parties	E-mail	<ul style="list-style-type: none"> · Formal requests for information. · Purchase requests. 	Team members; University staff; outside companies.	When necessary

Table 5: Communications Strategy

3.6.2 Weekly Updates

Each week a summary of the group activities was posted to the group members within a closed Facebook group by the project manager. This served to update all members on the progress made and the objectives for the coming period. This was an effective method of communicating progress as it kept regular track of group activity and highlighted any problems that needed tackled. The benefits of this method rather than email communication is that group members could quickly acknowledge that they have seen the post (as well as the project manager being able to see this) and also facilitated easy discussion and reply through the structured comments system.

3.6.3 Group Meetings

The group maintained regular contact with each other in person by their presence in the lab, however it was not always common for all members to be present at the same time. For this reason, at least once per week the group set a time to have a meeting. This meeting complemented the weekly updates, where any issues that arose from these could be discussed in person. Since the meeting followed the weekly summary posting, the members knew what issues were being encountered, making efficient use of time at the meeting as thoughts could be gathered in advance.

3.7 Document Control

The group identified the risk of data loss as being small, but potentially severe, and so steps were taken to ensure that any documents were suitably backed up. As a tool to facilitate this, the group made extensive use of cloud-based storage, primarily Google Drive. The benefits of using this type of storage were numerous, as it enabled collaborative contribution as well as secure and resilient storage, reducing the impact of local data storage. Cloud storage also allowed document versions to be managed effectively, by taking the most recently uploaded version to be the most recent. Additionally, the version management function of Google Drive was utilised to maintain an archive of old versions. An example of the benefit that this presented was in maintaining the expenditure spreadsheet, as all group members could be safe in the knowledge that they were viewing or editing the most current version.

The group also maintained a Facebook group for more informal sharing of documents and ideas. This was more suited to this task as it was more readily available to group members, particularly through mobile devices. It also allowed the main Google Drive folders to be kept for more important documents.

The group also set up document templates in order to ensure that consistency was maintained across documents. This was a simple but effective measure. With templates having titles and other formatting set up from the beginning, working on collaborative documents such as reports was simplified as documents could be merged with little hassle.

3.8 Workshop Arrangements

The group required a dedicated space where the printer and other supplies could be stored, as well as somewhere for the group to work in. This required negotiation with the lab technicians in the Department of Mechanical and Aerospace Engineering workshops. It was decided in conjunction with Mr. Chris Cameron that the group could have exclusive use of a desk at the back of the upper level M5 workshop. This gave the group space to base the printer which would always be available during the opening hours of the workshop.

Also within the workshop, the group were assigned a locker that could be used to safely store all items associated to the project, particularly printer consumables,

spare parts and tools. The locker also served as a central depository for all printed specimens, meaning that all group members had access to these should they require. A list of specimens to be printed for the testing phase was also maintained and kept in the locker so that any member going to the lab knew which specimens were required next, in line with the testing requirements set out.

4. Additive Layer Manufacturing

4.1 Overview

Additive layer manufacturing (ALM) is rapidly transforming from a costly, complex process to a mainstream, low-cost and low-waste manufacturing method that is being adopted by many traditional industries. Once the reserve of hobbyists and high-budget research and development teams, additive layer manufacturing is fast becoming more accessible, due to the availability of low-cost, open-source hardware and associated software, as well as a vast online community of creators sharing designs and expertise.

The term additive layer manufacturing is a broad term that encapsulates a number of different techniques, primarily selective sintering or material deposition. There are benefits and drawbacks related to each technique, as well as limitations on their use relating to material selection or required resolution. In general, sintering techniques will provide a higher-resolution, albeit more costly product with deposition methods being lower-resolution, with associated lower costs. The commonly used term ‘3D printing’ is mostly associated with the material extrusion process where material is passed through an extrusion nozzle which follows a defined path to build up the material layer by layer to create the 3D geometry.

What is common with all techniques is the necessity to discretise the geometry of the component into layers by a process called slicing. This sliced geometry is used to produce the control file for the printer – it is discussed in detail in Section 6.5.

4.2 ALM Technologies

There are a number of technologies available that fall under the umbrella term of additive layer manufacturing, with each having associated benefits and drawbacks. A number of common technologies are discussed in the following sections.

4.2.1 Stereolithography (SLA)

This method forms 3D geometry from a pool of resin where the layers are formed as the resin is cured to a solid form. In this method, the resin is cured by an ultraviolet laser that scans across the surface, tracing the geometry layer by layer. Typically the resolution that can be achieved by SLA is very high, and so the quality of the

finished part is very high with surfaces being smooth due to the small layer height. The method is versatile as different resins can be used that give the finished part different properties, such as elasticity. The primary downside to SLA is that it is an expensive process, with the hardware being costly and the cost of resins is also significant.

4.2.2 Selective Laser Sintering (SLS)

This method was first developed in the 1980s and also uses a computer controlled laser to form the final geometry. In SLS, instead of a resin, an excess of powder material is used, with the print base being covered by a thin layer which is then melted by the laser to form a layer of the finished component. The base moves down one layer at a time and the process is repeated, allowing the part to be built up from bottom to top.

SLS is commonly used in prototyping as it can be used with a wide range of materials (including some metal powders) and there is no need for supports to be included in complex, intricate parts. This is due to the excess of powder which acts as a support, which can then be removed in a post-processing phase. Again, the benefits of SLS are plentiful; however the cost is significant of both the materials and the machine itself. A similar technique, known as electron beam melting (EBM) follows a similar procedure, however an electron beam is used to fuse the layers of material rather than a laser. Using an electron beam allows other materials to be used, particularly an expanded range of metal powders.

4.2.3 Laminated Object Manufacture (LOM)

This method consists of a physical layer of material that is then cut and fused to the next layer. This is often done using layers of paper, plastic or metal that can be laser or blade cut before they are fused. The excess material can then be removed to leave the final form. This technique can be cheap and fast, however the final parts produced are of no functional use, and so the use of LOM is restricted to concept development where artists or designers can see their designs in 3D quickly and cheaply using a paper and glue system.

4.2.4 Fused Deposition Modelling (FDM)

Fused deposition modelling can describe a number of techniques where layers of material are deposited by a print head on top of the previous layer. The most common FDM method is fused filament manufacturing (FFM) where a continuous plastic filament is passed through a heated extruder nozzle to deposit a thin, molten strand of plastic on the layer below. The heated plastic fuses to the adjacent layers, before it cools and hardens, gradually forming the desired form.

FFM printers normally use thermoplastic filaments, so the components produced can be used for a range of purposes depending on the characteristics of the filament. However, the functionality of these printed components in load-bearing applications is limited, since their strength and stiffness is dictated by the filament material, and the strength of the bonds formed between adjacent strands and layers. Printers that have been designed as part of the RepRap project utilise the FFM method since the hardware required is relatively simple and low cost, as well as the print material being low cost and readily available.

For these reasons, this project is concerned with investigating the functionality of components produced using the FFM technique. The simple and low-cost nature of the devices as well as low-cost print materials being available makes this method suitable for student projects, and with the range of filament materials available it is envisaged that it will be feasible to produce functional parts.

4.3 The RepRap Project

Within the world of 3D printing, there is a plethora of hardware options available. Many commercially designed and produced printers are now available such as the popular models produced by Ultimaker and Makerbot, however the cost is still significant by some metrics, although significantly lower than printers using other printing techniques. Along with these commercial models there is a growing community of open-source designs that form the RepRap community, that are available at very low cost.

The idea behind the RepRap movement is that the printer designs are open-source, and so can be customised and modified to the individual needs of each user. Additionally, the designs are such that the printer can be assembled using as many

regular components as possible, with any plastic parts being printable using another RepRap 3D printer. This has given rise to a number of successful designs being made commercially available on a large scale at costs significantly lower than commercially designed models and this has opened up a range of opportunities to produce customised components and parts quickly, easily and cheaply.

5. Printer Selection and Assembly

5.1 Printer Selection

For the project it was important to select a printer that met a number of key criteria:

- The printer must be able to print a range of different materials, primarily the most common printing filaments of ABS and PLA, as well as the ability to print filaments with added fibres. This criterion dictated that any options considered must have a high quality extruder and nozzle, as well as the option of a heated print surface, essential for printing of ABS.
- The printer must be capable of printing using files created using common slicing software.
- It must be capable of manufacturing printed parts consistently and reliably. This reliability should be in terms of both dimensional consistency and material adhesion.
- It must provide a base framework that can be expanded in size to print larger components if necessary in future.
- The printer must be available at a price consistent with the budget allocated by the project supervisor, which is less than £450.

Within the RepRap community, the Prusa i3 printer is a highly-regarded and well rated 3D printer utilising the FFM method. The printer design was first developed by Joseph Prusa within the RepRap project, and the i3 is the third iteration of the design. The design itself is open-source, however it has been commercialised by a number of companies that offer self-build or fully-assembled and calibrated versions. To maintain adherence to the allocated budget, it was decided that the self-build option would be more suitable, as it would not only lower the cost to purchase the printer, but also allow the group to gain a more thorough understanding of the workings of the printer.

With regard to selection of a commercialised self-build version, the Prusa i3 Hephastos manufactured by Spanish company BQ was selected due to its ease of availability and ability to add a heated print bed. Additionally, the Hephastos printer

is the subject of a wealth of support material online. This is beneficial for any instances where problems are encountered.

5.2 Assembly

On receiving the printer the assembly process was a relatively straight-forward process, as the documentation supplied allowed the process to be easily followed. The printer has been designed to be assembled easily, and all the plastic parts are themselves 3D printed. The other components are basic, readily available components like threaded rod and solid bar along with readily available connectors. This simplicity will be beneficial if the printer is expanded later on in the project. Figure 2 shows the fully assembled printer.

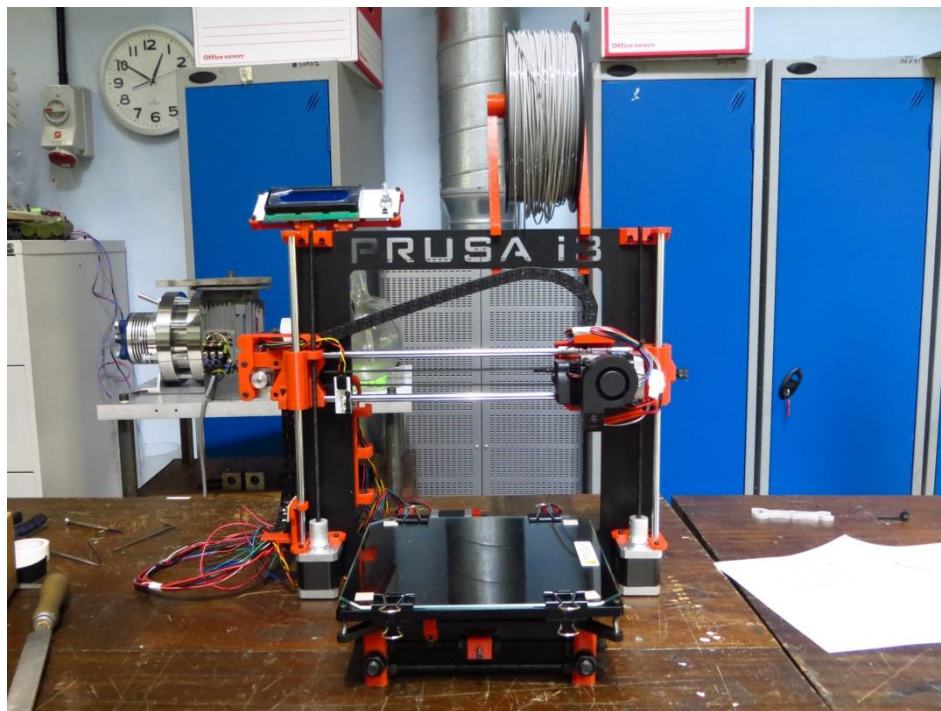

Figure 2: Assembled Prusa i3 Hephestos Printer

A number of difficulties were experienced during the assembly, but most were easily rectified. The first problem encountered occurred when inserting the z-axis bars inside the linear bearings, where the end of the bar dislodged one of the bearings. As the bearings are small, it was difficult to put this back in place and although was returned to its rightful place, it was not as smooth as it was initially. The second and more confusing difficulty was found when connecting up the wiring for the electronics. The electronics are fairly straightforward and consists of 4 stepper motors, 3 axis end-stop sensors and the pre-assembled hot-end assembly consisting

of the heated nozzle, the extruder motor and the fans. This is all connected to an Arduino controller via flexible wire with pre-fitted connectors, making connections straightforward. The difficulty arose in that the wiring diagram provided did not match the reality, and when the motors were connected and turned on, they were operating in the reverse direction. This was quickly solved by reversing the direction of the connectors.

5.3 Printer Features

5.3.1 Overview

A fused deposition modelling 3D printer is essentially a 4-axis CNC machine. Figure 3 shows an annotated image of the assembled 3D printer used for the project. This is the final version of the printer that has a number of upgrades from the original printer, as in Figure 2. The following sections describe each of these features.

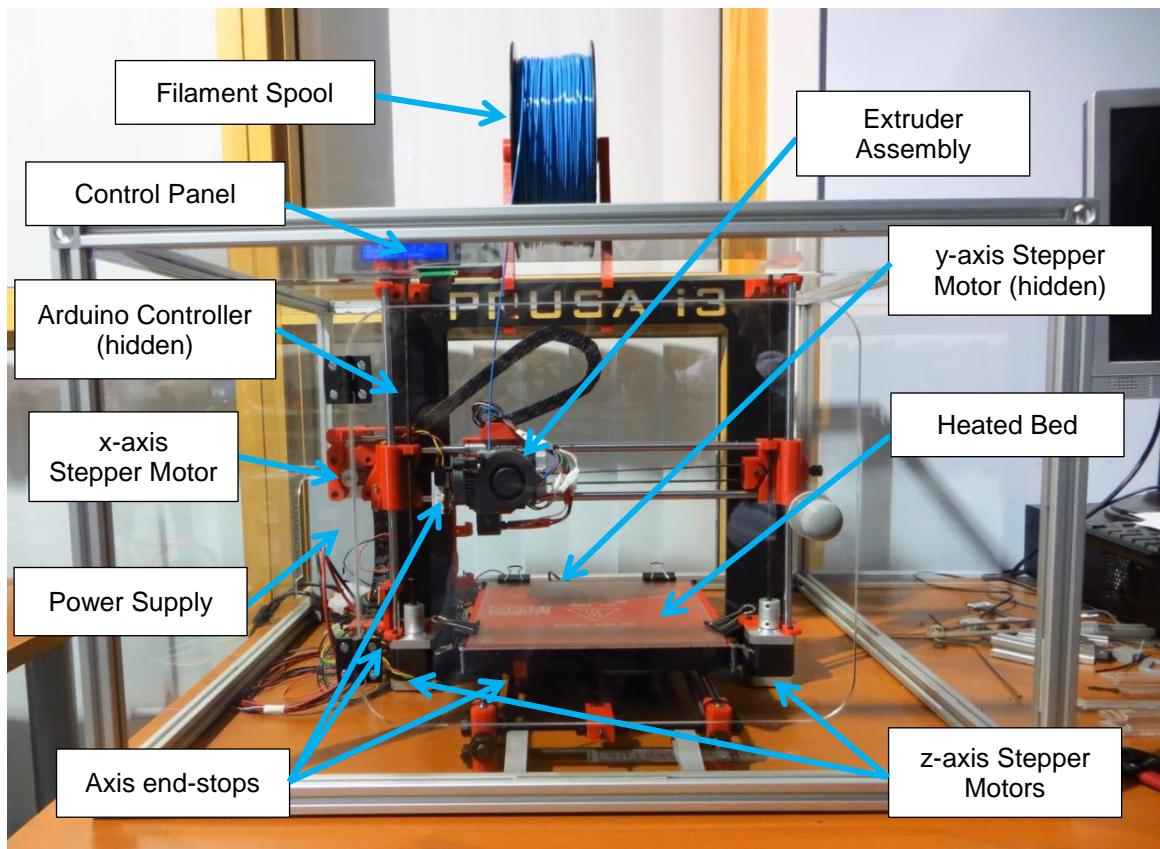

Figure 3: Annotated picture of 3D printer with modifications

5.3.2 Stepper Motors

The hot-end assembly is moved along the three linear movement axes by stepper motors that are controlled by the Arduino controller. There are 4 stepper motors that

move the hot-end: one for the x-axis movement, one for the y-axis and two for the z-axis. Controlled to act together, these motors allow the nozzle to be moved to any position within the print volume of the printer. For this printer the print volume is approximately 200x200x200mm.

The x and y-axis motors translate rotational movement into linear movement by means of a belt and pulley arrangement. For the x-axis, the stepper motor drives a belt connected directly to the extruder, and since the extruder is constrained to move along the parallel round bars, accurate positioning can be achieved. For the y-axis, the motor again drives a belt, but in this case the belt is connected to the print bed, and so rotation of the motor creates linear motion of the print bed. The combination of these two operating together allows full x-y movement.

The z-axis is controlled by two motors, each of which turns a threaded rod through a constant direction coupling. The coupling is required as the threaded rods are a low-quality component, and are not completely straight. The two motors act together to control the height of the extruder above the plate. Each axis has an end-stop switch that acts as the home position for each axis. When triggered, the motor is stopped by the Arduino to prevent damage to the printer or motors.

5.3.3 Extruder Assembly

The extruder assembly encompasses a number of individual components that together control the extrusion and deposition of the filament material. The assembly consists of a stepper motor, a heater, a thermistor, the nozzle and a fan, as can be seen in Figure 4.

The stepper motor is connected to a hobbed bolt that grips the filament that is fed from the spool and allows it to be drawn into the extruder. The filament is then heated by the heater, which is thermistor controlled. The thermistor allows the temperature to be regulated by the Arduino, as well as allowing a measure of the nozzle temperature to be displayed on the control panel. The heater melts the filament to form a pool of molten material, and the stepper motor then controls the pressure exerted on this pool by the solid filament above it. This forces the molten plastic down through the heater and out from the nozzle where it is deposited to create the part.

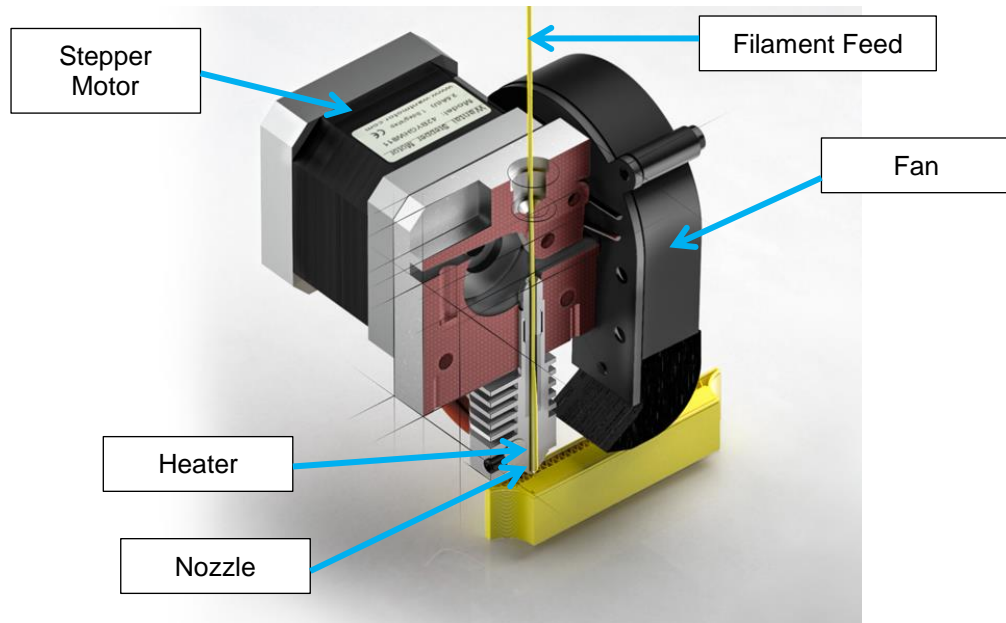

Figure 4: Diagram of Extruder Assembly for BQ Hephestos [20]

The fan is a feature not found on all extruder assemblies but is one that increases the capability of the extruder. The fan is also controlled by the Arduino and is positioned such that it quickly solidifies the extruded material. This capability increases the ability of the printer to print across gaps (bridging) or overhanging regions, since the material is solidified very soon after it leaves the nozzle, thus it exhibits better properties and does not sag.

5.3.4 Heated Bed

The heated bed is in essence a thin, flat, printed resistor through which a current flows to produce heat. It is controlled by the Arduino and the temperature to which it is heated can be set to suit the material being used or the specific application. It can be heated to around 100°C, however at more elevated temperatures the current being drawn is high and the temperature it operates at is not as stable. It was necessary for the firmware on the Arduino to be updated from that with which it was supplied in order to add the heated bed functionality. The updated firmware was obtained from BQ, however this version was incomplete. The remaining required code was sourced from the original Marlin firmware developers on GitHub. This was then compiled and loaded on to the Arduino.

The heated bed was added to the printer to allow it to be able to print a wider range of materials as well as to increase the reliability of the printer, since it helps parts

adhere to the print surface and prevents warping as the temperature gradient within the component is reduced. Reducing the temperature gradient reduces the tendency of components to warp as they cool down, an effect that is especially pronounced when printing with ABS-based filaments or large, flat components such as tensile specimens.

5.3.5 Power Supply

The power supply pictured in Figure 3 is an upgraded supply, the need for which was dictated by the addition of the heated bed. As mentioned above, the heated bed is capable of drawing large currents, and the original power supply supplied with the printer was not appropriately rated for this. The original power supply was what many would be familiar with as being a laptop power supply, and was rated at 120W. The upgraded power supply was sourced from RS Components, and is rated to 350W.

5.3.6 Control Panel

One of the main benefits of selecting the BQ Hephestos printer was that it could be operated without a computer being connected, allowing more flexibility for the group and removing the need for a group member to always be present with the printer as it operated. The control panel consisted of a multi-line LCD display, an SD card slot and a selector dial. The display showed the status of the printer, and by using the selector knob allowed menus to be browsed. The menus allowed the printer to be operated without the need for a computer, with features such as calibration and axis movement being accessed through these.

The SD card slot was a useful feature that allowed GCode files to be loaded to the printer without having a computer connected. This gave the group flexibility to leave the printer operating without a group member being present with their laptop and allowed them to work on other tasks. The group purchased an SD card on which they stored the GCode files for the specimens to be printed at that time, then any group member could quickly select and start the printing process.

5.3.7 Enclosure

The group designed and built an enclosure for the printer in line with recommendations from the project supervisor and workshop manager. The enclosure served two purposes: to protect the printer from the workshop environment; and to prevent other workshop users from the heated and moving parts of the printer. The enclosure was manufactured from clear acrylic sheeting and aluminium strut profiles, and covered the four sides and the top of the printer. A hinged door was added to allow easy access to the print bed, and allowances made for the filament to feed in and the control panel to be accessed.

The group made use of the 3D printer to manufacture some of the components of the enclosure. This included a stand to hold the power supply in position, spacers to hold the acrylic sheets in place and mounts to hold the printer in the correct place relative to the door of the enclosure. Also designed and printed were aesthetic components: a knob for the hinged door and a cover for the control panel.

6. Printing Process

6.1 Overview

There are several factors to be considered when creating 3D printed components. Some of these are related to the hardware being utilised, while others result from the model creation and slicing processes. This section aims to provide an overview of the steps involved in creating and preparing a model, and preparing the printer to obtain optimal results. It will also address the problems that can be encountered, and identify possible solutions to overcome these.

6.2 Calibration

To obtain high-quality and reliable prints from any 3D printer, it is necessary to calibrate the printer. Calibration is required to ensure that all functions of the printer are set up correctly and to ensure that GCode files will be interpreted properly, to produce the desired output.

For this project, the printer used was purchased with pre-calibrated firmware, and so the calibration activities that were undertaken were in terms of hardware calibration. However, since it was a self-build kit, there were a number of points to note before undertaking calibration. The quality of the assembly is as important as the calibration in self-build versions, since the calibration steps are irrelevant if the printer is not assembled correctly. With respect to this, it is crucial to ensure that all bolts are tightened such that there is no movement of the parts relative to each other, for example the frame must be securely fixed to the base assembly. The belts must also be tightened so that there is no slack in the system. If there is slack present, then the movement of the stepper motor will not be directly correlated to the movement of the axis to which it is connected.

Once the hardware was assembled correctly, the printer could be calibrated. For this printer, there were three main stages of calibration undertaken:

- Levelling of x-axis relative to the z-axis;
- Levelling of the print bed, and;
- Calibrating the nozzle height above the print bed.

The importance of levelling and calibrating the printer is significant to achieving reliable and consistent prints as it can drastically affect the quality of the print. By

confirming that the above conditions are met, it is likely that good quality prints will be achieved. Failure to address these will lead to poor quality prints. Many of the calibration tasks, once completed, will require little further attention.

The first stage was to ensure that the x-axis was level and perpendicular relative to the z-axis, so that both sides of the x-axis rail are the same height above the z-axis stepper motors. This was achieved by lowering the x-axis to the lowest z-position possible and ensuring that the x-axis was resting on the couplings at both sides. When set correctly, the x-axis should be the same height above the zero point of the z-axis along its entire length. It is important to set this correctly, as the printer is extremely sensitive to variation in this plane, since it is the z-axis that controls the layer height. The layer heights can be as low as 0.1mm, and so even a slight variation can lead to a drastic reduction in the quality of the prints. Once this has been set, it should not need to be revisited unless a reduction in print quality is observed, however it can be worth confirming it is still correct if the printer is moved or altered in any way.

Levelling of the print bed ensures that the print surface is the same distance from the x-axis at all points in the x-y plane. This can be achieved by a number of methods, of varying complexity, but the most common is to move the extruder to the extremes of each corner of the print bed, and then ensuring that the nozzle sits the same distance above the surface at all corners by adjusting the spring and screw arrangement in each corner. Moving the nozzle to the corners can be achieved by controlling the printer via a USB interface (such as through the Pronterface² software), but in the case of the Prusa i3 this task is simplified thanks to its built-in plate levelling functionality. This function automatically moves the print head to each of the corners in turn, and then the centre to confirm the results. It was found that the use of a feeler gauge aided this procedure, since it was hard to judge the distances by the naked eye.

The final calibration stage is to set the nozzle height above the print surface. This is of supreme importance as it determines the thickness of the first layer, and since the first layer is critical to how well the print will be created, and particularly how well it will adhere to the print surface. For the Prusa i3, the base height is set by adjusting an end-stop screw on the z-axis that determined the height of the nozzle above the

² <http://www.pronterface.com/>

print bed when the end-stop sensor is triggered. To determine the correct height was largely trial and error, but once it had been set correctly a feeler gauge was used to determine the distance. A modification that the group made to this aspect of the printer was to replace the standard nut used for this end-stop screw with a locking nut, as it was noted that due to the vibration of the printer in operation there was a tendency for the accuracy to drift over time. The introduction of the locking nut reduced this effect considerably, but it was noted that this should be checked regularly as it has the potential to significantly hamper the print quality. More high-end printers, and indeed the updated version of the BQ Hephestos, are equipped with a feature that allows the printer to determine the correct height by means of a distance sensor on the extruder assembly.

6.3 Print Surface Adhesion

A major factor in obtaining high-quality and reliable prints from any 3D printer is ensuring that the piece is sufficiently adhered to the print surface, and the group experienced many problems with this particularly in the early stages. The printer was supplied with a thin glass plate to act as the print surface, however it was quickly found that this did not provide the necessary qualities to allow reliable printing with parts becoming unattached in a regular but unpredictable manner. Various trials were undertaken using different approaches to solve this issue, to varying degrees of success.

The group investigated using tape on the print surface, specifically masking tape and kapton tape, as these were widely recommended on 3D printing forums however adequate results were not achieved with these. The issue was complicated further by the fact that the tensile specimens being printed were long, thus particularly susceptible to warping. This effect was amplified by the environment in which the printer was being used, since the ambient temperature was low and so the parts were being cooled rapidly. Also investigated was using Perspex or acrylic sheeting as a print surface, and it was found that this offered good results if the surface was lightly sanded for parts with small base areas; however the problem of warping was still present on larger pieces. There was also the obvious drawback in these materials not being compatible with a heated print bed.

The group moved back to using the glass plate, but with the surface coated with layers of hairspray. A number of hairsprays were trialled, but it was found that the ones that provided the best results were those sold as being ‘extra hold’, and contained vinyl, acetate and co-polymer. The surface was coated with numerous thin layers of hairspray, created by spraying a fine mist of hairspray over the glass from around 30cm, allowing it to dry, then repeating. The results of this system gave very good printing performance, particularly when coupled with the heated bed.

6.4 Model

The model that is to be printed must be carefully prepared with consideration to the 3D printing process and its limitations to save iterations in the design when testing it. The following sections will summarise the general issues regarding model creation.

6.4.1 Model Orientation

When modelling, the direction of the printing process needs to be taken into account. Generally, leaving the biggest flat surface as the bottom layer will be most effective. The orientation might be subjected to changes due to model features such as bridges or overhanging edges being present, and also with consideration to the necessary strong axis of the part, particularly in component design, as the filament deposition direction is related to the strength, as seen in Figure 5.

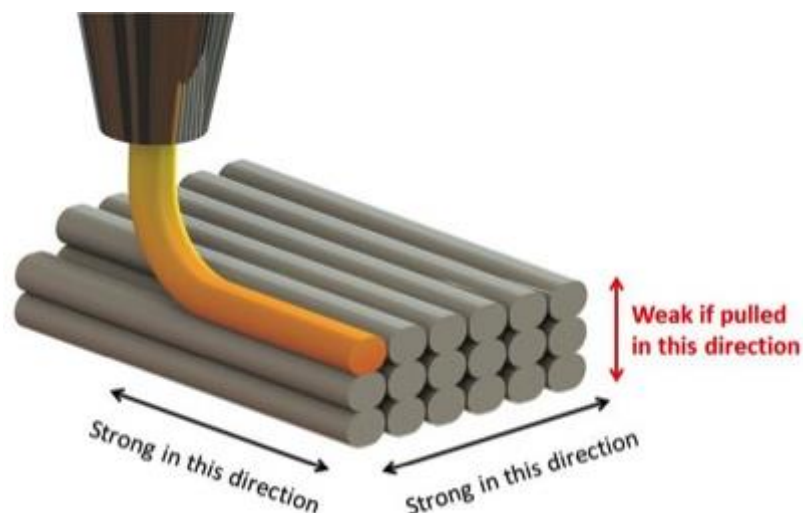

Figure 5: Schematic of Filament Deposition [21]

6.4.2 Overhanging Geometry

There is a limit on the step angle that can be printed properly without any trouble. In general, this angle should be taken to be 45° above horizontal. If exceeded, then the

effect seen in Figure 6 may be observed, where the overhanging layer is being laid on air rather than on top of previously deposited material. If overhanging geometry above this angle is required, then support material should be introduced, as can be seen in Figure 6.

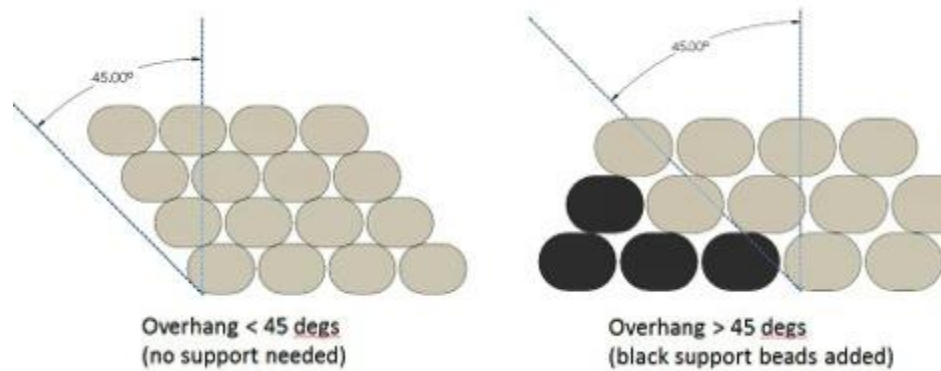

Figure 6: Schematic showing overhanging geometry [21]

6.4.3 Bridging

Bridging experiences similar issues to overhanging parts and they are often related. Bridging is the procedure when the printer deposits plastic in the air not onto the last layer to span across a gap between features of a component. It usually occurs when covering holes or a merging part of the model. Small bridges are usually covered without much trouble but when increasing the length, problems can be encountered as in Figure 7. Again, adding support material can mitigate against the problems of bridging large gaps.



Figure 7: Example of printed component with bridging [22]

6.5 Slicing

There are several software programs available to perform this task which use essentially the same methods but in some cases provide slightly different outcomes depending on the parameters specified for the GCode generation. In this project the program Cura was used due to its simple interface and the high quality prints obtained in the first print trials. Within the slicing programme, all the printing parameters can be changed depending on the result desired. The most prominent points associated with slicing are detailed in the following sections.

6.5.1 Overview

Since 3D printers build up geometry layer by layer by moving a print head and depositing material on each layer, the geometry to be created must be discretised into distinct layers. This process, commonly known as slicing when referring to 3D printing, takes a 3D geometry file and slices it into layers of a set thickness in line with a range of parameters that can be set.

Due to the nature of operation of a 3D printer, the nozzle moves to complete each layer before moving on to the next, and so the path to be taken by the nozzle must be determined by each layer and this is where the requirement to slice the geometry arises. The following sections will describe in detail the slicing process and the different parameters that can be set to affect the final printed structure.

To generate the 3D geometry there are a number of approaches that can be taken, but the most common is to create the model in a 3D CAD environment such as Solidworks, Creo or Autodesk Inventor. These allow complex geometries to be created, which can then be exported in a format that can be interpreted by the slicing software. The most commonly used format is to use an STL file, which represents the 3D surface geometry as a triangular representation by breaking the surface down into a series of small triangles [3]. The export options in the used 3D modeller software used may affect the quality of the STL model since it is made of triangles that make up the surface of the model, if the size of said triangles is too large, rounded features can be severely roughened.

Once the STL model is loaded on to the slicer program, Cura in this case, and the parameters set to the required values, the printer head path can be checked within the

software to check for any undesired outcomes of the GCode. In Cura this can be checked in the preview window by selecting the layer display option. Here, infill, wall perimeter and empty travel can be distinguished (yellow, red and green, and thin blue respectively) as seen in Figure 8. If unsatisfactory results are observed, the parameters can be altered to give the desired result.

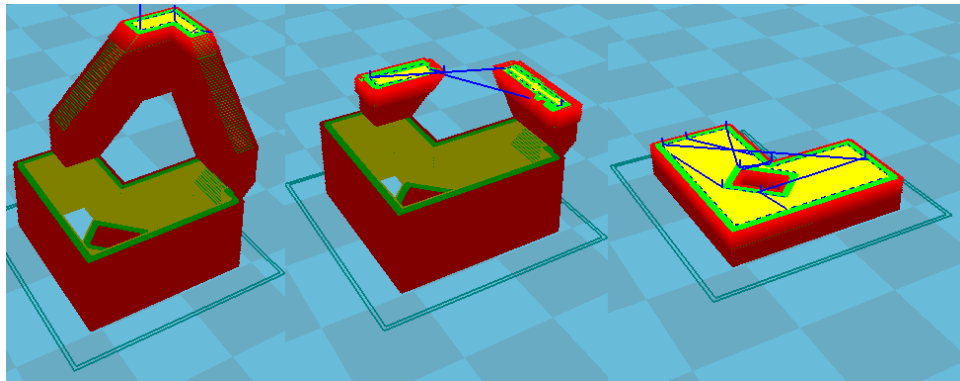

Figure 8: Slicing preview of component in Cura

6.5.2 Layer Thickness

In 3D printing, the layer height can be thought of as the printing resolution, with a smaller layer height meaning that geometry will be built up in more layers, hence allowing geometry to be created more accurately. This is particularly notable when curved surfaces are being created, since if the layer height is larger, the surface may not be smooth and may have a stepped appearance. The layer height has a significant effect on the time taken for the print to complete, and so it may not be beneficial to print at a high resolution.

The layer thickness parameter defines the thickness of each layer, and is commonly between 0.1mm (high resolution) and 0.3mm (low resolution). In all cases, the layer thickness should never exceed the nozzle diameter. For the printer in this instance, the nozzle is 0.4mm and so a layer thickness in excess of this would not be recommended. The layer thickness affects the roughness of the outer surface of the printed model, with a smaller layer thickness giving a better surface finish, as seen in Figure 9.

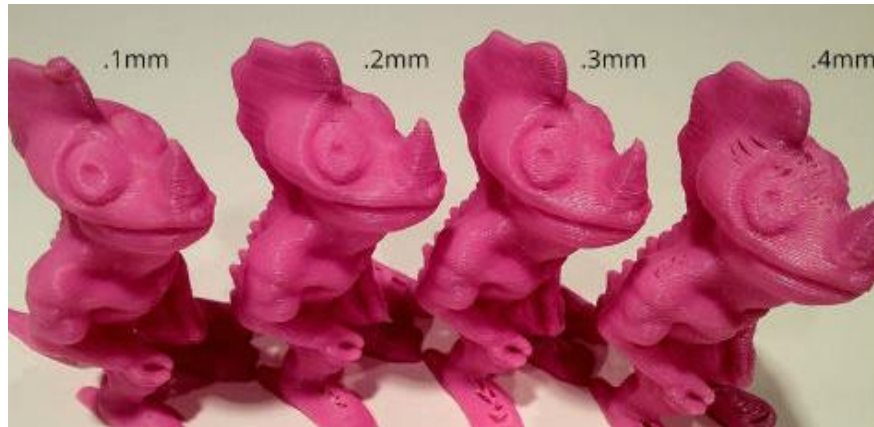

Figure 9: Example of the effect of changing layer height on complex geometry [23]

6.5.3 Infill percentage and pattern

The infill percentage is the percentage of the internal structure that is filled with material. An infill percentage of 100% will give a solid part, and 0% will give a hollow part with only the outer shell. This parameter does not affect the perimeter or walls, only the internal space. At infills between these extremes, the space is filled with an internal structure generated by the slicer software, the pattern of which can be altered in Slic3r, but not in Cura. The default in Cura is a square cross infill, but this can be changed in Slic3r to a range of patterns, such as a honeycomb.

In Figure 10 the different infill patterns at varying densities can be seen. From left to right: 20%, 40%, 60%, 80%; and from top to bottom: honeycomb, concentric, line, rectilinear, Hilbert curve, Archimedean chords, octagram spiral [4].

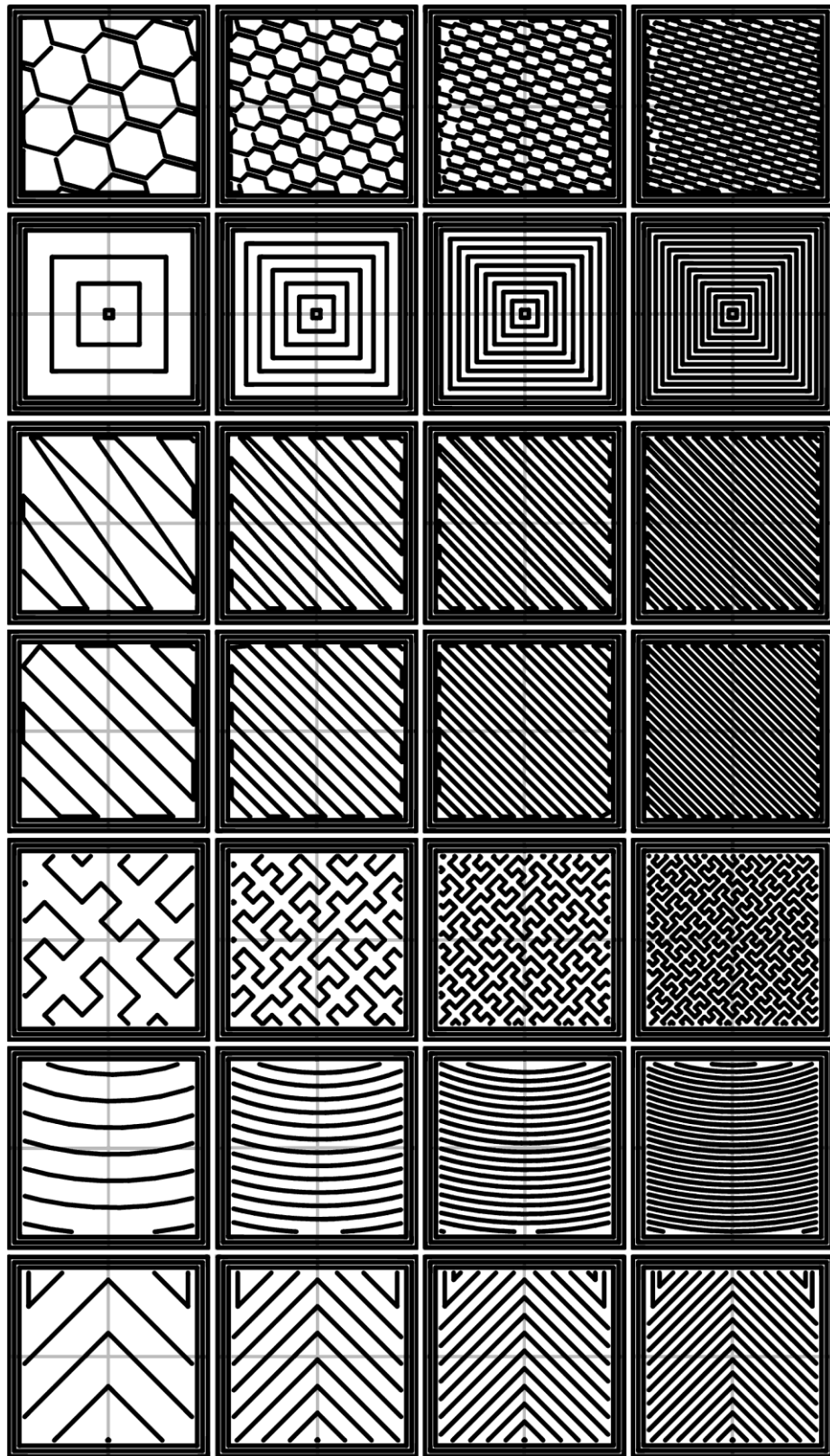

Figure 10: Examples of Infill Patterns [4]

6.5.4 Wall thickness

The wall thickness defines the number of passes that are performed to create the perimeter of each layer. It is related to the nozzle diameter and should be a multiple of this diameter to obtain optimum results. For instance, if a 0.4mm nozzle is being used, then the wall thickness should be 0.4mm (one pass, not recommended), 0.8mm (two passes) and so on. The effect of changing these is that the amount of hollow space inside the structure will be altered, and hence the amount of the infill pattern that can be created will be different. The wall thickness will have a slight effect on the appearance of the printed part if the walls are very thin as holes may occur, so a perimeter of at least twice the nozzle diameter is recommended as in Figure 11.



Figure 11: Schematic showing different wall thicknesses [21]

6.5.5 Bottom and Top Thickness

This parameter defines the thickness of the bottom and top layers, in mm. This should be a multiple of the layer thickness being used, with the multiplying factor representing the number of solid layers used to form the base, and to close the part at the top. To ensure a good surface finish, at least two layers should be used, and commonly three layers will be used. The bottom and top thickness should be selected with consideration made to the wall thickness being used, so that the shell of the part is consistent in all directions.

6.5.6 Additional Features

The slicing software allows a large number of other features to be altered that can allow the printing performance to be tweaked for specific applications. The most useful of these is the automatic generation of support material for overhanging geometry. Also it was found for component printing that the ability to generate a raft

or brim on the bottom layer was useful in improving the adhesion to the bed. Other features regarding the flow parameters, such as flow rate and travel speed of the print head can also be altered, however they were not used in this project. The features of the slicing programmes are extensively documented in the manuals for the programme [4].

7. Testing

7.1 Purpose

7.1.1 Mechanical Properties and Performance

The reaction of a material to a mechanical stress is defined as the mechanical behaviour of a part. Deformation caused by the applied force to a component highly depends on the direction of the applied force as well as the component's mechanical properties and the size of its geometry.

The focus on this paper has been to present the mechanical behaviour in terms of properties and performance of 3D printed parts manufactured when different user controlled printing and slicing parameters are used. In addition, the use of natural fibre as reinforcement material to polymer of raw materials was also presented. The mechanical properties of the parts will covered the relationship between deposition raster orientations and layer heights to tensile strength, strain and modulus. Furthermore, the mechanical performance of the parts covered its printing time and cost to manufacture each parts.

7.1.2 Different Slicing Parameters

A study made by Sood et al. [5] stated that parts fabricated by FDM process when subjected to tensile, flexural, impact and deflection test are influenced by four important parameters; raster orientation, layer height, raster width and air gap. Bellini et al. [6] shows that LM techniques used in FDM fabricate orthotropic parts whereby the mechanical properties and performance of the parts are affected by the raster orientation and individual layer built. Similar study by Es Said et al. [7] explained this situation is related to the alignment of polymer molecules along the direction of deposition which affects the tensile, flexural and impact strength. Both literatures pointed out that this phenomenon is due to weak interlayer bonding and high porosity which reduces the load bearing area. Ang et al. [8] then mentioned the most significant process parameter in affecting the porosity is the existence of air gap which significantly affected the tensile strength of FDM parts and has been proven through experimental design and analysis by Ahn et al. [9]. Moreover, Sun et al. [10] identified that the arise of voids or air gaps from insufficient filling of material within the perimeter-raster or raster-raster of FDM parts were the cause of

the processing conditions which may reduce quality and effective cross sectional area [9]. Meanwhile, Lee et al. [11] have concluded that the layer height, raster angle and air gap also influence the elastic performance of FDM products.

7.2 Experimental Work

This section described the materials, equipment and conditions used in the production and mechanical characterization of the samples in detail.

7.2.1 Materials and Filament Extrusion

The three materials used for the samples throughout this study were made from two of the most commercially available materials for 3D printing technology: pure 100% Poly-Lactic Acid (PLA) from BQ, Proto-pasta carbon fibre reinforced PLA, a PLA reinforced with 15% in weight of carbon fibre (CFPLA) and OO-Kuma CF0 Acrylonitrile butadiene styrene (ABS) reinforced with 12% in weight of carbon fibre (CFABS). Their main characteristics are listed in Table 6.

	BQ-PLA	PP-CFPLA	OOKU-CFABS
Diameter (mm)	1.75	1.75	1.75
Density (g/cm³)	1.24	1.3	1.08
% wt. carbon fibres	-	15	12
Tensile yield strength (MPa)			52
Processing temperature (°C)			

Table 6: Manufacturer stated properties of filament materials

Polylactic acid (PLA) polymer is a bio-degradable plastic derived from plant-based resources and has become a well-known polymer in FDM industries. PLA appeared to have a lower coefficient thermal expansion, thus reduces the effects of warping, a wide range of available colours as well as translucencies and glossy feel which often attract those who print for display or small household uses. Furthermore, PLA is known to be stronger than ABS however being more brittle.

Acrylic butadiene styrene (ABS) is a carbon chain polymer made by dissolving butadiene-styrene copolymer in a mixture of acrylonitrile and styrene monomers which then undergo monomer polymerization with free-radical initiators. ABS is known to have a relatively good strength, strain and high temperature resistance which make it a preferable polymer for many engineering application.

7.3 Production of Samples

7.3.1 Printing parameters

A strategic printing approach was initially performed to determine the optimal printing conditions with the materials. An organized strategy was pursued, starting with the production of thin sample perimeter (single filament thick) in order to determine the wall thickness, the extruder temperature and speed, and the conditions leading to a good printed part - heating bed adhesion. PLA and ABS both shows a high degree of shrinkage cooling (due to its semi-crystalline property), which led to warping and decoupling from the printer's bed. In order to obtain satisfactory quality of printing conditions, tens of printings were performed varying the nozzle temperature and the heating bed material and temperature. Table 7 sets out the optimal conditions for printing with the three materials.

In addition, a few details are worth being highlighted to the above printing conditions, particularly regarding the printing surface of the bed. Both PLA and ABS showed low adhesion to the glass surfaces which comes with the printer kit. Therefore, some methods have been taken to overcome the problem which includes using different type of tapes on the glass and replacing the glass with a pre-processed layer of acrylic where its surface is scrubbed with a sandpaper. Finally, the solution found to improve the adhesion of the printing parts to the bed was to use layers of chemical compatible hairspray. The contrast between objects printed with optimal conditions corresponding with the non-optimal conditions was significant. Some parameters such as nozzle extrusion speed, number and thickness of perimeter walls and number and thickness of roof(s)/floor(s) were kept constant to ensure the specimens are as similar as possible. However, while all specimens were created from the same .STL file, the extruder and bed temperature values were chosen based on the recommended values stated by each filament's suppliers for which it produces the best print quality.

Material	PLA	CFPLA	CFABS
Bed	Heated	Heated	Heated
Bed temperature (°C)	30	30	85
Extruder temperature (°C)	220	220	235
Extrusion Speed (mm/min)	60	60	60
No. of perimeters, thickness (mm)	2, 0.8	2,0.8	2,0.8
Floor/roof thickness (mm)	0.3	0.3	0.3

Table 7: Optimal process parameters for tensile sample printing

7.3.2 Preparation of Tensile Specimens

The same part (tensile test specimen) was printed with the defined optimal conditions for analysis and benchmarking in regard to the mechanical properties. As there is no publication on standards produced for rapid prototyping (RP) parts, the British Standard ISO 527 (BS ISO 527) [12], which is the standard for moulded plastic parts, was used as guideline for the tensile testing procedure to ensure comparable data. The tensile test samples were prepared according to the geometry and dimensions detailed in the standard as shown in Figure 12 and Table 8 below.

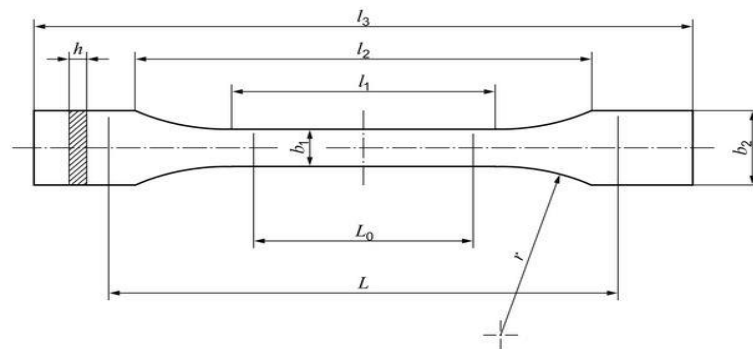

Figure 12: Diagram of standard tensile test specimen as per BS ISO 527-2

Dimension	Description	Dimension (mm)
l_3	Overall length	≥ 170
l_1	Length of narrow parallel-sided portion	80 ± 0.5
l_2	Distance between broad parallel sided portions	109.3 ± 3.2
b_2	Width at ends	20 ± 0.2
b_1	Width at narrow portion	10 ± 0.2
h	Nominal thickness	4 ± 0.2
L_0	Gauge length	50 ± 0.5

Table 8: Critical dimensions of standard tensile test specimen

The tensile test sample was designed using a standard 3D CAD program before being exported in .STL format to the slicing software. A free and open source slicing program, Cura was used throughout the project. This software was used to control the user defined slicing parameters and produce commands in the form of GCode for the printer. All the specimens were created from the same .STL file.

7.3.2.1 3D Printing

At the 3D printing stage, the specimens were printed with the same infill percentage but with different deposition orientation and layer height. The infill percentage is one of the key parameters in FDM process as lower percentage infill practically contributes to a much lower material extrusion thus less printing time. A study led by Carneiro et al. [13] proved that the higher infill degree made a strong impact with 250% higher in both modulus and strength when comparing a sample with 100% and 20% infill percentage samples. Furthermore, a study led by Baich et al. [14] on printing parameters and production cost-time relation also showed that a longer printing time and more material consumption for samples produced with higher infill percentage.

As the interest parameters to be looked at in this study are the effect of raster orientation and layer heights on the mechanical properties and performance of the parts, a 100% of infill degree samples were chosen as standard to evaluate the other two parameters in a balanced manner. Then 0.2mm layer height and a diagonal deposition pattern were chosen to compare between the three chosen materials.

7.3.2.2 Raster Orientation

The first altered slicing parameter in this study focuses on the effect of raster orientation of the printed specimens. The raster orientation is divided into two types which are diagonal ($\pm 45^\circ$) and linear ($0^\circ/90^\circ$) as in Figure 13. For both orientations, the perimeter of the layer is formed by a contour tool-path at first, and then the interior is filled with a raster (back and forth) tool-path at an angle of 45° to the y-axis. Alternating layers are filled with a raster direction at 90° to one another as Figure 14.

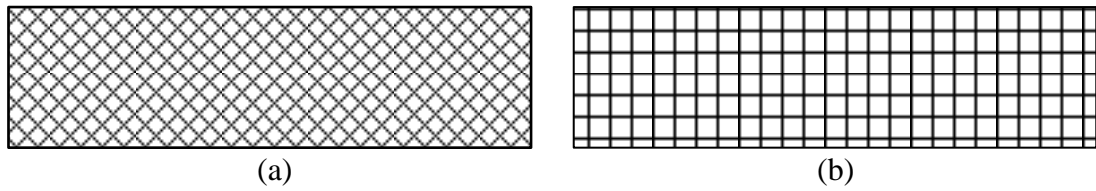

Figure 13: (a) Diagonal infill pattern (b) Linear infill pattern

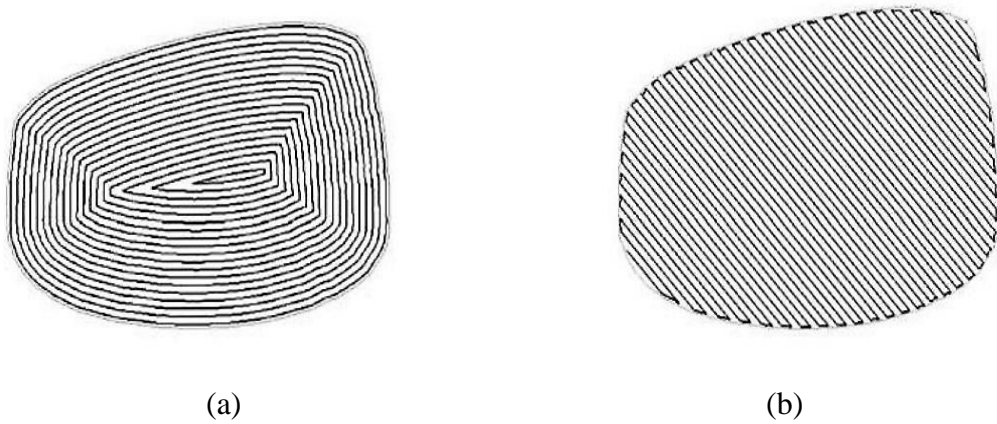

Figure 14: Different tool-path configuration (a) contour tool-path (b) raster tool-path [6]

The diagonal specimen as per BS ISO527 specification was built in the direction x-y as presented in Figure 15 to produce a diagonal pattern toolpath which can be seen in Figure 16.

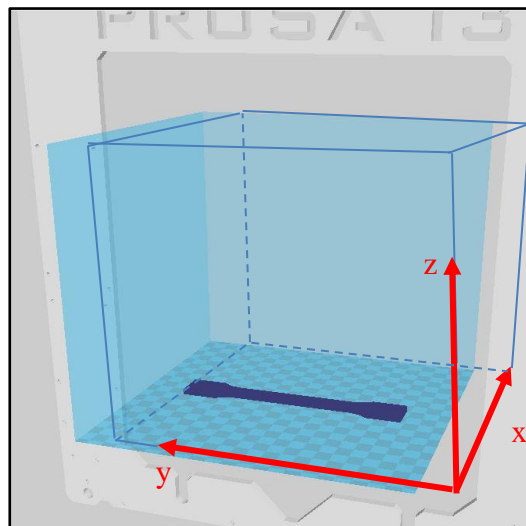

Figure 15: Build orientation of diagonal pattern tensile specimen within print volume

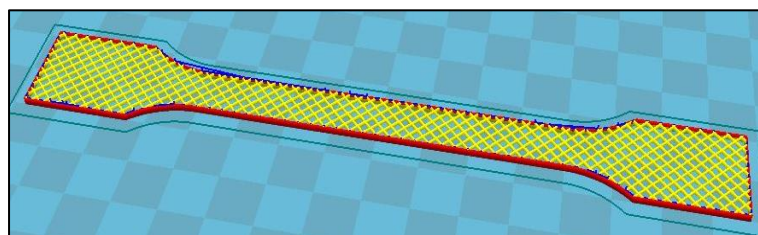

Figure 16: Layer preview of diagonal infill tensile specimen

The slicing software Cura offers its user a medium amount of setting. Per say, in default, Cura sliced the material with diagonal pattern back and forth at an angle of $\pm 45^\circ$ to the x-axis only. Therefore, certain adjustments were made by rotating the sample printing direction $+45^\circ$ to the x-y plane as in Figure 17. This indirectly produced samples with linear raster orientation as shown in Figure 18.

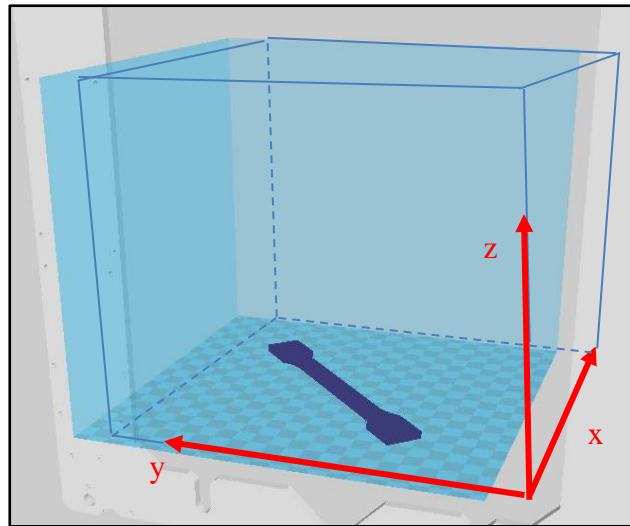

Figure 17: Build orientation of linear pattern tensile specimen within print volume

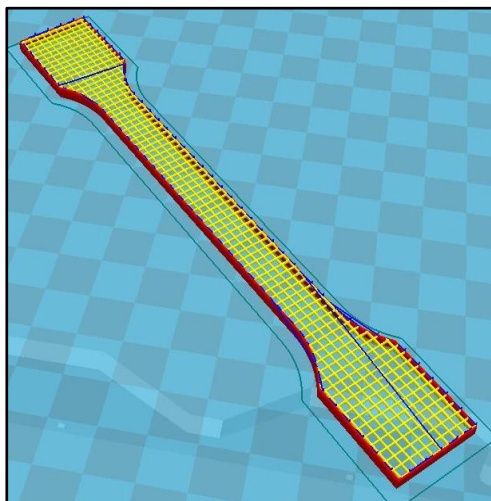

Figure 18: Layer preview of linear infill tensile specimen

7.3.2.3 Layer Heights

The layer height (as shown in Figure 19) is primarily responsible for the geometrical resolution of the printed parts. In other words, lower layer height produced better quality of printed parts and is directly related to the nozzle diameter. In this study,

the samples with each raster orientations are divided into 0.1mm, 0.2mm and 0.3mm layer heights.

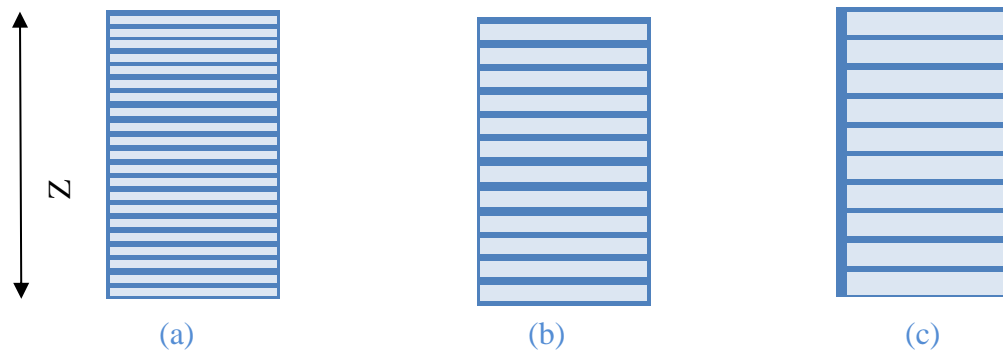

Figure 19: Schematic of changing layer height

7.3.2.4 Conditioning

During this experiment, no intentional samples conditioning was performed. This is mainly due to uncontrollable environmental conditions during printing and storage and the results of geometry variability of the samples printed. Thus, it diverged from BS ISO 527 standard which required samples to be condition at certain amount of time in room temperature at specific temperature before testing. However, the advantage of determining a realistic mechanical property values which users might encounter could be achieved.

7.3.2.5 Air Gaps

Certain slicing programs were made capable to alter the gap size between raster infill pattern and the gap size between raster to perimeter contour. In fact, some publicized papers had found that the gap size is one of the most important factor contributing to the tensile strength, thus affecting the mechanical properties of a part [15] [16]. One study shown that for all directions of orientation, negative raster air gap produced the best results [17]. In contrary, Sood et al. observed as the air gap increases, flow of materials are better towards adjacent material, thus increases bonding surfaces, hence improving strength [5]. However, in this paper, these effects were not studied. Furthermore, one should realise that while all specimens were printed solid with infill percentage of 100%, the exact negative or positive gaps might vary between specimens of same material, raster orientation and layer height setting. Figure 20 shows a microscope image obtained through the optical microscope showing the air gaps present in a standard printed specimen. Figure 21 shows a schematic explaining how the air gaps may appear between rasters.

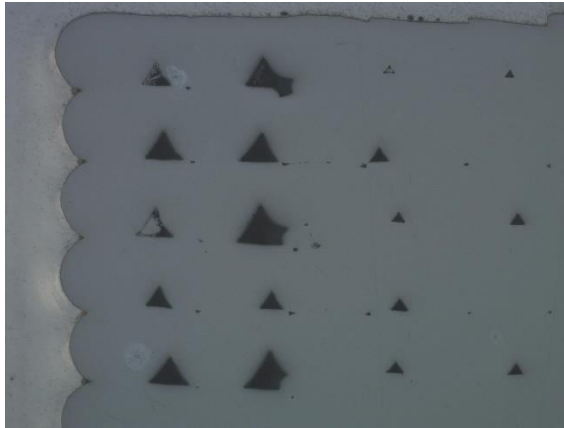

Figure 20: Optical microscope analysis showing air gaps within printed specimen

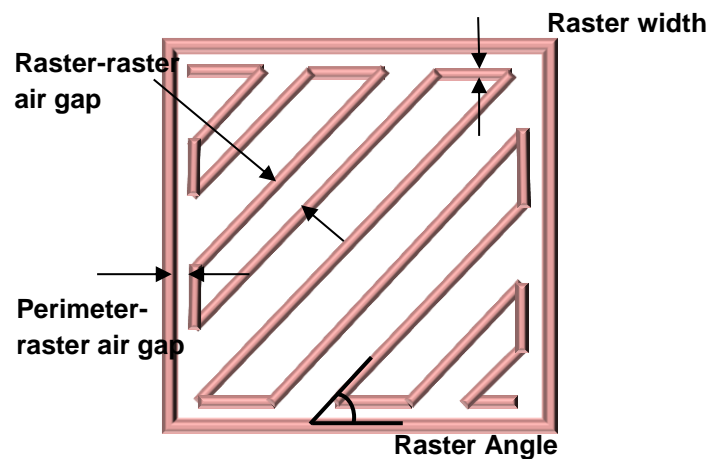

Figure 21: Schematic of tool-path parameters

7.3.3 Filament Sample Preparation

The set up to test bulk filaments (Figure 22) was adapted from a publicized paper by Bellini et al. [6].

For the bulk filament preparation, the specimen was glued on a thick (approximately 4mm) corrugated cardboard frame with dimensions specified in the figure. The frame main function is to provide a larger surface area for gripping and the samples were attached to the frame with epoxy. The epoxy was first filled in two channels of 25mm long and three filament diameters wide before the filament was laid down (with 10mm overhang the frame) in the channels. The two channels were made by cutting through the top layer of the cardboard but leaving the corrugated section intact. In order to indicate any slipping of filament during testing, the length of filament overhang the frame was compared pre and after the pulling phase. The channels were then covered and the epoxy was let to dry overnight. Once the epoxy

has hardened, the frame was cut symmetrically (to avoid unnecessary effect of the cardboard) and carefully placed on the Instron machine by gripping at the covers.

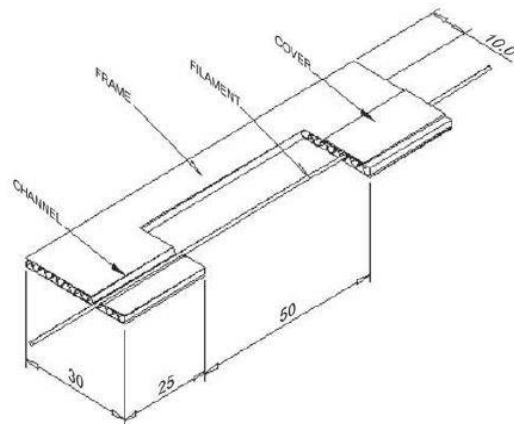

Figure 22: Filament Sample Preparation method [6]



Figure 23: Filament sample mounted in Instron tensile testing machine

7.4 Tensile Testing

The tensile test was performed on a universal Instron 5969 Dual Column Table-top Testing system controlled using the Bluehill software on a Windows PC. The load was measured to be 50kN load cell and specimens were loaded until they broke. The test was also performed according to BS ISO 527 at temperature and relative humidity specified in the standard. Strain was measured automatically by the video extensometer (calibrated to the gauge length of the specimen) attached to the frame of the system. Each test was conducted with a crosshead speed of 1mm/min. The

data points in Excel format regarding tensile stress, tensile strain and tensile modulus were obtained automatically from the Bluehill software. Additional linear regression method was also performed in obtaining tensile modulus on the stress-strain diagram with equation (1) (Hooke's Law) in the strain interval between $\varepsilon_1 = 0.05\%$ and $\varepsilon_2 = 0.25\%$ (Figure 24: Linear regression to obtain tensile modulus). Five specimens were tested for each sample set for a given group of printing parameter settings in Table 9, Table 10 and Table 11.

$$E = \frac{\Delta\sigma}{\Delta\varepsilon} \quad (1)$$

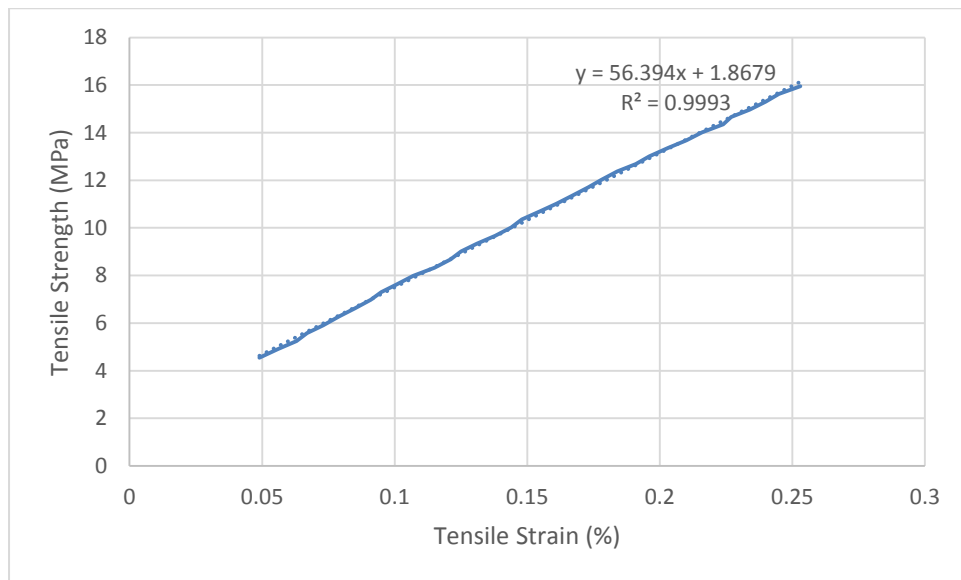

Figure 24: Linear regression to obtain tensile modulus

7.4.1 Schedule of Test Combinations

Supplier	Material Type	Infill (%)	Infill Pattern	Orientation angle (°)	Layer Height (mm)	Abbreviation
BQ	PLA	100	Linear	0/90	0.1	BQ-PLA_L_1
				0/90	0.2	BQ-PLA_L_2
				0/90	0.3	BQ-PLA_L_3
			Diagonal	+45/-45	0.1	BQ-PLA_D_1
				+45/-45	0.2	BQ-PLA_D_2
				+45/-45	0.3	BQ-PLA_D_3

Table 9: BQ PLA filament test schedule

Supplier	Material Type	Infill (%)	Infill Pattern	Orientation angle (°)	Layer Height (mm)	Abbreviation
Proto Pasta	CFPLA	100	Linear	0/90	0.1	PP-CFPLA_L_1
				0/90	0.2	PP-CFPLA_L_2
				0/90	0.3	PP-CFPLA_L_3
			Diagonal	+45/-45	0.1	PP-CFPLA_D_1
				+45/-45	0.2	PP-CFPLA_D_2
				+45/-45	0.3	PP-CFPLA_D_3

Table 10: ProtoPasta Carbon Fibre PLA filament test schedule

Supplier	Material Type	Infill (%)	Infill Pattern	Orientation angle (°)	Layer Height (mm)	Abbreviation
OO-Kuma	CFABS	100	Diagonal	+45°/-45°	0.2	OKU-CFABS_D_2

Table 11: OO-Kuma Carbon Fibre ABS filament test schedule

7.5 Results and Discussions

The data obtained includes specimens that broke outside of the marked gauge length (as in Figure 25) as a result of assumed stress concentrations in the region where geometry is changing. This data displayed a significant maximum stress before failure, so no conclusion could be made regarding specimen tensile strain. Furthermore, it must be added that possible defects might have occurred during printing which resulted in a large number of specimens failing prematurely. As the filament material is extruded from the nozzle, it cools down from glass transition temperature to surrounding temperature causing inner stresses to be developed due to uneven deposition speed which leads to defects. These defects include:

- Intra-laminar defects, due to excess material dropped onto layer from the extruder nozzle;
- Inter-laminar defects, due to air gaps created by under or over fill between the raster.

Defects can be observed in the form of cracking, de-lamination or part fabrication failure.



Figure 25: Example of a specimen that has broken outside of the gauge length

The stress-strain curves produced by the Bluehill software are shown in Figure 26, Figure 27 and Figure 28, and indicate the brittle nature of failure for all the materials, layer heights and layer orientation.

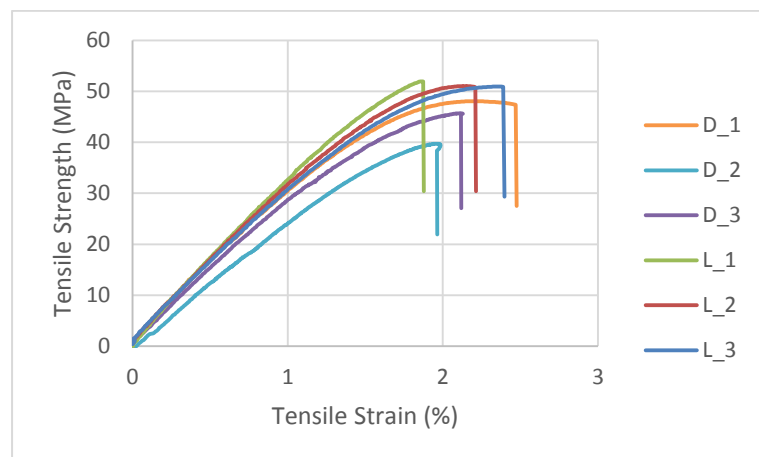

Figure 26: Stress-strain curve of PLA samples. Legend:[orientation_layer height]

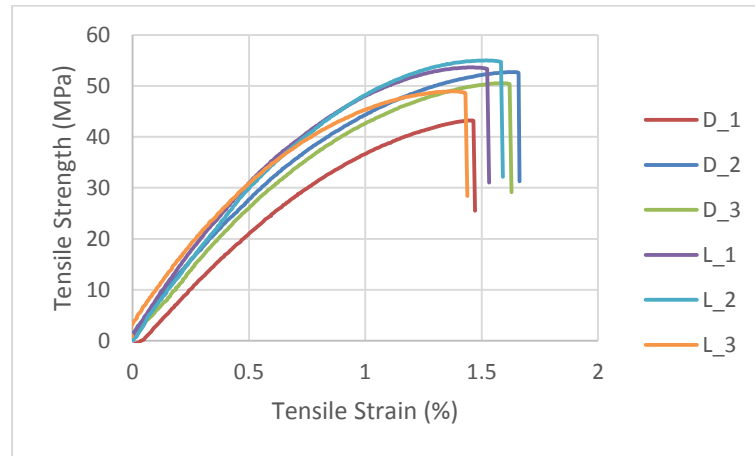

Figure 27: Stress-strain curve of CFPLA samples. Legend:[orientation_layer height]

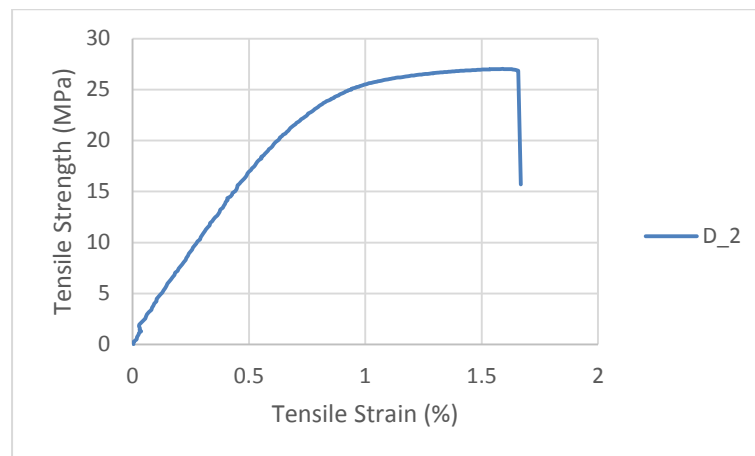

Figure 28: Stress-strain curve of ABS samples. Legend:[orientation_layer height]

7.5.1 Filament

Both PLA and CFPLA filaments were set up as mentioned in section 7.3.3 and tested on the tensile machine. More than five specimens were tested and load was increased until the filament broke.

Material	Ave. Tensile Strength (MPa)	Ave. Tensile strain (%)	Ave. Tensile Modulus (GPa)
PLA	48.97	3.43	2.47
CFPLA	51.24	2.71	3.83

Table 12: Results of filament testing

Table 12 showed the average value of tensile strength, strain and modulus for PLA and CFPLA filaments. It must be added that most of the specimens failed during testing whereby three factors contributed to this problem are identified. Firstly, the

filaments tended to break at the end where the epoxy used to attach the filament to the frame, as per Figure 29. Secondly, the gripping pressure applied to the frame was too high which made the filament fractured within the frame end and thirdly, the gripping pressure at the frame end was too low which made the filament slipped during testing. Furthermore, the data displayed in the table accounted for three of PLA filaments and only on CFPLA filament. However, from the successfully tested specimens, it was observed that the tensile strength and modulus of CFPLA is higher than PLA as expected. This can be explained by the presence of carbon fibre within the filament contributed to its strength as well as its stiffness. Meanwhile, the tensile strain in PLA filament is higher than CFPLA as its being more ductile compared to the CFPLA filament.

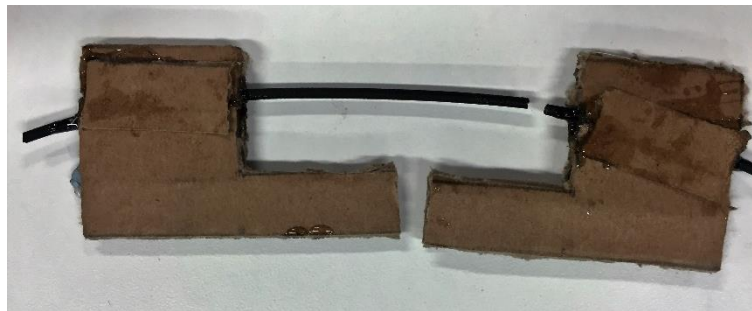

Figure 29: Example of filament failing at epoxy end

7.5.2 Raster Orientation

The tensile test results of the PLA and CFPLA samples built with different orientations: linearly ($0/90^\circ$) and diagonally ($45/-45^\circ$) are shown in Table 13. A set of five samples were tested and the average values of the tensile strength and modulus were calculated. The data obtained from the test showed variations between different sets of specimens for both PLA and CFPLA.

For PLA specimens, the tensile strength and elastic modulus showed a significant 20% and 14.5% difference in average values orientation based. Whereby, the specimens printed with a linear raster orientation had a much higher value of 52.64 MPa tensile strength and 3.39 GPa elastic modulus in average.

The CFPLA specimens showed a smaller difference in average values with only by 1.24 MPa, or 2.5% orientation based in terms of tensile strength. However, the average elastic modulus showed a large distinction by 1.1 GPa or 21%.

Material	Raster Orientation (°)	Layer Height (mm)	Tensile Strength (MPa)	Ave. Tensile Strength (MPa)	Tensile Modulus (GPa)	Ave. Tensile Modulus (GPa)
PLA	0/90 (linear)	0.1	54.90	52.64	3.63	3.39
		0.2	53.40		3.34	
		0.3	49.63		3.21	
	45/-45 (diagonal)	0.1	46.52	43.91	3.04	2.96
		0.2	41.72		2.85	
		0.3	43.49		3.00	
CFPLA	0/90 (linear)	0.1	53.25	50.63	6.59	6.34
		0.2	51.17		6.11	
		0.3	47.48		6.31	
	45/-45 (diagonal)	0.1	46.07	49.39	5.07	5.24
		0.2	53.29		5.52	
		0.3	48.81		5.12	

Table 13: Results of tensile testing of specimens in terms of raster orientation

In general, it can be observed that linear pattern structure indicates a higher value of maximum tensile stress and modulus compared to the diagonal pattern structure. This phenomenon can be explained by magnifying the fractures surface of the specimens with scanning electron microscope (SEM) as in Figure 30 and similar results are observed by Fatimatuzahraa et al. [18]. The authors explained that the mechanical behaviour the linear structure has a higher mechanical property because of the tensile force applied to the samples was supported by the roads which are parallel to the directions of the samples being pulled. This gives higher tensile strength and elastic modulus properties of the sample. On the other hand, with the diagonal samples, although the structure is denser with less air gaps, the bonding between each layer is weaker as a result of non-parallel road formation to the applied tensile force.

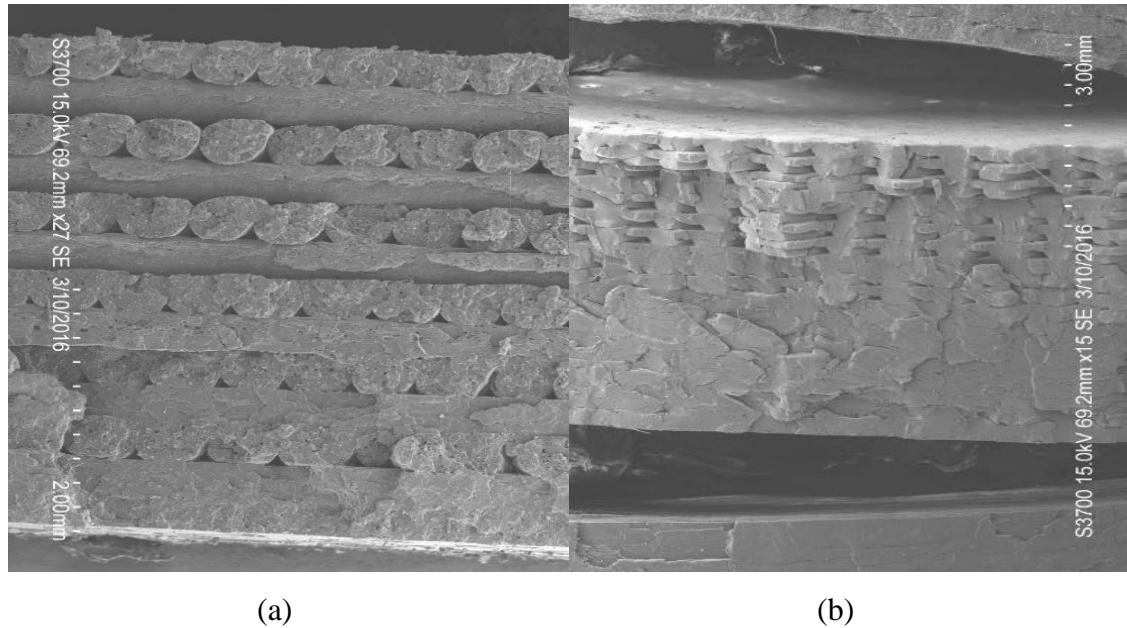

Figure 30: Examples of fracture surface viewed under Scanning Electron Microscope (a) linear (b) diagonal

7.5.3 Layer Heights

Material	Layer Height (mm)	Raster Orientation (°)	Tensile Strength (MPa)	Ave. Tensile Strength (MPa)	Tensile modulus (GPa)	Ave. Tensile Modulus (GPa)
PLA	0.1	45/-45	46.52	50.71	3.04	3.34
		0/90	54.90		3.63	
	0.2	45/-45	41.72	47.56	2.85	3.10
		0/90	53.40		3.34	
	0.3	45/-45	43.49	46.56	3.00	3.11
		0/90	49.63		3.21	
CFPLA	0.1	45/-45	46.07	49.66	5.07	5.83
		0/90	53.25		6.59	
	0.2	45/-45	53.29	52.23	5.52	5.82
		0/90	51.17		6.11	
	0.3	45/-45	48.81	48.15	5.12	5.72
		0/90	47.48		6.31	

Table 14: Results of tensile testing in terms of layer height

The effect of layer height was determined comparing samples printed with layer height 0.10, 0.2 and 0.3mm for both raster orientations and materials. As can be observed in Figure 31 and Figure 32, the outcome of this parameter is more noticeable in the linear direction for both materials. For diagonally printed specimens, both PLA and CFPLA samples shows inconsistent results. The highest value of tensile strength is observed at 0.1mm layer height and the lowest is at

0.2mm layer height for PLA. On the other hand, the highest tensile strength is observed at 0.2mm layer height and the lowest is at 0.1mm layer height for CFPLA. Meanwhile, for linearly printed PLA and CFPLA, the samples produced with the lower thickness show a higher tensile strength.

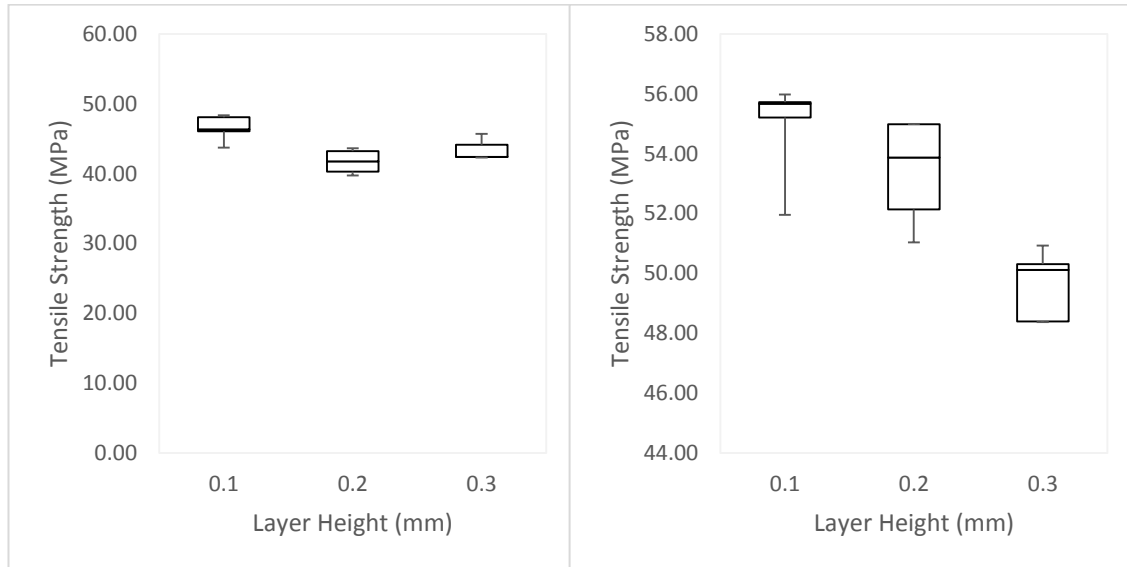

BQ-PLA-D

BQ-PLA-L

Figure 31: Tensile testing results from BQ PLA specimens

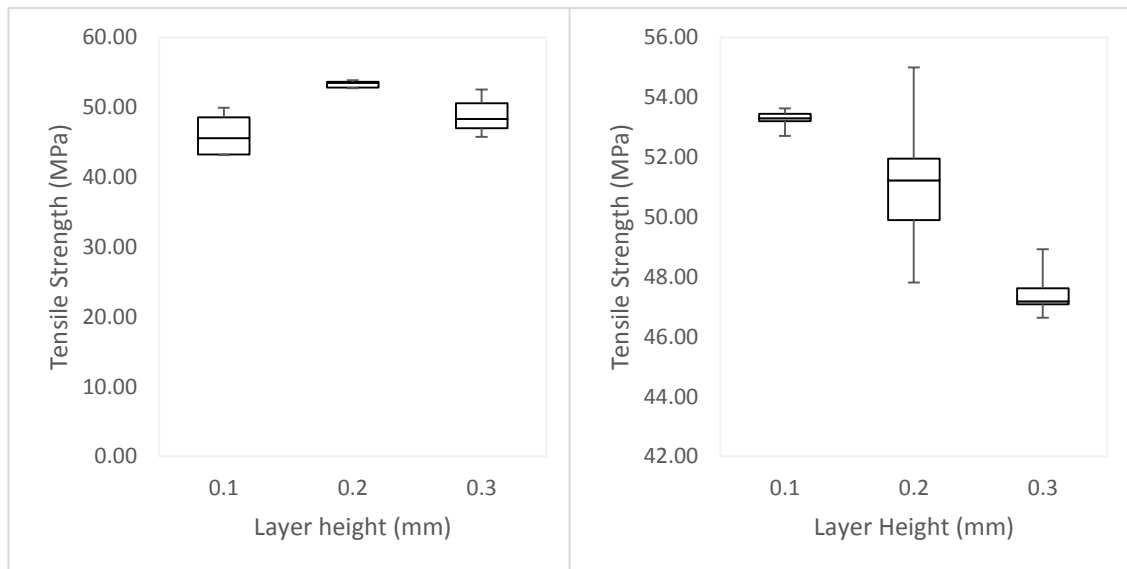

PP-CFPLA-D

PP-CFPLA-L

Figure 32: Tensile testing results from ProtoPasta Carbon Fibre PLA specimens

The results regarding effect of layer height obtained from the experiment were contrary to the work by Sood et al [5] and Carneiro et al [13] whereby in their

experiments, tensile strength decreases as layer heights decreases. This was related to the weak interlayer bonding due to distortion created by the high temperature gradient towards the bottom layer. In other words, as the layer heights decreases, more number of layers will be required and distortion effect is maximized and hence, strength decreases.

7.5.4 Performance and Quality

7.5.4.1 Dimensional Accuracy

Material	Layer Height (mm)	Raster orientation (°)	Ave. Actual width (mm)	Ave. Actual Thickness (mm)
BQ PLA	0.1	45/-45	10.74	3.81
		0/90	10.44	3.95
	0.2	45/-45	10.22	4.12
		0/90	10.42	4.23
	0.3	45/-45	10.43	3.89
		0/90	10.40	3.71

Table 15: Measured dimensions of BQ PLA specimens

Material	Layer Height (mm)	Raster orientation (°)	Ave. Actual width (mm)	Ave. Actual Thickness (mm)
PP CFPLA	0.1	45/-45	10.59	3.91
		0/90	10.37	3.83
	0.2	45/-45	10.63	3.80
		0/90	10.64	3.94
	0.3	45/-45	10.58	3.79
		0/90	10.66	3.71

Table 16: Measured dimensions of ProtoPasta Carbon Fibre PLA specimens

Table 15 and Table 16 above display the average actual width and thickness of five specimens per printed parameter. As can be seen, most samples actual width and thickness are over the tolerance of 10 ± 0.2 mm for width at the narrow portion and 4 ± 0.2 mm for nominal thickness as mentioned in the standard.

7.5.4.2 Printing Time

Material	Layer Height (mm)	Raster orientation (°)	Ave. Print time (min)	Material	Layer Height (mm)	Raster orientation (°)	Ave. Print time (min)
BQ PLA	0.1	45/-45	88	PP CFPLA	0.1	45/-45	87
		0/90	87			0/90	87
	0.2	45/-45	50		0.2	45/-45	48
		0/90	49			0/90	49
	0.3	45/-45	35		0.3	45/-45	34
		0/90	34			0/90	34

Table 17: Tensile specimen printing times

From Table 17, for both PLA and CFPLA specimens, the print time needed to print 0.1mm layer height is in range of 87-88 minutes, 48-50 minutes for 0.2mm layer height and 34-35 minutes for 0.3mm layer height. In general, time taken to print the same part increases as the layer height parameter decreases. This is due to more layers are needed for a lower layer height, thus higher number of extrusion cycles, compare to a higher layer height to print the same volume of tensile test specimen. It can be seen that different raster orientation didn't bring affect the printing time of the same specimen at all.

7.5.4.3 Weight

Material	Layer Height (mm)	Raster orientation (°)	Ave. Weight (g)	Average (g)
BQ PLA	0.1	45/-45	11.09	11.61
		0/90	12.13	
	0.2	45/-45	11.44	12.03
		0/90	12.61	
	0.3	45/-45	10.81	10.95
		0/90	11.09	

Table 18: Measured weights of PLA tensile samples

Material	Layer Height (mm)	Raster orientation (°)	Ave. Weight (g)	Average (g)
PP CFPLA	0.1	45/-45	11.39	11.60
		0/90	11.80	
	0.2	45/-45	11.74	11.96
		0/90	12.17	
	0.3	45/-45	11.38	11.06
		0/90	10.74	

Table 19: Measured weights of CF PLA tensile specimens

Table 18 and Table 19 above depict the average weight of each sample set for both PLA and CFPLA specimens. It is observed that for both materials, samples printed

with 0.2mm layer height are the heaviest and samples printed with 0.3mm layer height are the lightest. In addition, for all layer heights, samples printed with linear orientations are heavier when compare to the samples printed with diagonal orientation. It is assumed that as samples were printed linearly, the roads extruded in building the raster to fill the tensile specimen dimension is more packed, thus less gap between each roads, than the one which are printed with diagonal raster.

Figure 33 and Figure 34 below depict the normalized values of tensile strength by weight and printing time against layer heights for each materials. For PLA, normalizing strength by weight shows a slight decrease at 0.2mm layer height but the value is just by 0.3 MPA/g. As for CFPLA, all layer height show values in the range of 1.9 MPA/g.

It is no surprise that the graphs show a linear increase when normalizing tensile strength by printing time as it takes longer to print parts at lower layer height,

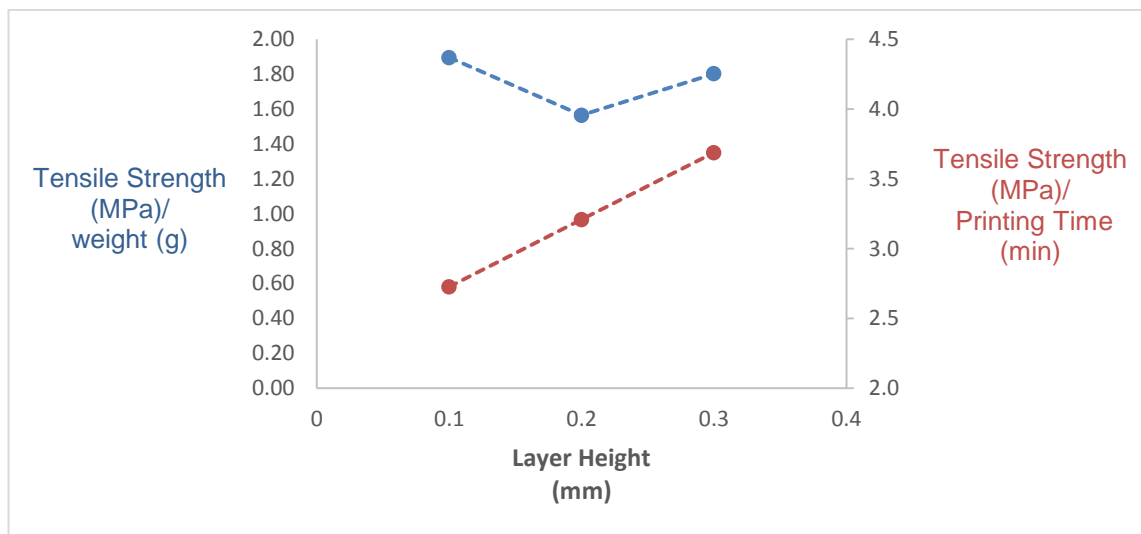

Figure 33: Performance of PLA tensile specimens against weight and printing time

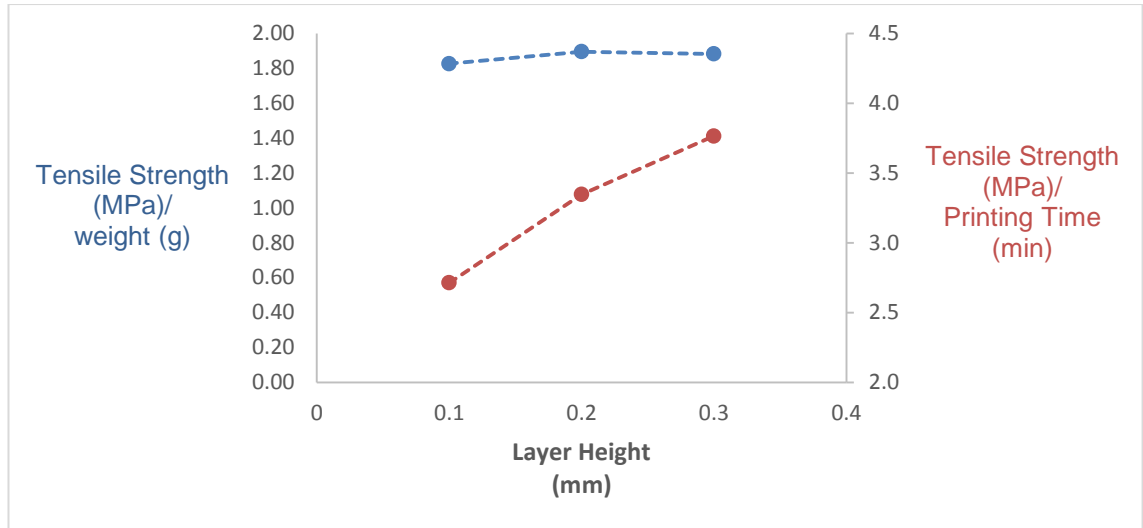

Figure 34: Performance of CF PLA tensile specimens against weight and printing time

7.5.4.4 Materials Comparison

Mat.	Density ρ (g/cm ³)	Tensile Strength σ_t (MPa)	Tensile Modulus E (GPa)	Specific Tensile Strength σ_{St}	Specific Tensile Modulus E_s	Approx. Price (£/100g)	$\sigma_{St}/\text{£}$	$E_s/\text{£}$
PLA	1.24	41.72	2.85	34	2	1.6	21.03	1.44
CFPLA	1.30	53.29	5.52	41	4	8.2	5.00	0.52
CFABS	1.08	26.27	3.70	24	3	6.1	3.99	0.56

Table 20: Comparison of material performance

As specific strength and specific modulus is simply strength-to-weight and modulus-to-weight ratio, it becomes an extremely important factor in material selection for an application that require parts build with enough strength and stiffness at relatively low cost.

Table 20 displays the densities and tensile properties (excluding tensile strain) of the three materials for parts printed at 0.2mm layer height with diagonal raster orientation where their specific tensile properties are then calculated. Furthermore, the approximate price per 100g unit was also shown and the cost per unit of tensile strength was calculated. The specific properties of the materials were calculated using equations (2) and (3):

$$\sigma_{St} = \frac{\sigma_t}{\rho} \quad (2)$$

$$E_s = \frac{E}{\rho} \quad (3)$$

As can be seen, CFPLA has the highest specific tensile strength and specific tensile modulus between the polymers compared. This means that CFPLA has the best strength and modulus at a relatively low weight. Therefore, CFPLA would be the best material for a part that requires a high stiffness. Although CFPLA shows a great stiffness to weight ratio, it has the lowest specific modulus to cost ratio which means that CFPLA offer the highest stiffness but at a higher price. CFABS has the lowest specific tensile strength while PLA has the lowest specific tensile modulus. Although PLA has a lower specific tensile strength than CFPLA and the least specific tensile modulus than the other two materials, it has a relatively high cost per unit specific properties. Comparing PLA and CFABS, PLA is more suitable for part which requires a higher strength while CFABS is more suitable for part which requires a higher stiffness.

7.6 Conclusions

The mechanical properties of PLA and CFPLA components were characterized through standard tensile tests to determine tensile strength and elastic modulus. Based on the analysis, both materials bulk filaments experienced an increase of stiffness after extrusion. The effect can be seen significantly for CFPLA which the modulus of its extruded part is approximately double its filament's modulus. Meanwhile, for PLA, the increase in modulus of printed parts is in the range of 20-30% from the bulk filament's modulus.

In terms of raster orientation, the linearly printed samples had higher tensile strength and modulus making it stronger than the diagonally printed samples. Indeed, some samples showed in contrary to the others which can be seen for 0.2 and 0.3mm layer height CFPLA specimens, but with a small difference. The tensile strength of diagonally printed CFPLA samples of 0.2mm layer height is 53.29 MPa, 4.14% higher than the linearly printed samples of the same layer height. Moreover, tensile the tensile strength of diagonally printed samples with 0.3mm layer height of the same material is 48.81 MPa, 2.8% higher than the linearly printed samples. In comparison to the other samples, the linearly printed samples exhibit tensile strength with more than 10% higher in difference to the diagonally printed samples. The effect of raster orientation brings no complication on the tensile modulus as all the

samples printed with a linear pattern exhibit higher tensile modulus to the diagonal printed samples.

In terms of layer height, no final conclusion could be made as both materials shows a contradiction in results. They showed that maximum strength is achieved at 0.1mm layer height for PLA and 0.2mm layer height for CFPLA, while the minimum strength for PLA is at 0.2mm layer height and 0.1mm layer height for CFPLA. However, both materials show similar results in tensile modulus which can be achieved with 0.1mm layer height.

In conclusion, a complex phenomenon can be seen in FDM built parts. Even though various factors are known to play an effect on the mechanical properties and performance, it is difficult to assign exact reasons on their interactions and relation to one another. However, some of the possible parameters have been outlined and it can be said that reduction in distortion is necessary requirement to obtain an optimal mechanical properties and performance.

7.7 Future Work

Building parameters in FDM process includes build orientation, raster angle, contour width, number of contour and layer height had been proven to play a fundamental role in improving mechanical properties of FDM printed parts. However, with basic user friendly slicing software such as Cura, FDM users might encounter with uncontrollable parameters during printing process such as raster to raster gap (RRG) or raster to contour gap which indirectly occur when changing the default building parameters. These gaps had also been proven to affect the mechanical properties of a part. Ahn et al. [9] revealed that negative value of RRG increased the ultimate strength of a 0/90° art when compared to RRG of 0mm. Therefore, future work may include applying these two established methods to modify the build parameters for improvement in mechanical properties:

- Insight revision method
- Visual feedback method

These methods focuses on examining low magnified test specimens and rendering the build tool-path on removal of air gaps between raster to raster and raster to contour, thus reducing void formation and distortion, which appeared to bring a

positive impact on inter laminar bonding of FDM parts, hence improving mechanical properties and performance.

8. Microscopy

8.1 Objectives

Since the first steps of the project, the importance of analysing some micro scale aspects of the printed samples came to the attention of the group. As the project was focusing on structural integrity of parts, the group members expected the knowledge of some of these aspects to clarify questions about structurally weak spots. Also, this would probably help optimize printing parameters in order to enhance quality of the prints in terms of possible gaps and surface quality. Some of the main aspects to be analysed were: fracture patterns; printing parameters reliability and repeatability; carbon fibre presence and arrangement in reinforced filaments and printed parts; filaments solidity. These are addressed separately in the following paragraphs.

8.1.1 Analyse Fracture Patterns

As tensile tests were carried out with dozens of specimens printed with several different materials and printing configurations, looking at the fracture patterns could help understand if there were any specific spots or layers which played important roles in determining the amount of strength each specimen would be able to take and therefore how to heighten this value.

8.1.2 Confirm Reliability of Printing Parameters

Before printing repeatability and other aspects of the printing process being considered, it was essential to check if the set parameters were actually being printed in the samples. For example, there was the need to control if the fully infilled printed specimens were in fact 100% solid or if there was any kind of gaps or bubbles in between the layers.

8.1.3 Control Printing Repeatability

Although running tests in order to decide on the best parameters to print functional parts, this information would be useless if the printer's capability of reproducing the same prints every time was not something to rely on. That is the main reason why

analysing sets of samples and checking how similar they were and if there was any specific parameter that could vary from one print to another was a key point.

8.1.4 Research Carbon Fibre Reinforcement

While choosing the materials to work with, carbon fibre reinforced filaments came to the group's attention as they were expected to offer higher values of maximum bearable strength. However, none of the suppliers provided information about how the carbon fibre was inserted in the filament and if it was in powder or in some set conformation. Therefore, it was important to check if the fibres were visible and how they would be arranged inside both the filament and the printed parts.

8.1.5 Check Solidity of Filaments

The group wanted to investigate the conditions of the acquired filaments. The analysis should look for any inconsistencies, bubbles or impurities that could be inside them in order to investigate if and how these could affect prints and if something could be done to avoid such effects.

8.2 Execution

In order to address all of our objectives, apparatus to be used to analyse the filaments and samples should be chosen. By the time the analysis started, two choices from the available options at the University were considered and during the procedure a third one came up as well. All three are listed and described in more detail in this section.

8.2.1 Equipment Options

The first option considered by the group was the electron microscope at the Advanced Materials Research Laboratory under the responsibility of Gerry Johnston. The analysis started by looking at the fractures to understand if there was any pattern between them. However, the first images from the electron microscope were not very elucidating. Therefore, the focus was changed from analysing fractures to observing the other aspects listed in section 8.1. To do so, the best choice was using an optical microscope, with the assistance of the metallographer James Kelly. Using this microscope it was possible to obtain multiple relevant images. Later on, more consistent images were taken using an electron microscope and a USB optical microscope was used as well. The images are presented in the following sections.

8.2.2 Scanning Electron Microscope

The scanning electron microscope (SEM) works by shooting a beam of electrons into a specimen in a vacuum chamber. The electrons reflected by the specimen travel through electromagnets to later form the image of the specimen. Therefore, it is possible to look at basically any sort of object shapes and that is why using this kind of microscope to look at the fractures was considered. Optical microscopes are more accurate working with flat surfaces, thus not being a good choice to look at fractures. Unfortunately, the images from the first electron microscopy were not very elucidative but they are presented for any needed reference in Figure 35 and Figure 36.

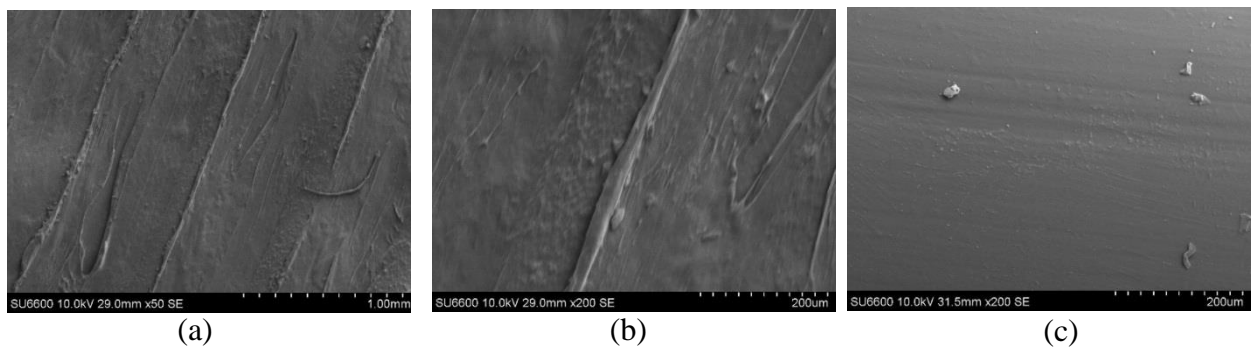

Figure 35: PLA test specimens – (a) x50 (b) x200 (c) x200

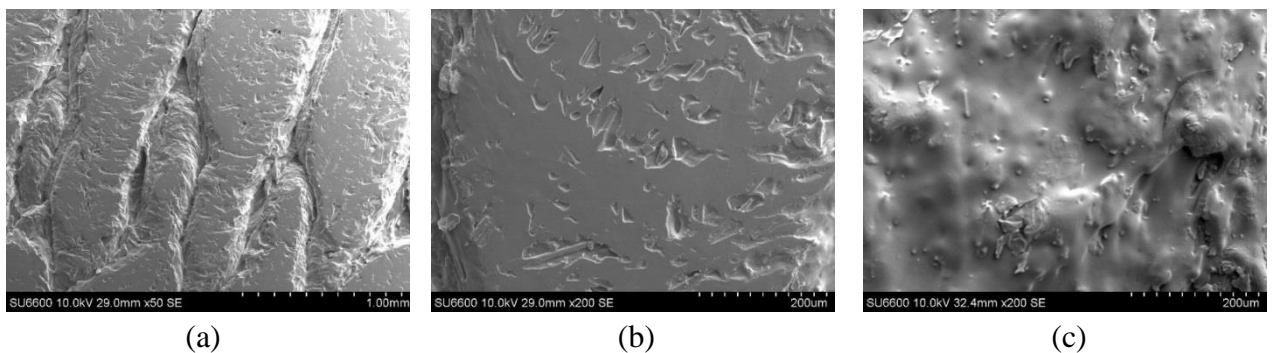

Figure 36: Carbon Fibre PLA test specimens - (a) x50 (b) x200 (c) x200

The second run of analysis using the electron microscope, however, revealed some interesting images on fractures of the four test specimens analysed. The images are presented for reference in Figure 37 to Figure 40.

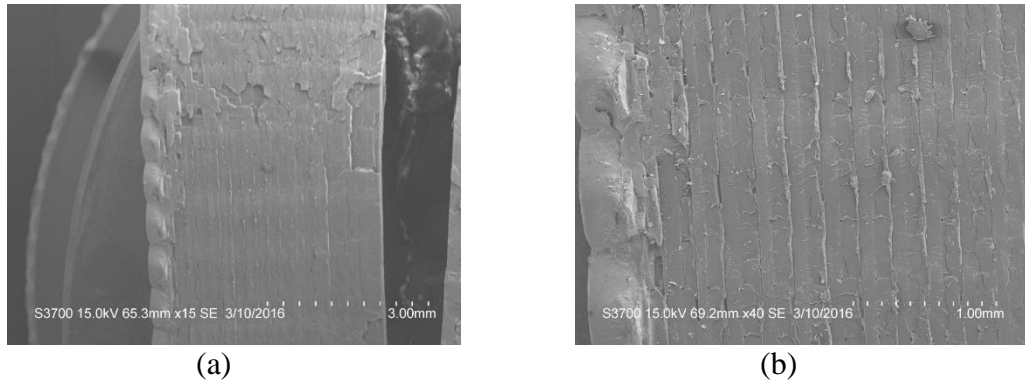

Figure 37: Linear PLA fracture surface (a) x15 (b) x40

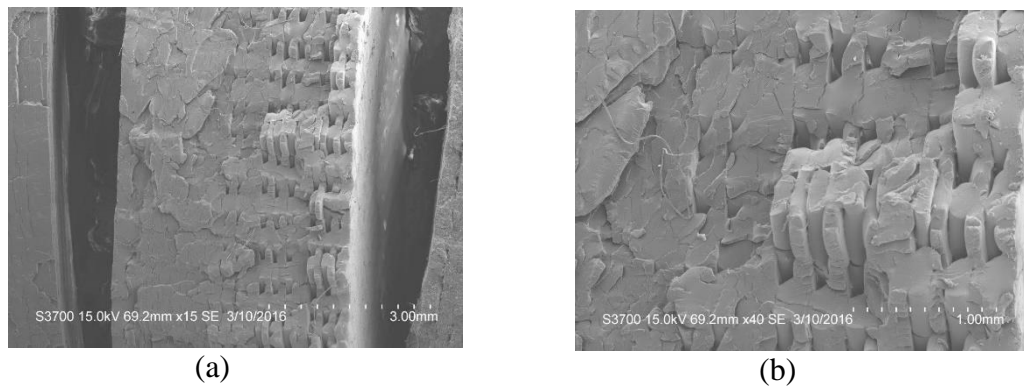

Figure 38: Diagonal PLA fracture surface (a) x15 (b) x40

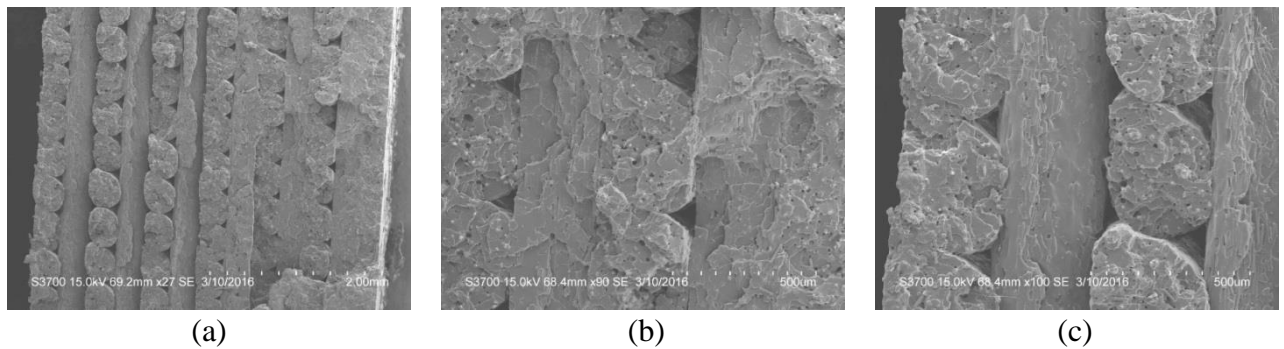

Figure 39: Linear CF PLA Fracture Surface (a) x27 (b) x90 (c) x100

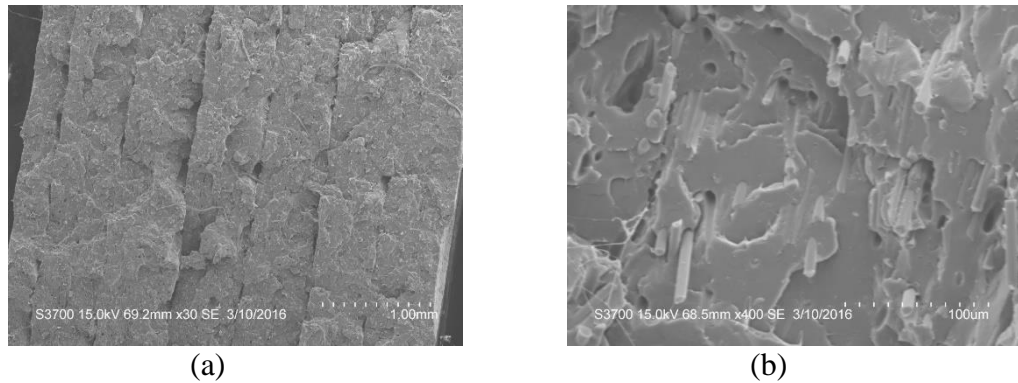

Figure 40: Diagonal CF PLA Fracture Surface (a) x30 (b) x400

8.2.3 Optical Microscope

Optical microscopes work in a much simpler way when compared to electron microscopes. These use only visible light and magnifying lenses to generate the final images. However, they usually provide satisfactory images only when looking at flat surfaces, so the focus was now on the other objectives such as checking the solidity of filaments and printing quality and repeatability. The images obtained are presented in Figure 41 to Figure 51.

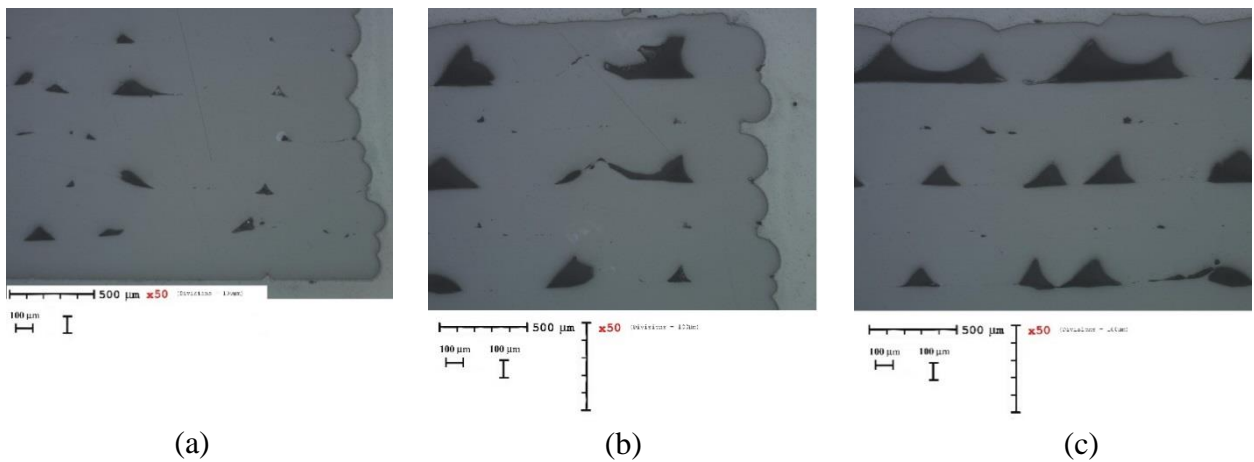

Figure 41: Diagonal PLA - (a) bottom corner (b) top corner (c) middle of top surface

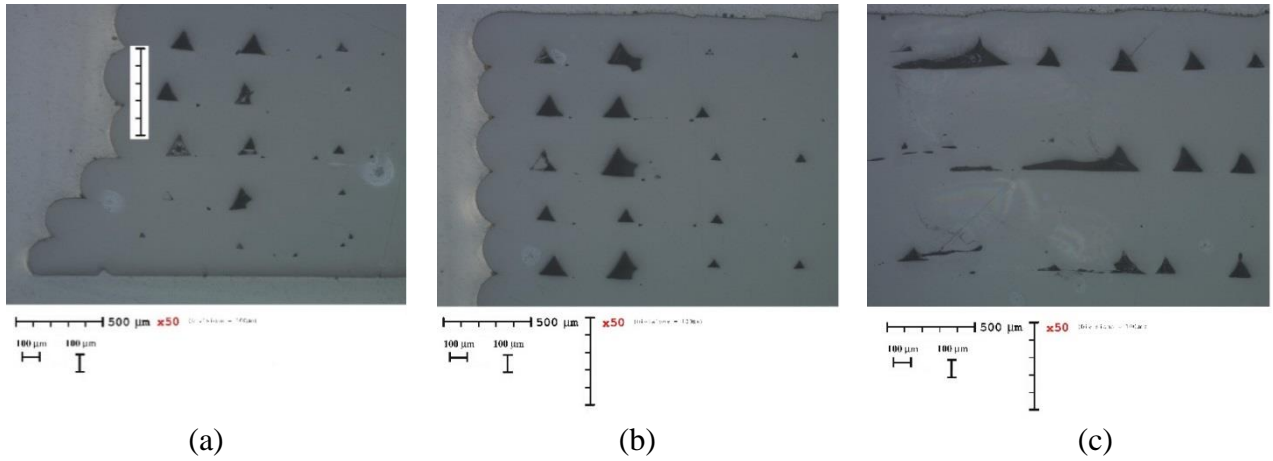

Figure 42: Linear PLA (a) bottom corner (b) top corner (c) middle of top surface

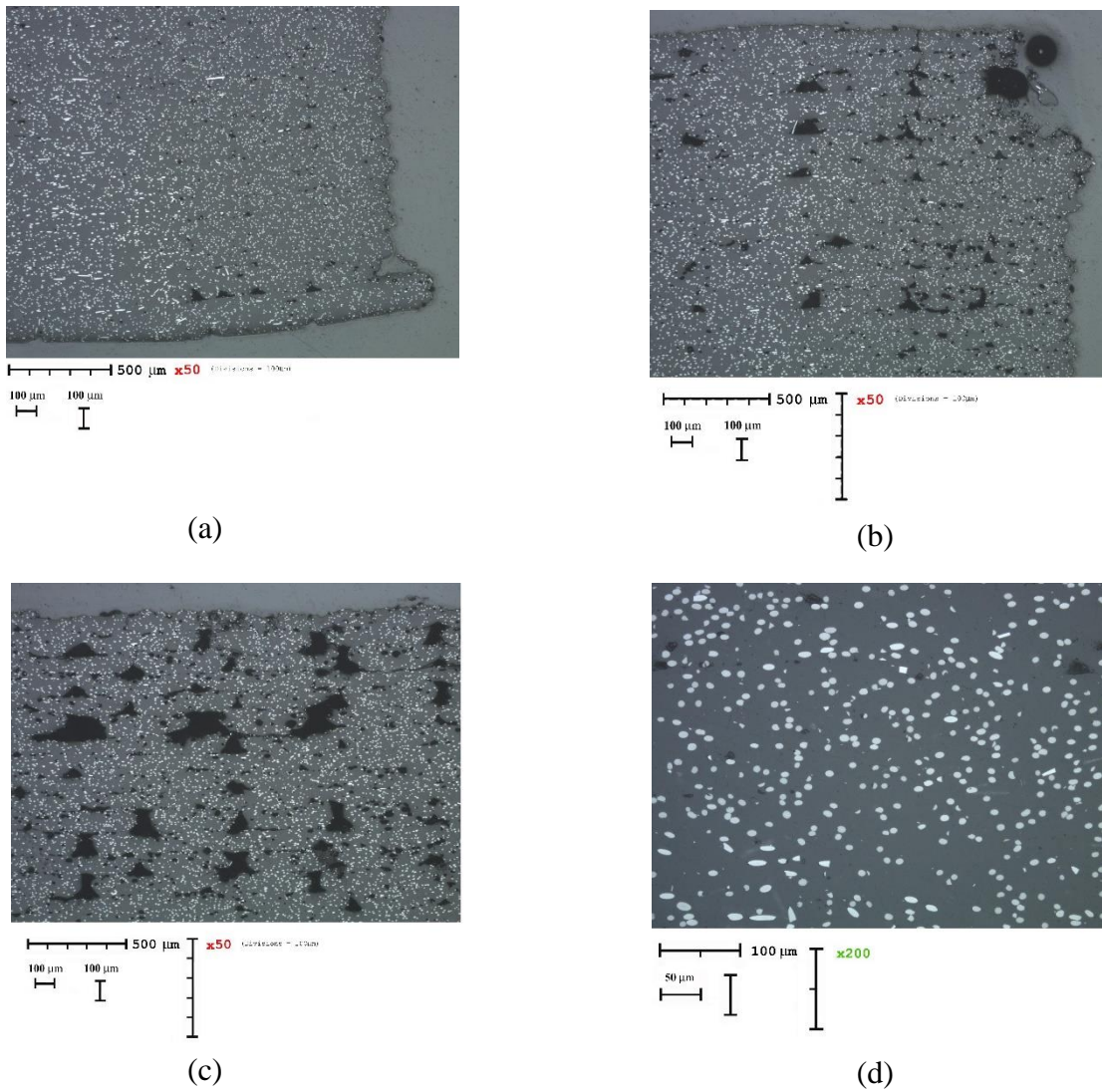
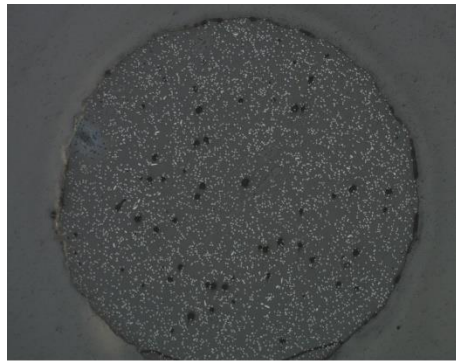
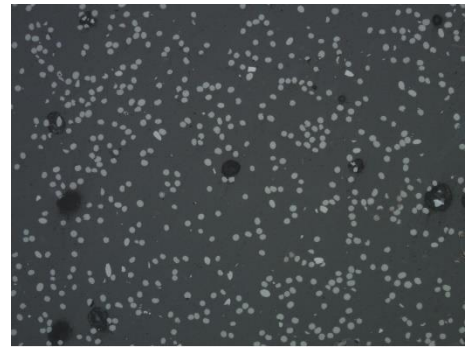

Figure 43: Diagonal CF PLA (a) bottom corner (b) top corner (c) middle of top surface (d) middle near base



(a)



(b)

Figure 44: CF PLA filament perpendicular cross-section (a) x50 (b) x200

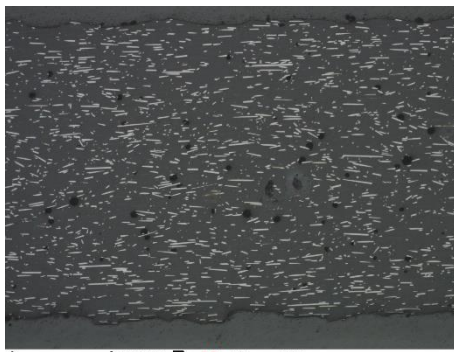

(a)

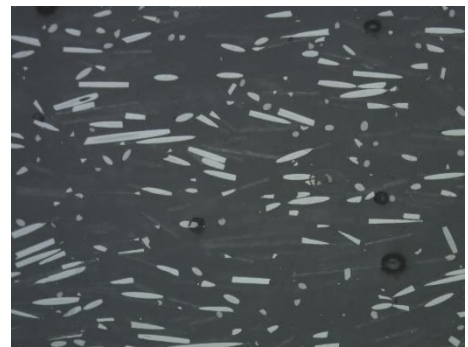

(b)

Figure 45: CF PLA filament longitudinal cross-section (a) x50 (b) x200

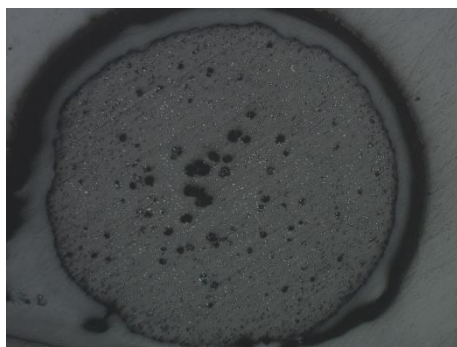

(a)

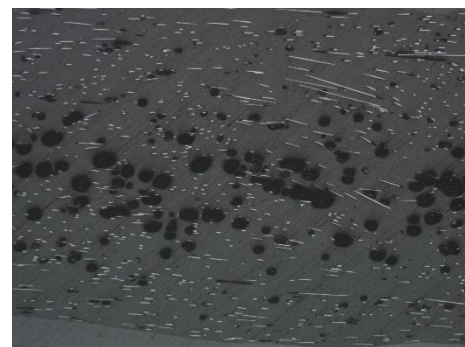

(b)

Figure 46: CF ABS filament cross-sections (a) perpendicular x50 (b) longitudinal x50

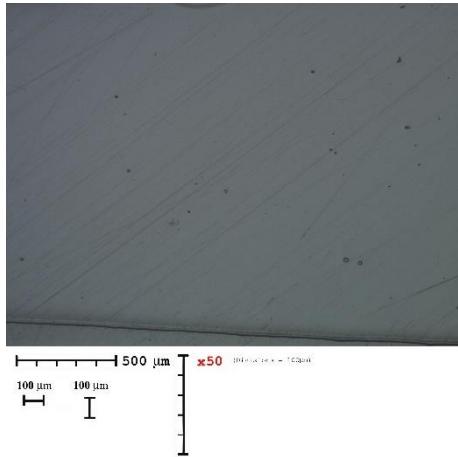

Figure 47: ColorFabb XT-CF20 Filament, longitudinal section x50

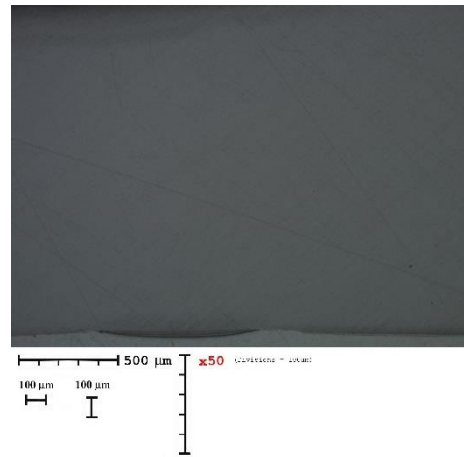
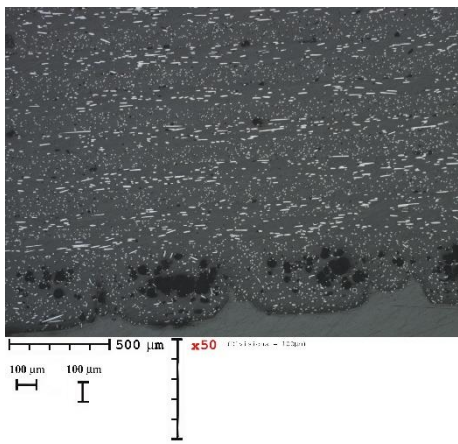
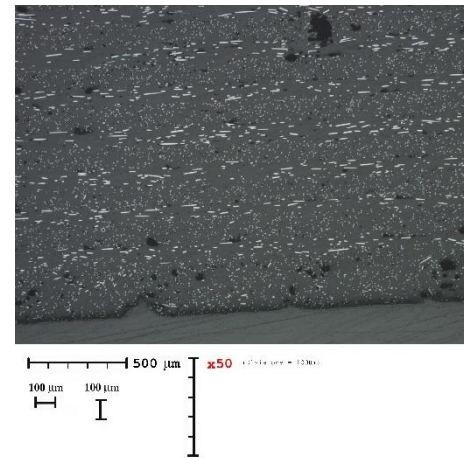

Figure 48: BQ PLA filament, longitudinal section x50



(a)



(b)

Figure 49: CF PLA linear infill specimen middle of base x50. (a) and (b) are different specimens

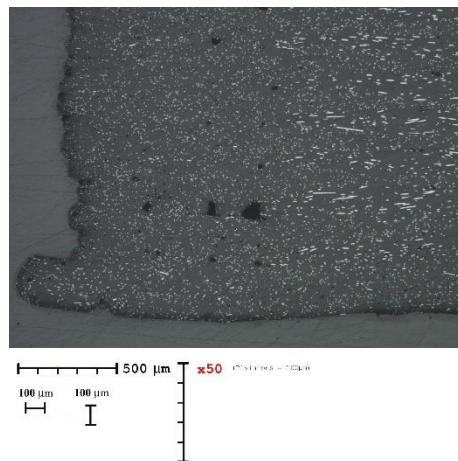

(a)

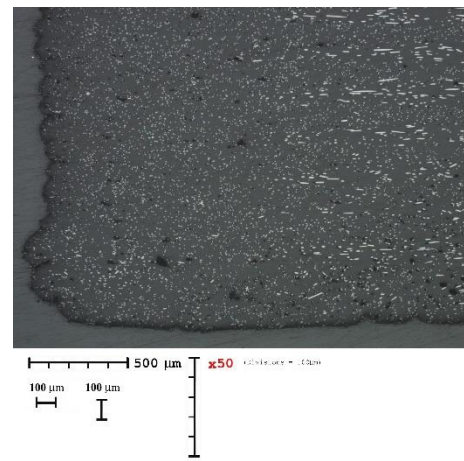

(b)

Figure 50: CF PLA linear infill specimen bottom corner x50. (a) and (b) are different specimens

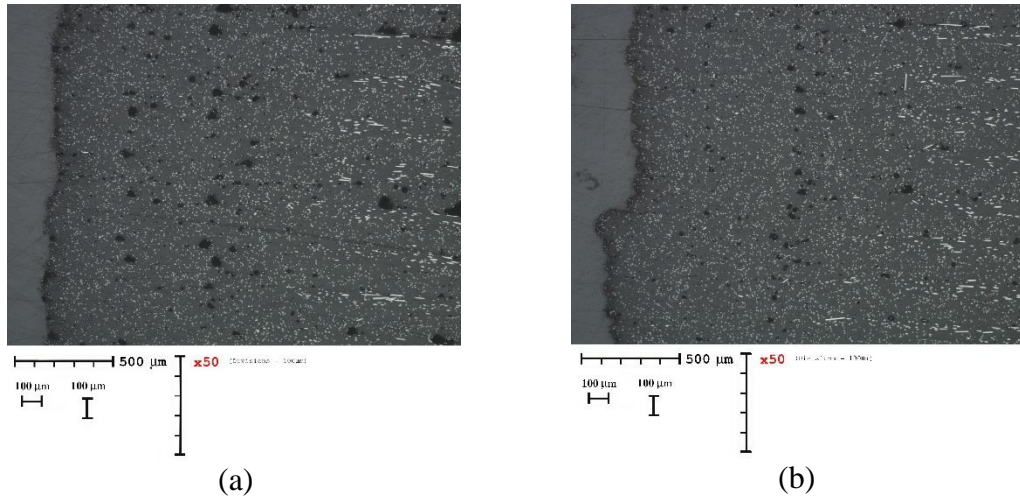

Figure 51: CF PLA linear infill specimen mid height side wall x50. (a) and (b) are different specimens

8.2.4 USB Microscope

While running analysis using the optical microscope, Dr. Comlekci raised attention to the possibility of using a USB optical microscope to allow quick analysis of samples. With this, additional observations were made, particularly with regard to the carbon fibre specimens. As expected, the results were not as clear as with the main optical microscope but it did provide a means of quick analysis without the need for sample preparation.

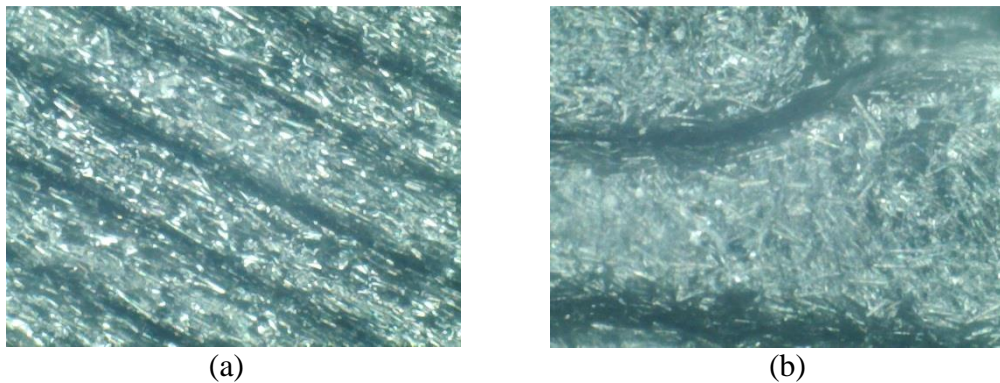

Figure 52: CF PLA linear infill specimen x200 (a) top surface (b) bottom surface

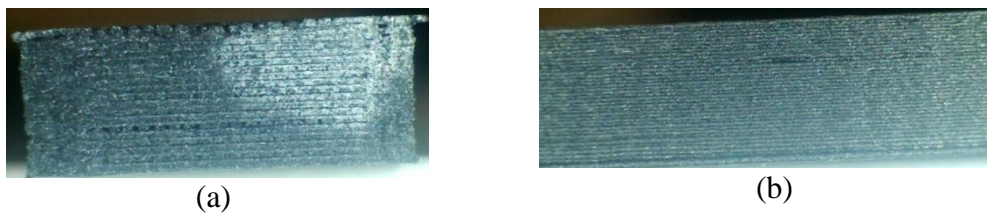

Figure 53: CF PLA linear infill specimen (a) fracture surface (b) side wall

8.3 Observations

The numerous images obtained from the microscope analysis made possible to observe several aspects of the specimens and filaments. Some of which were already expected to be the way they were and some that were not predicted but could help understand better the issues related to printing and maybe improve the final results of prints. In this section, each one of the objectives presented in section 8.1 will be addressed, describing the findings regarding each topic, and presenting conclusions based on the observation of the images presented in previous sections.

8.3.1 Fracture Patterns

To observe the fractures and identify patterns, the best available option was an electron microscope. Images of four different test specimens were taken. One of the main aspects to be analysed was the differences to be found between fractures of specimens with linear and diagonal filling. This takes into consideration whether the specimen was printed with each layer being laid aligned with the longitudinal axis of the specimen or with layers at 45 degrees from such reference. The specimens observed were:

- Linear filling, PLA, 0.1mm layer height (Figure 37)
- Diagonal filling, PLA, 0.1mm layer height (Figure 38)
- Linear filling, carbon fibre reinforced PLA, 0.3mm layer height (Figure 39)
- Diagonal filling, carbon fibre reinforced PLA, 0.3mm layer height (Figure 40)

It is possible to see that fractures are not completely uniform in any of the specimens with carbon fibre reinforcement, as per Figure 38(a) and Figure 39(a). This may be due to difference in terms of how well the filament is fused in each layer as the bottom layers appear to be more homogeneous. The critical fracture points appear to be as expected for the linear filling specimens, with fracture occurring between the layers at 0 degrees as in Figure 39.

8.3.2 Reliability of Printing Parameters

In this section, the most relevant aspects observed regarded layer height and presence of voids, especially as these were supposedly 100% infill specimens with uniform layer height. The optical microscope analysis was deemed most suitable for

this purpose, to observe the cross sections of the printed specimens in different configurations. The specimens observed were:

- Diagonal filling – PLA – 0.2 layer height (Figure 41)
- Linear filling – PLA – 0.2 layer height (Figure 42)
- Diagonal filling – carbon fibre reinforced PLA – 0.1 layer height (Figure 43)

There is little variation in layer height shown in the images taken. With regard to solidity of the specimens, there were some considerable differences to observe. All analysed specimens were printed with 100% infill set, and thus should be completely solid but it was found that this is not the case.

In the PLA specimens, it is possible to see signs of incomplete fusion in some parts of both of the PLA specimens. The quantity of voids and size vary when comparing different filling patterns, being more numerous and regular in the linearly filled specimen, but in some cases larger in the diagonally filled one (Figure 41 and Figure 42). Regarding linear filling, the largest voids are about 150 microns wide, with area of approximately 11,250 microns squared, while the diagonal filling presents voids up to 33000 microns squared (disregarding top layers). On the top layers there are signs of incomplete fusion with much larger voids, especially in the diagonally filled specimen as Figure 41(c).

It was possible to observe that the carbon fibre reinforced PLA specimen contains much smaller voids when compared to the PLA ones, especially on the bottom layers, where there are no considerable voids in said specimen. This may be due to the use of a heated bed for printing with carbon fibre reinforced filament.

8.3.3 Printing Repeatability

The printer used in this project is a fairly simple and low-cost device, and was built by the group members themselves following the instructions provided with the self-build kit. For testing, it was important to ensure that the prints were regular enough to rely on it to print structural parts and test specimens without problems occurring due to printing inconsistencies. To check the repeatability of the printer, five specimens that were printed under the exact same configurations were chosen and analysed in an optical microscope. Only the most relevant images are presented in

this report. The specimens observed were those of the carbon fibre PLA filament, with 0.1mm layer height and linear infill pattern, as in Figure 49 to Figure 51.

Strategic areas of the cross section view of each specimen were observed, such as corners and top and bottom layers. In general, there are not many considerable differences between the characteristics of the specimens.

Two of the relevant differences found were in the bottom layer of the specimens. The first one is that while three of them showed signs of incomplete fusion in the first layer, as in Figure 49(a), two specimens seemed to have a better start in their prints, as Figure 49(b). Also, in the bottom corner, on four occasions, it is possible to observe that the first layer is a bit wider than the top ones, seeming to have spread more than it should (Figure 50(a)). This is not visible in only one of the analysed specimens (Figure 50(b)), which is one of the specimens that showed best fusion in the previously discussed topic. This may be caused by small differences in the temperature of the heated bed during the print job.

The third significant difference was in one of the side walls of one specimen. There is a small step because the bottom layers in this case are wider than the top ones Figure 51(b). This is seen as an imperfection on the surface of the specimen and could affect the performance of a functional part in terms of acting as a stress concentrator, for example. Probable causes for this issue can be any subtle movement of the table where the printer is based or small jumps of the extruder itself due to instability, and it is hard to guard against these occurrences in simple printers such as this.

8.3.4 Carbon Fibre Reinforcement

In this section, the key aspects to be analysed were whether the fibres are visible in the filaments and specimens; the alignment of fibres if they are present, and also how significant the amount of fibre is compared to the full volume of each filament. The filaments and specimens observed were:

- Carbon fibre reinforced PLA filament (Figure 44 and Figure 45)
- Carbon fibre reinforced ABS filament (Figure 46)
- ColorFabb carbon fibre filament (Figure 47)
- Linear filling, carbon fibre reinforced PLA with 0.1mm layer height (Figure 52)

The supplier of the ColorFabb filament does not provide any specific information about the actual composition of it, but the company states that it is a polymer called Amphora3D, designed for 3D printing, and that it is reinforced with carbon fibres at 20% weight. However, it is not possible to see any traces of fibres in this filament as can be seen in Figure 47. Thus, either there is no reinforcement in this filament or it is made with a powdered carbon and therefore it is not possible to see it in a microscope and draw any conclusion. This was a surprising result, as the specification of the product clearly states it has embedded chopped fibres.

Concerning the filaments in which it is possible to see carbon fibres, the PLA and ABS varieties show some similarities. In both filaments some longitudinal alignment of the carbon fibres is visible as per Figure 45 and Figure 46(b); however it seems to be more noticeable in the PLA. This may be explained if the fibres reinforcing the ABS filament are longer than the ones in the PLA and so are more likely to sit off-axis. The longest fibres that are aligned and seem to be fully visible in the PLA filament are approximately 100 micrometres, while in the ABS filament it is possible to see fibres about 4 times longer. Therefore, the comments above regarding the orientation of the fibres being an effect of length may be valid.

Regarding the ratio of fibre quantity to the total volume of material, the PLA filament presents a much higher value in comparison with the ABS. Most fibres of both filaments are very close to a diameter of 8.5 microns, but the number fibres in the PLA one is clearly higher. It is estimated that 15% of the total volume of the reinforced PLA filament consists of carbon fibre, while this approximated percentage falls to 8% in the ABS filament.

8.3.5 Solidity of Filaments

To investigate the solidity of the filaments, the best option found by the group was to look at them in both cross section and longitudinal section using an optical microscope. However, only the most relevant images are presented in this report. The filaments observed were:

- Carbon fibre reinforced PLA filament (Figure 44 and Figure 45)
- Carbon fibre reinforced ABS filament (Figure 46)
- ColorFabb filament (Figure 47)
- PLA filament (Figure 48)

The PLA filament does not present any kind of impurities or voids, likely indicating a high quality production process. In terms of solidity, the filament that is closest the characteristic of PLA was the ColorFabb filament, which also does not present a considerable amount of voids. Carbon fibre reinforced PLA shows that some voids are present that are likely to be air bubbles, shown by the dark regions in Figure 44 and Figure 45. However, in the carbon fibre reinforced ABS filament there are more numerous and bigger voids, some with diameter close to 100 microns shown by the larger dark regions in Figure 46. The voids are mainly located in the central core of the filament, whereas the outer regions show fewer discontinuities.

8.4 Conclusions

The observation of all images acquired with the microscopes helped understand better the most relevant issues surrounding the printing process and, above all, confirm assumptions made during the project due to related research of previous works. However, there are also findings to collect from such observation. Most relevant are related to the filaments themselves, especially those with carbon fibre reinforcement. The carbon fibre filaments are less well documented, and so the findings regarding their composition are valuable to future work. What was also noted, and is interesting, is that the ColorFabb filament does not appear to provide any internal fibres – a fact contrary to their marketing materials – and so it would not be recommended to be considered for use as a reinforced filament.

8.5 Future Work

The analysis undertaken in this project looked at basic printed structures, those of the tensile test specimen, since they were being produced by the group for other purposes. Therefore the knowledge gained in respect to how well or consistently they were printed is of great interest. However, no microscopy was carried out on more complex components, where the geometry is more complex. Since it is envisaged that 3D printed parts will be suitable for structural applications, gaining an understanding of how well these more complex shapes are manufactured would be vital. Comparison of the specimens printed with this low-end printer should also be compared with specimens printed on high-end hardware should also be of interest, as obtaining a knowledge of whether high end machines bring about more reliable performance. It may be the case that there is no discernible difference, and so the use

of low-end hardware would be advocated, however at present there is no justification of this hypothesis.

9. Component Design and Printing

When setting out the scope and objectives of the project, the supervisor expressed his interest in the opportunities that 3D printing would present in the manufacture of functional components. It was hoped that the benefits of using composite printer filaments could be exploited to produce parts that exhibit good stiffness and strength characteristics, while being able to produce complex geometries relatively quickly and on low runs of production numbers. The particular application envisaged for this was within student projects, particularly those involving the design and manufacture of aeroplanes, such as the BMFA and AIAA flight competitions. However, it was hoped that the insight gained into the possibilities with aerofoil design would yield knowledge that is transferrable into other applications.

9.1 Challenges

It was decided that the area of application to be investigated during the course of the project was that of the aerofoil construction. The aerofoils used in the planes are mostly manufactured by a standardised process, whereby the wing is constructed from a number of components, each performing a different function. The standard process involves the wing shape being formed by a number of balsa wood ribs, which are spaced along reinforcing rods. The function of the ribs is to provide the shape of the aerofoil, while the rods provide the longitudinal stiffness. The rods are commonly made from a material such as carbon fibre composites that have the benefit of high stiffness at low weight.

The ribs are effective in forming the aerofoil shape along most of the section; however a different system must be utilised at the leading and trailing edges. This is necessitated by the need for the precise shaping at these edges, as well as the requirement for a continuous section down the length of the wing. In the current system, the ribs are shaped such that they can be supplemented at the front and back by balsa wood veneers which can be shaped to the required form manually by sanding. The whole structure is then wrapped in a film covering that provides the active lift surfaces.

The downside of this system is that the shaping components at the leading and trailing edges have no load bearing capacity, other than the relatively small lift force acting on the film surface. There is also the problem that the shape must be manually formed, which is ineffective in forming the exact shape required at these parts of the wing, where the shape can have significant effects on the performance of the wing. It was of interest to investigate the extent to which 3D printing techniques could be utilised to aid the manufacture of aerofoils in the context of model flight competitions. Additionally considered was whether 3D printing would facilitate more efficient component designs and whether using alternative aerofoil manufacturing techniques would provide a performance benefit.

It was also deemed important to discuss with the project groups working on aeroplane design to establish what they would find useful from an alternative design. In addition to the shaping problems encountered at the leading and trailing edges, the groups identified that it can be hard to maintain the aerofoil shape between the ribs. Between the ribs there can be sagging of the covering film, which arises from the fact that the ribs are relatively widely spaced, and the tensioned film is not held out by the ribs. They identified that the ability to increase the shaping ability of the ribs down the length of the aerofoil would be beneficial. However, to do this without having an adverse effect on the weight of the aerofoil is a challenge using the balsa wood rib construction method.

It was hoped that 3D printing could provide the manufacturing flexibility to allow alternative designs to be realised and ultimately provide improved aerofoil performance. Coupled with the introduction of composite filaments, it was hoped that functional structural components could be designed and printed, with greater flexibility over the overall design that is not possible using balsa wood. A number of avenues would be investigated, and potential issues or downfalls noted, as well as any obvious, unforeseen advantages.

9.2 Plotting Aerofoil Profiles

To plot the geometry of the aerofoil profile, the coordinates were obtained from the UIUC Airfoil Coordinates Database³. This database consists of coordinate data for a

³ http://m-selig.ae.illinois.edu/ads/coord_database.html

huge number of aerofoil profiles in the form of x-y coordinate values from an origin at the leading edge. The raw coordinate data can be processed and used to create a model of the aerofoil in a CAD environment such as PTC Creo. The process involved taking the coordinates in the form that they can be downloaded from the UIUC database, and composing them into a set of x, y, z coordinates that can be used to create splines in Creo. The data must be split into two halves: one for the top surface and one for the bottom surface, since the geometry will be created as two separate splines. Additionally, the coordinates provided in the database are only x- and y-coordinates and so z-coordinate values must be introduced for them to be suitable for use as spline points. Since the profile is 2-dimensional, the z-coordinate is always zero and so this is a simple task. The columns were required to be separated by a tab-stop and be given a header row (simply x, y and z) before being saved as a .pts file. This file-type is a format specifically for spline geometries in Creo. For this project, the data points were processed in both Microsoft Word and Microsoft Notepad. Word was used to add the third column, making use of the 'Find and Replace' function to replace carriage returns with tab characters. This was then copied to Notepad for saving as the .pts file.

Once the data points were in the correct format, a part file was created in Creo and a sketch created. In this sketch a new coordinate system was defined, which would be at the leading edge of the profile. A straight, horizontal line was then drawn from this origin with length 1 unit to act as the main chord of the aerofoil and adjust the length of the profile at a later stage. Two splines were then created, each with 4 points initially – one above the horizontal line and one below, with the start and finish points being the end points of the line. Once these were created they were selected individually and the definition changed to read the spline points from a file – that being the .pts files that were previously created. Once this was completed it was possible to alter the length of the line to reflect the chord length of the aerofoil. For this project, the length was limited by the size of the printer print bed, and so was set to a value below 200mm. Adjusting the length altered the splines proportionally so that the overall profile remained the same. At this stage the profile was fully defined as a sketch in the part file and could be used to create the geometry of aerofoil components, such as the ribs.

9.3 Design Concepts

The starting point for all designs was an FX 73-CL2-152 aerofoil, as this is the same as that being used by the AIAA flight competition group. By using this shape as a starting point, it was possible to make an almost direct comparison between the current wood design and any proposed printed design. Another reason for choosing this profile as a starting point is that the outside shape is relatively challenging for 3D printing, since the tail end is very fine, and has a sharp pointed profile. The profile was created as a sketch in Creo by the method described in the previous section and used as a guide for the creation of constituent components.

A number of different designs were derived, and each was investigated for its ease of printing and manufacture. These are explained in the sections below, and conclusions drawn from the experience and knowledge gained throughout the process.

9.3.1 Printed Ribs

The ribs were based on the standard version used by the AIAA flight group, then scaled down from approximately 30cm chord length, to 18cm. This was required due to the limited space available on the print bed. Consideration was then made to removing material to reduce the weight of the ribs. The overall goal here was to produce ribs that were of similar or less weight than the balsa wood ribs, and so the amount of material to be removed was significant.

A number of versions were proposed, but common to all of them were two features: cut outs at the leading and trailing edges for a veneer to be fitted in the same way as the currently used method with balsa wood; and two holes to be used to fit the rods that run down the length of the aerofoil to provide the overall stiffness along its length. An example of this can be seen in Figure 54. From there, as much material was removed as possible. The process was iterative, and somewhat trial and error, as prints were produced for each iteration before modifications were made to achieve better performance.

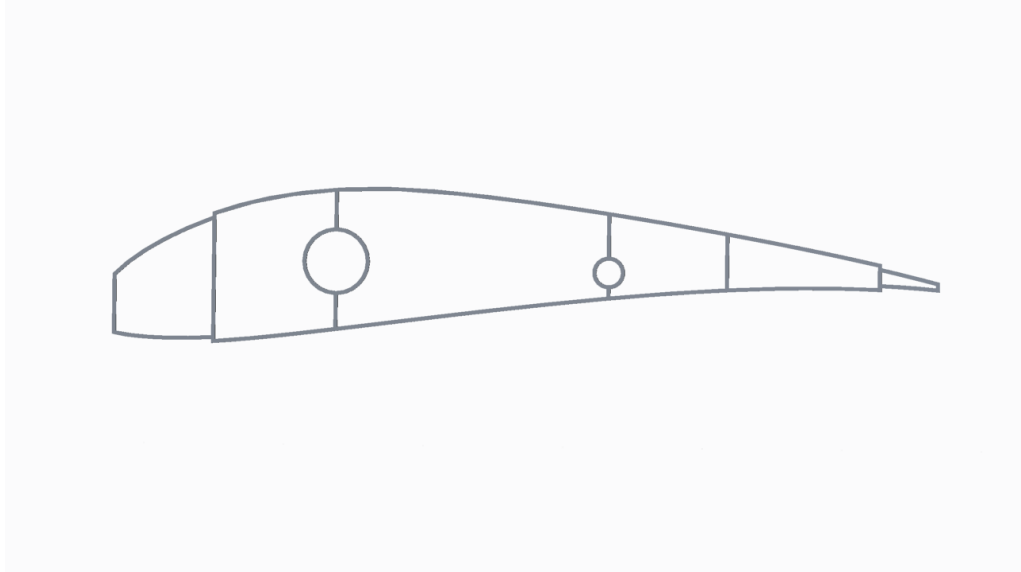

Figure 54: Printed Rib Creo Model

9.3.2 Printed Leading Edge and Trailing Edge

The third variation considered was that where the leading and trailing edges were printed, and the ribs designed to connect to these parts by a mechanical connection, similar to a snap-fit configuration. The idea behind this idea was that by printing the leading and trailing edges, not only would the shape be exactly as required, but also these could be used as load-carrying structural elements and so could reduce, or potentially negate, the need for additional stiffening rods within the wing. If possible, this could represent an opportunity to reduce the complexity of the manufacturing process and a subsequent weight reduction while maintaining performance. An example of a design utilising this concept is as shown in Figure 55 and Figure 56.

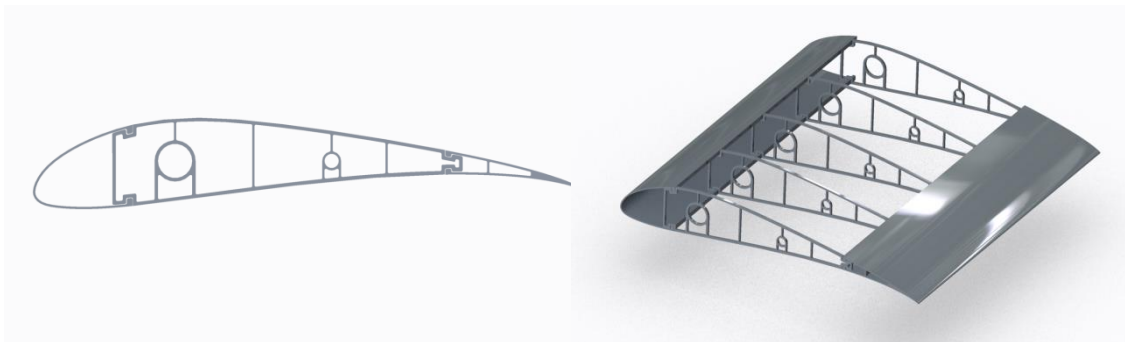

Figure 55: Profile of design concept utilising printed leading and trailing edges

Figure 56: Assembled section of aerofoil

9.3.3 All in One

The all in one model proposed as in Figure 57 and Figure 58 had the purpose of determining the feasibility of printing an entire wing as one piece. The form that this took was a solid outer perimeter with an internal cross-braced structure. This was a fairly complex process to model in Creo due to the lack of any straight lines on the structure, thus making it difficult to define the material to be removed to form the bracings within the section. This was eventually achieved satisfactorily by creating a number of sketches on different planes to remove the material in different directions, then finally creating the outer shell extrusion.

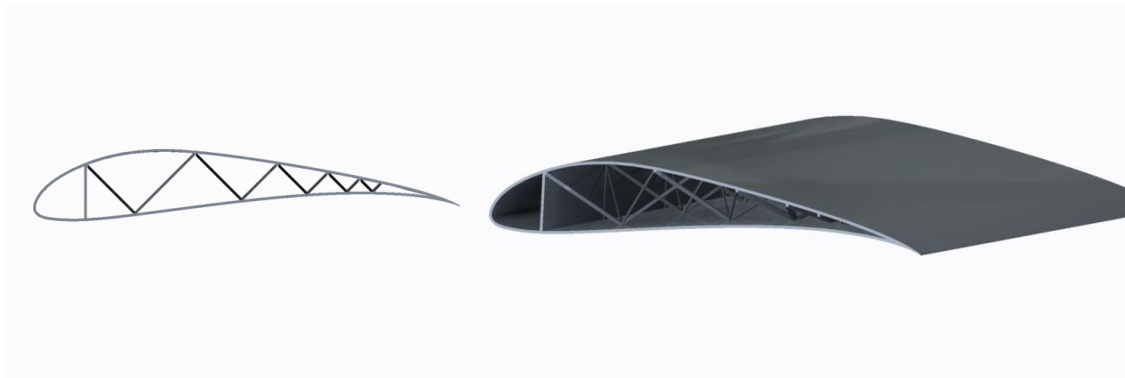

Figure 57: Profile of All in One Aerofoil Concept

Figure 58: Rendered view of section of All in One Aerofoil Concept

This process gave a satisfactory result, however it was a clunky process that was time intensive. It also had the downside of not being able to edit it easily, increasing the time aspect of creating a model in this way. The limitations of editing were attributed to the way in which Creo handles sketches, particularly those to be used for further processes such as extrusions. It lacks the ability to handle sketch components that are present for construction purposes, such as reference geometry and measurements, which must be removed for an extrusion to be possible. Therefore if the geometry is to be changed, it must be constructed from scratch. As a result of this, creating the different versions of this concept was a very slow process.

9.4 Printing

The designs that were proposed were printed using the Prusa i3 with the heated bed fitted and most of the designs were printed using both the plain PLA and carbon-fibre reinforced filaments. The plain filaments were used to confirm the calibration of the printer and to confirm that the GCode files were optimal. This saved the

carbon fibre filaments for the final prints only, which served to ration the more expensive filament for only the times where it was required. The other aspect of this was that the carbon fibre filament is more abrasive on the nozzle of the hot-end, and so reducing the amount of time it is used for will increase the life of the nozzle. Ensuring that the nozzle does not become too eroded is crucial to achieving reliable, accurate and high-quality prints. However, it was found that the two filaments did not print exactly the same as each other, thus it was necessary to use the carbon fibre filament from the start in order to properly investigate the printing performance.

It should also be noted that due to the limited size of the print bed, the size of the prints that could be achieved was limited. All printed components had to fit within the 200x200mm print area and so with respect to the AIAA flight group aerofoil, the scale of the printed components was slightly reduced by necessity.

For each design concept it was necessary to carry out a number of print attempts in order to obtain the best results. This involved varying the printing parameters to optimise the finished component. This process allowed a huge amount of knowledge to be gained about the limitations of the abilities of the printer, along with identifying the areas of good performance.

9.4.1 Printed Ribs

It was found that printing the ribs was fairly straightforward and that the geometry was well suited to being 3D printed. Since the components were quite thin, they could be printed in a short time making the process very efficient. Some issues were experienced with regards to creating reliable GCode files, which was attributed to the export of the .stl file from Creo. The GCode created was failing to match the geometry satisfactorily, in that it was failing to create curves and circular features without them becoming octagonal. By adjusting the resolution of the .stl export, this problem was eradicated.

It was found on the first attempts that the finished parts were significantly heavier than the balsa wood equivalent, however they were far superior in terms of stiffness. Thus more material could be removed to reduce both the weight and stiffness, since the loading on the ribs is relatively low, particularly the lateral bending load and so the stiffness requirement is less than the first iteration.

The material was removed by two methods: reducing the thickness of the perimeter and reducing the width of the part. Originally the ribs were printed at 3mm thick, as per the balsa wood ribs, however this was reduced to 1.5mm for the following iterations. This eventually gave a rib that was comparable in weight to the balsa wood ribs, however it was somewhat more flexible in some aspects. It had good rigidity around where the reinforcing spars would go, and as the other main load on each rib is the relatively small pressure load on the wrapped surfaces of the wing, it would likely be sufficient. The reduction in thickness did impact on the lateral bending stiffness, but when the nature of the loading on it as part of a fully constructed wing was taken into account, it is negligible in that direction.

The printing parameters such as the shell thickness and infill percentage were adjusted to suit the design. The ribs in this case were printed such that the shell thickness was set as the thickness of the perimeter, which prevented infill from being created and maintaining the filament alignment with the loading direction.

9.4.2 Printed Leading and Trailing Edge

Printing the leading and trailing edge components was somewhat problematic and required a lot of trial and error to achieve the desired results. The first orientation considered was when the profile is laid out on the print surface and built up in layers, gradually extending the length; the second was to orientate the fibres along the length and build the profile up in layers.

The first orientation printed was as Figure 59 and Figure 60 below. These printed without issue as the profile of each component was simple and could easily be built up layer by layer. There was no overhanging areas or particularly fine geometry, facilitating easy printing. The downside of this arrangement was that the joints between layers were along the length and so any bending load acted in the sense that would stress the interaction between layers.

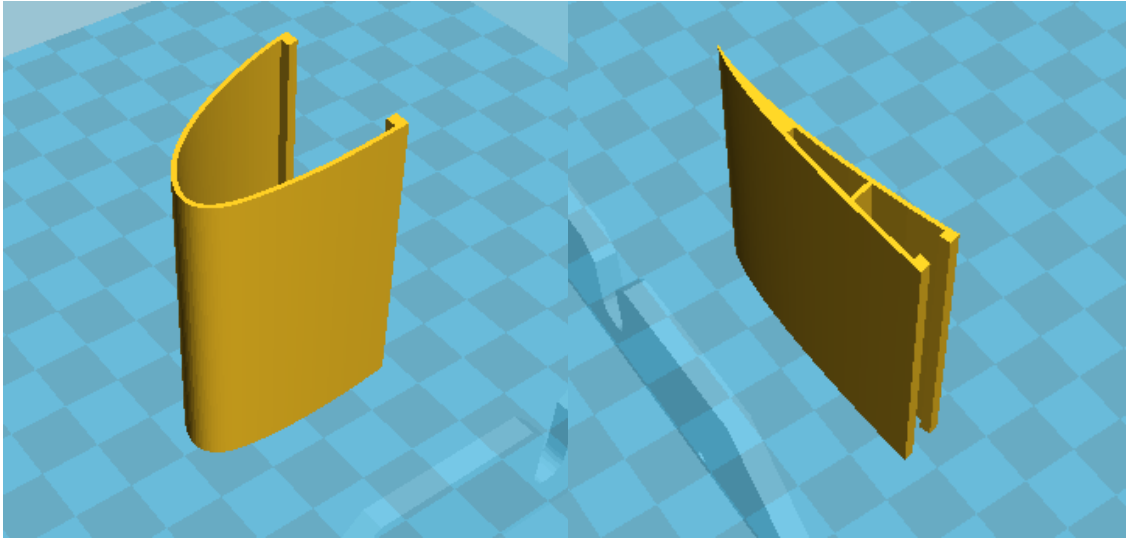

Figure 59: Leading Edge Orientation 1

Figure 60: Trailing Edge Orientation 1

The second arrangement was more desirable, but harder to achieve. It involved orientating the component such that the filament laid was orientated along the length of the aerofoil. This is beneficial as it ensures the strong direction is in line with the most likely loading direction – along its length – as well as because a long component could be printed by expanding the print bed in the x and y directions only, far easier to achieve than expanding in the z direction. However, a number of issues were encountered in achieving good results.

Firstly, it became clear that the orientation of the component on the print bed was important when preparing the GCode in the slicer software. This had a direct effect on the results as it could vary the angle of overhang that must be printed. Anything above 45° is challenging to print, since one layer is being laid where there is no material below it, and so support material had to be introduced when this was the case. Also, to aid the stability of the part while printing, a brim was added to the bottom layer. This also helped the component to stick to the print surface, as there was not always a lot of surface area to adhere to the base. The printing parameters were then tweaked to obtain optimal printed parts.

A number of orientations were tested for printing the leading edge as in Figure 61 to Figure 63 below. It was found that the most reliable orientation for printing the leading edge was as shown in Figure 64 below. This meant that as the shape was built up, the internal support structure supported the top layers as the overhang went

over 45° , and the top layers were neat. The printed leading edge using this configuration was as Figure 66.

Obtaining neat and accurate layers at the top was challenging, with an example of the poor finishing of the part shown in Figure 65. It was found that by increasing the shell thickness parameter the results were improved. This is because increasing the shell thickness has the effect of stopping the slicing software from creating infill. The part was designed to have a thickness such that there was no need for infill by making the thickness of the part an exact multiple of the nozzle diameter. However, the slicing software would introduce infill as the overhanging angle increased due to the way the slicer operates. An increased angle causes the 2D slice to be thicker than the nominal thickness of the part, and so increasing the shell thickness had the effect of preventing the infill from being created.

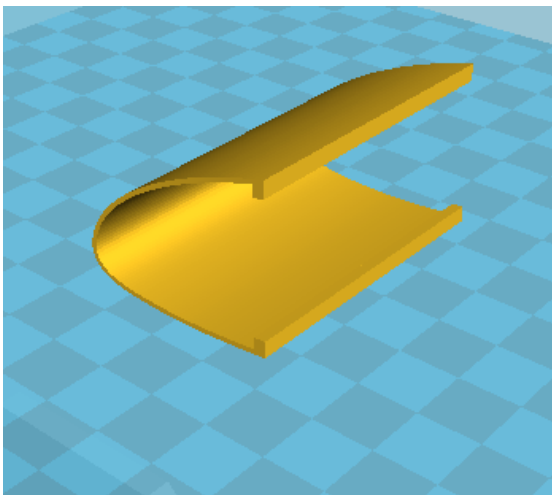

Figure 61: Leading Edge Orientation 2

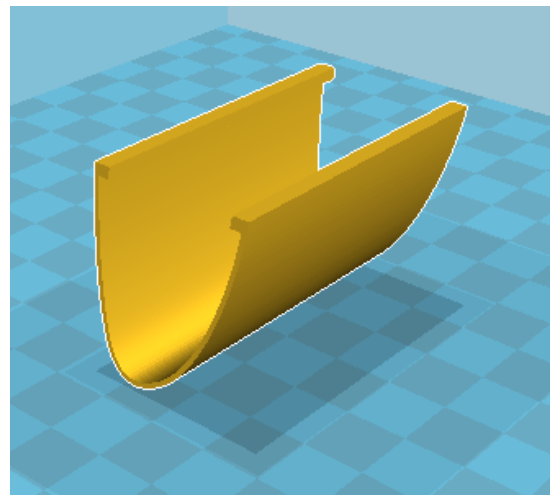

Figure 62: Leading Edge Orientation 3

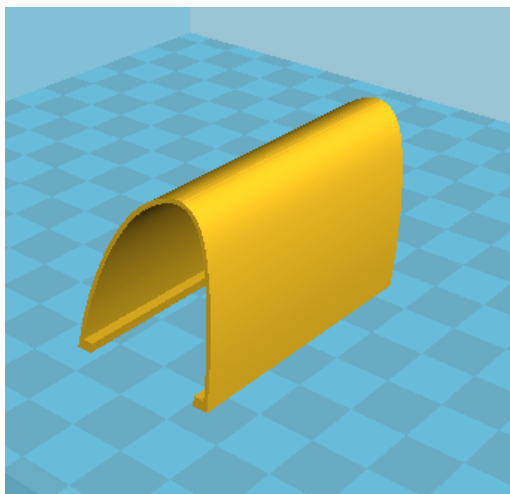

Figure 63: Leading Edge Orientation 4

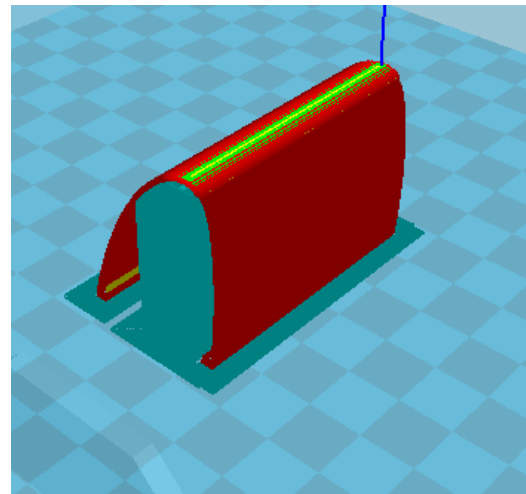

Figure 64: Leading Edge Orientation 4 with Support Material and Brim shown

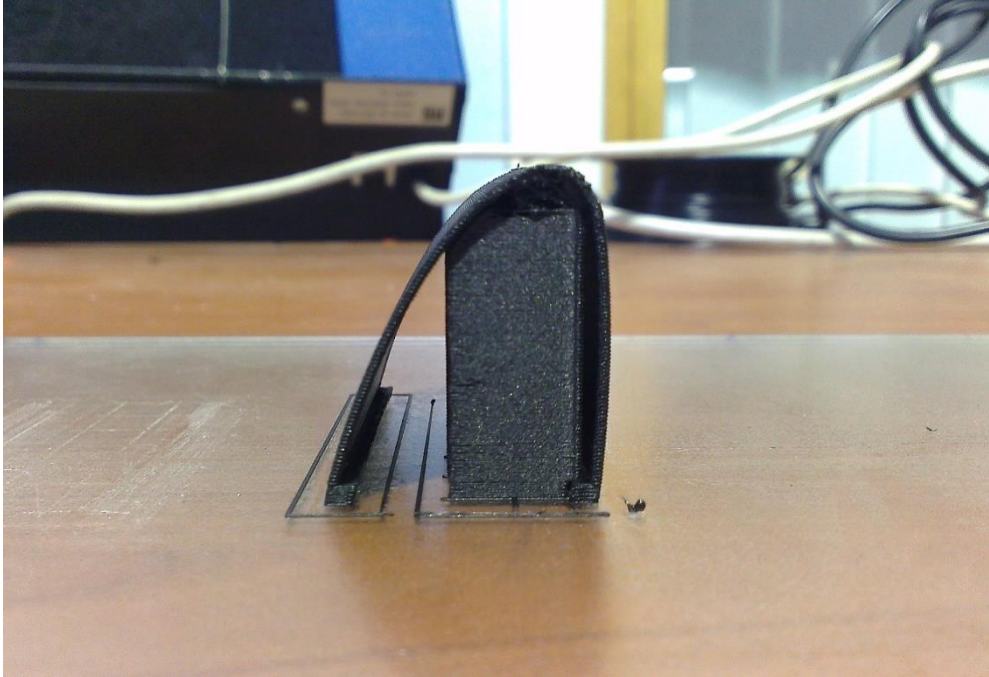

Figure 66: Example of print achieved from orientation 4



Figure 65: Example of poor print performance achieved using orientation 2

Once the optimum printing parameters had been determined, it was possible to produce a section of aerofoil to show the full concept assembled with the ribs connecting the two edge components. The ribs were modified slightly to connect with the leading and trailing edges by an interlocking arrangement. This can be seen in Figure 67 below. The group were happy with the finished concept, with the components fitting together well due to the impressive ability of the printer to

represent geometry accurately. To create a full wing, the concept could easily be expanded, and would be limited only by the length of the print bed. The ribs, although thin, provide the necessary stiffening effect for the assembled components. Two downsides were noted: firstly the weight of the assembly and secondly that the trailing edge piece is not as well locked together as would ideally be the case.

With regard to the weight, this is the main downside of using this as a manufacturing process for such a weight-sensitive application. By its very nature, plastics are significantly more dense than balsa wood, and so are inherently heavier. Although the components were designed to be as light as possible by removing material, the assembly is still somewhat heavier than the balsa equivalent. The second issue can be more readily fixed. It was decided that it would be necessary to fix the components together using some adhesive to lock them in place. This is, in part, necessary regardless of the tightness of the fit of the components since the aerofoil would need to be sufficiently strong to resist the impact of a crash landing.

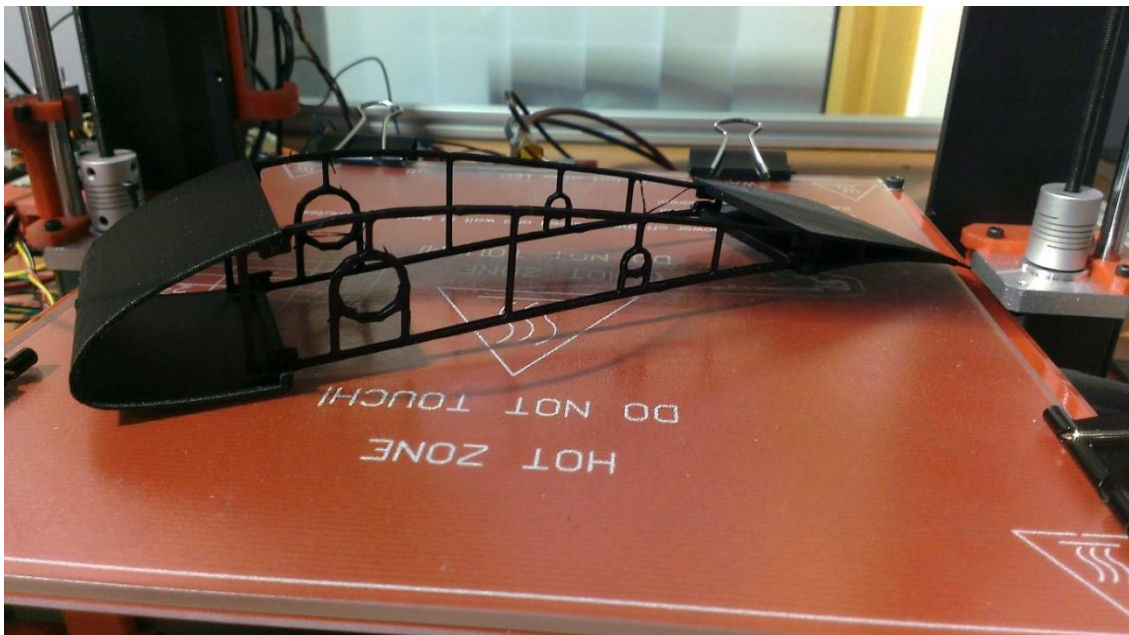

Figure 67: Assembled fully printed aerofoil concept

9.4.3 All in One

The all in one structure was printed from the base up, orientated such that the aerofoil profile was laid out on the base and the layers built up from there as in Figure 68. The internal bracing structure would be built up layer by layer internally, with the outside surface being built up as a solid outer perimeter.

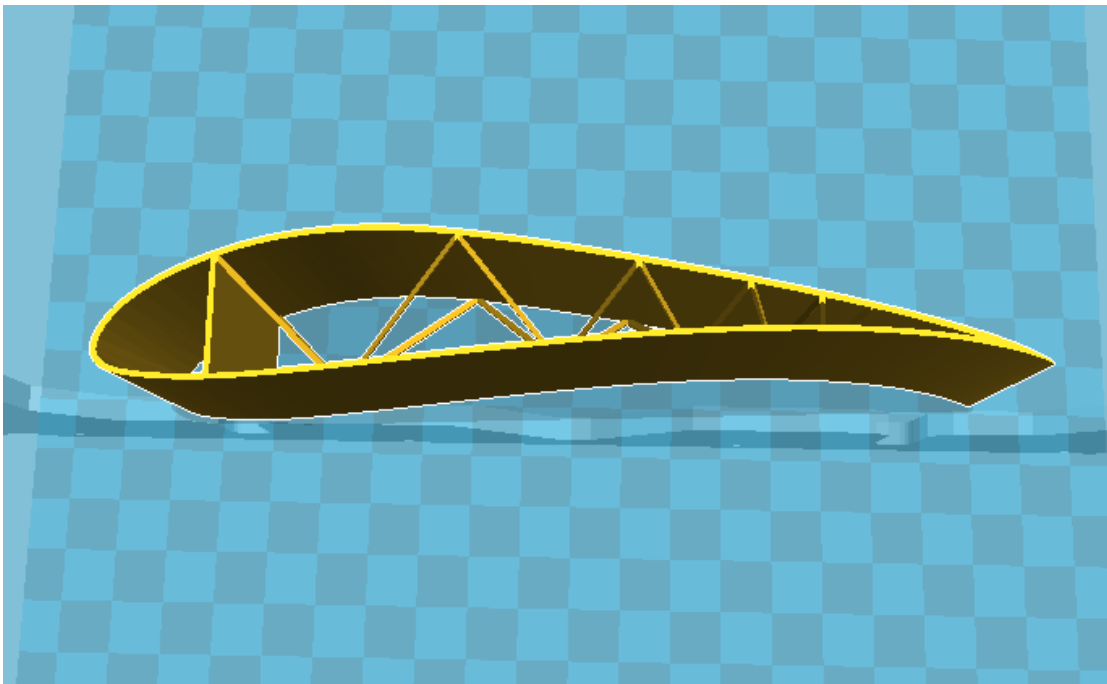

Figure 68: All in One aerofoil Concept orientated as printed

It was found that the internal geometry, being very fine, was very difficult to print successfully. Each of the bracings was a square of 2mm x 2mm in cross-section, and had to be printed into free space as an overhang. This caused issues as a result of the print head moving around to form the different parts of this bracing, whereby the nozzle would collide with the bracings and break them off. Once this had happened once, the print was wasted as any subsequent layers would be fed into space with nothing to lie on top of. It was considered that the introduction of support material would have minimised the likelihood of this problem occurring, however removing the support material from the finished print would likely have caused the same damage.

The other limitation inherent in this concept was that due to its nature there was only one orientation in which printing would be feasible. As a result of this, to print an entire aerofoil would require a printer with a very tall print space, which would be very impractical to achieve and would bring with it other issues. This would include

the fact that due to the moving baseplate, a tall structure could become unstable as the base moved under the nozzle. Any movement in the structure would hamper the print quality, especially where fine geometry is concerned. There was another disadvantage resulting from the orientation, that being that the raster direction would be out of line of the main axis of the aerofoil, and so it would be susceptible to failure at the interface between layers in the event of any impact on the wing.

The combination of the above points led to any further development of this concept being stopped as to achieve an acceptable finished result would result in a far heavier structure than the current balsa wood configuration, and weight is a crucial factor in evaluating the merits of an aerofoil design.

9.5 Conclusions

From the print tests carried out on components, a number of conclusions were made on the ability of the 3D printer to represent different geometries. These are summarised in the sections below.

The printer was effective in printing aerofoil ribs of any form, and provided a quick and reliable means of producing these. The use of composite reinforced filament such as the ProtoPasta Carbon Fibre PLA allowed large amounts of material to be removed giving a finished part that was of similar weight and performance to the balsa wood ribs. 3D printing also facilitates design freedom and allows different configuration of rib to be designed and manufactured quickly and easily. For these types of components, the finished results were not overly dependent on parameters such as the layer height, but 0.2mm was found to be a good balance of stiffness and appearance.

It was found that the printer struggles to create overhanging geometry where the angle of overhang is greater than 45° . This caused the most significant issues when printing the leading edge of the aerofoil because of its gently curved form. This problem is compounded when the part being printed is a thin shell with a gentle curve as the slicing software can induce problems as a result of the way it interprets the 2D slices of the geometry. However, this can be remedied by increasing the shell thickness parameter to prevent the slicer from introducing infill patterns to this region. For curved geometries, the result obtained is far more dependent on the

printing parameters. A layer height of 0.3mm, although giving a faster print time, the results were often poor and the geometry poorly represented. By reducing the layer height to 0.2mm or 0.1mm the quality of the prints was vastly improved, but so also was the print time. It was decided that in most cases, 0.2mm layer height delivered the combination of finished quality and reasonable printing times.

In terms of assemblies, it was found that 3D printing can create parts that fit together well without additional fixings, however the design must consider what the objective of the design is, and how the part will be loaded. It was also found that in the case of an aerofoil, it is difficult to print very lightweight, but sufficiently stiff components compared with the equivalent in balsa wood. However, plastic filaments, particularly with composite fibres, have a far higher stiffness overall and so in more highly loaded applications the benefits of 3D printing will be more pronounced. It is also far more likely to be of significant benefit in less weight-critical applications, where the inherent design flexibility of the process is a major benefit, outweighing the downsides.

10. Analysis of 3D Printed Components

As has been outlined, 3D printing provides the means to manufacture components with a complex form with little tooling beyond the printer hardware. As has also been established, composite reinforced polymer filaments such as the carbon fibre PLA and ABS filaments tested as part of this work, they can bring significant improvements in mechanical performance over the non-reinforced filaments. This provides an opportunity to manufacture components that are to be subjected to more substantial mechanical loading. It would therefore be useful to be able to analyse their performance in a finite element environment before they are printed in order to prove and optimise the design. However, there are a number of hurdles that must be overcome in order to achieve this, which are summarised in the following sections.

10.1 Problems with Analysis

10.1.1 Material Model

Obtaining a material model to be used in any finite element analysis is problematic, particularly so when considering composite filaments as the fibre matrix composition must be known. The tensile strength of the filament can be tested through mechanical testing, however the transformation from the non-extruded to the extruded form may alter the mechanical properties and obtaining the extent to which this is the case is difficult to establish due to the fine geometry of the extruded filament. The finished mechanical properties will also be affected by the thermal processing of the filament as it passes through the heated nozzle, and to account for this would be challenging.

10.1.2 Interface Strength

The other difficulty inherent in undertaking finite element analysis of 3D printed structures is accounting for the interaction between filament passes within the analysis model. This is crucial in gaining meaningful analysis results, since the interaction between layers has heavy influence on the performance of the printed part, since the primary location at which failure will occur in printed components is the interface between different parts of material. This was observed to be the case when printing components such as the leading edge, as when loaded the part would always break at the layer interface.

To establish the strength of the interface is tricky and is highly dependent on the filament being used and the printing parameters such as the extrusion temperature. It is possible that weak bonds will be formed between two passes if the extrusion temperature is too low, and thus the material does not bond to the adjacent material adequately to provide good strength. The atmospheric conditions surrounding the printer will also affect this, as if the material cools very quickly as it leaves the nozzle it may not retain enough of an ability to flow in order to form a good bond. This effect was shown to be significant in some cases from the microscope analysis, from which it can be seen that the internal structure of a printed component can be very different to that which would be expected, with it being far less consistent throughout.

Accounting for this before printing at the analysis stage is a complex task and would require a large amount of experimental testing to establish the strength of this interaction under different printing environments and combinations of printing parameters. It would also be specific to each filament, and potentially printer hardware, thus requiring a vast number of combinations to be considered. This was deemed to be out with the scope and timescale of this project, but would be an interesting investigation to be undertaken should this project be taken forward.

Some work on this area has been undertaken by Dr. Mike Lee of AlphaSTAR Corporation, in the application of 3D printed structures on a larger scale such as car body panels [19]. His research has gone some way to devising a method of predicting layer delamination, by a method that discretises the GCode file into an FEA mesh. Due to the small layer height involved relative to the size of the components, the resulting mesh is one with high resolution in the layers and thus a large number of elements overall. This has the downside of making the analysis process extremely resource intensive, particularly for large structures. If this process could be scaled down to small components it may be possible to undertake such analysis with modest computer processing power.

10.1.3 Slicing and Raster Orientation

The slicing process sets out the order in which material is deposited to form the component, and is wholly dependent on the geometry being produced. This presents issues when considering the feasibility of creating a general process for analysing 3D

printed structures as it has such a dependency on the shape of the component and the printing parameters being used. The consequence of this in the printed components is that there will sometimes be weaknesses in the structure where either a filament pass has been started or finished, or where the nozzle has moved to introduce infill in certain areas. With respect to infill, the shape and percentage of infill selected will also be important to consider.

10.1.4 Composite Filaments

In the case of printing with composite reinforced filaments, such as the carbon-fibre PLA used in this project, consideration should be made of the composite nature of the polymer in any analysis undertaken. To properly achieve this, the characteristics of the filament must be known, such as the properties of the fibres (fibre length, orientation, quantity, strength, etc.), but also of the base polymer. It could be assumed that if the properties of the bulk filament in its printed form are known, then the internal structure and composition could be taken as irrelevant and the material treated as being isotropic.

10.2 Conclusions

To undertake finite element analysis of components to be 3D printed, and achieve a realistic representation of the component has challenges that there was not time to tackle as part of this project. However, thought was given to identifying potential methods to overcome these issues.

It was considered that the geometry could be prepared in the slicing program as normal for printing, but then instead of exporting to GCode for the printer, the toolpath could be exported as a geometry file that included the details of the deposited filament. It was thought that this file could then be imported into an FEA environment such as ANSYS to perform the analysis. It would be necessary to define the material properties as those of each strand of material, rather than the bulk properties of the overall part. The interface force between all the different passes of material would have to be determined as a property within the analysis model. This would be a similar process to the analysis of a multi-layered composite material, and it may be possible to adapt analysis methods for this type of material to the application of 3D printed components.

11. Project Conclusions

A number of conclusions were drawn from the individual aspects of this project. This section summarises the findings of the different sections.

In terms of the testing phase of the project, it was found that introducing chopped carbon fibres into the filament gave rise to a higher stiffness in the tensile test specimens, with the tensile modulus being significantly improved in these cases. Additionally, the weight penalty for the introduction of fibres was negligible and so the strength-to-weight ratio for parts printed using the carbon fibre filament is improved over the case of the plain filament.

The effects of printing layer height on the strength of components was found to have less of an influence than had been expected, and this allowed the conclusion to be drawn that using a larger layer height reduced printing time while not seriously hampering the mechanical performance. However, since the specimens tested were of a simple geometry the implications of using a larger layer height on the geometry representation were not significant.

The findings of microscopy analysis on printed specimens showed that increasing the layer height led to an increase in the presence and size of voids in the finished component. This is undesirable in most cases where load bearing is a consideration and so keeping the layer height small is beneficial to achieve a good finished result. The microscopy analysis also showed that the first layers of the printed structure will be distorted if the nozzle height is not precisely set above the print surface. The printer used in this project had limited capability to achieve this, since the calibration of the print head was a manual process, and this may be less of a consideration on high end hardware with self-levelling capabilities.

It was found that in terms of the printing of components with a low-end 3D printer, there is potential to achieve very good results, however it is highly dependent on a number of factors. Consideration of the printing process must be made when designing the component and further consideration made to the orientation of the component to achieve the desired characteristics. This is because the strength of the component is dependent on the direction of the fibre orientation, especially on parts that have overhanging or curved features. However, the use of carbon fibre

reinforced filaments in the application of printed components presents an exciting opportunity to create parts with good stiffness, while allowing significant design flexibility.

12. Future Work

The project identified a number of areas where there is significant potential for future work to be carried out, expanding the research of this project into other areas to obtain further insight into the characteristics of 3D printed structures.

12.1 Printer Expansions and Upgrades

As one objective of the project was to investigate 3D printing as a means to create functional parts, expansion and upgrade of the printer would be a recommendation to allow larger prints to be created. The goal would be to allow large parts to be printed in one piece, which in turn would allow more work to be undertaken regarding investigation into the functional performance of larger components. To achieve this, a number of upgrades are proposed, which are summarised below.

12.1.1 Increase Print Volume

The most obvious upgrade would be to increase the printing volume, by increasing the area of the print bed, and also the height of the print volume. It would be of more benefit to scale up the x and y axes of the printer as opposed to the z axis, as increasing the height greatly would indeed result in a larger print volume, however the time taken to complete tall prints would be vastly increased. The increase in size would require a number of factors to be considered.

Firstly the increase in size could necessitate an upgrade to the heated bed, to allow a larger print surface. Additionally, since the print head would be moving larger distances, the stepper motors may need upgraded to maintain the performance displayed by the small printer. This combination could require the power supply to be further upgraded, and the Arduino controller upgraded to be able to handle the increased demands. This upgrade may also allow the printer to operate at higher speeds, potentially reducing the print time for very large components, but again the power supply considerations would apply.

It would also be recommended to investigate upgrading the threaded rods used to control the z-axis, since in the current printer these are very basic and low quality parts. Many high end printers utilise trapezoidal screws rather than threaded rods, allowing for more precise control over larger distances. They are also less susceptible to bending, a major benefit over the current components.

12.1.2 Introduction of a Dual Extruder

For printing large or complex parts, it is likely that the introduction of support material will be required to prevent the structure from warping or collapsing as it is printed. Since the composite filaments are a premium product over the standard filaments, limiting their use is beneficial, and so ideally they would not be used as support material as was the case in this project, printing the aerofoil components.

The addition of a second extruder or replacement of the current extruder assembly with a dual extruder version would go some way to facilitating this. The second extruder could be used to deposit a filament to be used for support material, leaving the main extruder to feed the reinforced filament. The support filament could be either a standard plastic filament or a flexible or water-soluble filament, either of which would provide easy removal on completion of the part. The other opportunity that a dual extruder brings is the ability to reinforce specific areas of the component with a composite filament, while using a normal filament for the majority of the part. This would bring the benefit of only using the more expensive filaments where they were required, presenting a potential saving on large parts.

12.1.3 Increased Nozzle Diameter

In addition to the previously proposed upgrades, if the scale of the components is increased to a level where printing them with such small layers would make them uneconomical to produce in terms of time, utilising an extruder with a larger nozzle diameter would allow larger prints to be achieved in a lower time. This is because the amount of material that can be deposited in each layer is improved, and thus the speed of the extruder movement can be increased. The downside of increasing the nozzle diameter is that the range of filaments available is reduced, as large nozzles are less common. The filament diameter must be matched to the nozzle diameter. Currently, the standard nozzle size is approximately 0.4mm, and the filament

diameter 1.75mm. To maintain this ratio for larger nozzles would require significantly increased filament diameters.

Any further work undertaken with regards to printing very large components and increased nozzle diameters should consider the Volcano system developed by e3d⁴. They have developed extruders with nozzle diameters up to 1.2mm, presenting exciting opportunities regarding high speed printing of large parts.

12.2 Testing of Printed Structures

Throughout the duration of the project, a number of combinations of slicing parameters and build conditions were identified by the group and that would affect the mechanical properties of printed parts, along with a number of studies in existing literature being identified. However, combinations of only two slicing parameters were investigated during the project due to time constraints: the effects of layer height, and raster orientation. As the part is known to have anisotropic properties, future work may consider the effects of other parameters and most importantly the build direction of a printed part to achieve optimum strength and stiffness characteristics.

Furthermore, results from the microscopic analysis undertaken by the group leads to a finding of air gaps between each raster, which was then identified later to be one of the major factors contributing to the mechanical properties of a part. Air gaps within a printed part would affect the solidity of a part, which then influences the effective load carrying area, thus affecting the mechanical properties. Within a printed part air gaps are normally found between two rasters, in between a raster and the perimeter, or both.

In general, it is crucial for the future work to utilise the microscopic view of a part in order to alter the slicing parameters and build conditions to obtain the best properties, performance and quality of the printed part.

Further investigation to characterize the printed parts could be made by other mechanical testing such as flexural testing, impact testing and fatigue testing for a better understanding on the mechanical properties and performance of the part.

⁴ http://e3d-online.com/blog/volcano_release [accessed Feb 2016]

13. Reflection on Group Performance

The following sections are set out to evaluate the performance of the group, reflect on what was learned throughout the project and identify where improvements could have been made.

13.1 Achievement of Project Objectives

For the most part the group completed the objectives set out in the initial stages of the project. The group successfully carried out a large number of material tests on a range of configurations and parameter combinations. This gave the group a large amount of data from which conclusions could be drawn about the mechanical properties that could be achieved, as well as a large number of samples which could be analysed to establish the reliability of the printing process through microscopy analysis.

Some objectives had to be adjusted to account for unforeseen complications to the tasks set out initially. The main change to the original scope was that the idea of expanding the printer to allow bigger prints to be created was considered to be a task that had a high potential for introducing further delays to the project at a stage where the timeline was being stretched due to the issues that were being encountered with achieving reliable prints. The group approached the project supervisor to explain the reasoning and background backing up the suggestion, and it was agreed that this was a sensible course of action. Additionally, at this point, the group re-evaluated the number of parameter combinations that were to be tested as the time delays were being encountered in getting the specimens printed.

Overall the group were effective in keeping track of the objectives and maintained a good relationship with the supervisor to let him know of the issues that were being encountered, and mutual decisions were made on the course of action to be taken. It was noted that if the project was to be repeated then setting out the objectives of the project with a better understanding of the timings involved would be beneficial. However, given the fact that the group was new to 3D printing on this scale, this was somewhat unavoidable in this case.

The group faced an obligatory disturbance in schedule with multiple complications from printing up to testing process. During the printing process, the time taken to

achieve optimal printing conditions was underestimated. Even though a strategic approach was taken in tackling this complexity, the optimum print quality was achieved based on time consuming repeated printing trial.

During the testing process, as the testing machine was shared with other students, testing was subject to time constraints. Furthermore, during the filament testing process, the group faced difficulty in obtaining the best set up for the filament test. As there were no standard available, multiple filament set up was configured but had failed. The testing schedule was also disrupted by the breakdown of the main tensile testing machine within the department, and this delayed the final stages of testing. The group had been proactive in ensuring that the testing machine was booked well in advance and so the impact of this breakdown on the group was, thankfully, limited. Also, by identifying this as a risk in the early stages of the project, alternative arrangements were made as soon as the group were made aware of the situation and testing moved to another machine. However, due to its limited size it did not afford the same capabilities to the group.

The group would have liked to achieve slightly more in terms of analysis of printed structures, however in the timescale available it was not possible to fully explore the potential in this respect. The group had underestimated the complexity that would be involved in undertaking analysis, and so failed to account for this in the initial scope and timeline. The number of variables involved in developing an analysis procedure was underestimated, but the work undertaken did identify exciting opportunities in this field, and the group would recommend any group taking this work further should explore this area of research in detail.

13.2 Group Structure

The group structure employed by the group was effective throughout the course of the project and did not present any significant issues. Considering that before this project the group members did not know each other, and two members of the group were new to the University, the group got on well together and there were no issues on this front. The diverse background of the group members made for an interesting and strong group dynamic, with each individual having a different perspective from which could contribute to the project.

The structure of the group drew on the experience and differing backgrounds of each individual in it, utilising their knowledge and skills to the best degree. The result of this was an effective team that worked to achieve the goals of the project effectively, as well as identifying areas where the work could be expanded. Where there were weaknesses in the skill set of the group members, all members worked together to support the others through the project.

13.3 Communication

The group communicated effectively throughout the course of the project. By having a comprehensive communications plan the group maintained regular contact for the entirety of the project, communicating ideas and providing progress updates to the rest of the group. The instant chat group that the group utilised was an ideal way to maintain very regular and informal communication between the members, and provided a means of getting fast replies to queries or issues that were being encountered. This was an invaluable tool and was the most used method of communication. The project manager also utilised weekly update posts within the project Facebook group to provide updates on the progress, activities to be prioritised, and any challenges or problems that were being encountered. This was effective in that it formalised the activities to be completed and with the commenting ability, other members could respond in a trackable and easily viewed manner.

The nature of the project involved spending a lot of time in the workshop, and so the group maintained regular face-to-face contact on both a formal and informal level. This provided an excellent means to collaborate on activities and communicate ideas and thoughts, as well as debate in a manner more effective than through electronic communication.

Furthermore, the group kept in regular contact with the project supervisor through both e-mail and personal interaction. This combination allowed the group to communicate ideas, concerns or other queries relating to the project as well as allowing the supervisor to voice his ideas to the group, where they could be discussed and a course of action decided upon.

13.4 Overcoming of Challenges

On the whole the project ran fairly smoothly, but of course there were hurdles that had to be tackled along the way. In these cases, the group worked together to devise solutions to the issues being encountered. The effectiveness of the group working together to overcome issues was demonstrated a number of times throughout the project.

Early on in the project the group had significant issues achieving reliable prints of the tensile test specimens as they were not sticking to the build plate well enough, and were warping and becoming unstuck before the print completed. It was becoming apparent through progress reviews that this problem was causing the schedule to slip, and so finding a solution to the issue was set as a priority. At this stage all members contributed ideas as to ways to overcome this, and a lot of time was spent in the lab testing these ideas to investigate their effectiveness. This included using different print bed surfaces, different coatings for the print surface, different calibrations and different print parameters. Testing these different combinations was an unforeseen task and required the whole group to contribute to complete the task.

Another issue that was encountered was the testing of the individual filaments, particularly the carbon fibre PLA filament. Due to the brittle nature of this filament it was not possible to mount the filament on the tensile testing machine using the usual arrangement, and so other options had to be identified and tested. The group members proposed a number of ideas that were tested in turn to check if they were suitable or not. Eventually a set up that worked was found and this was utilised to carry out the testing.

13.5 Time Management

The group feel they were quite effective in keeping on track with the project overall, however on reflection the project could have been more effectively time-managed and more use made of project management tools, such as Microsoft Project software.

The time management strategy employed kept track of the project tasks and overall timeline, but this was kept as quite a high level plan on the Gantt chart in Microsoft Project. This was the case as the group members felt that the software was not very user friendly, and frustrating to use due to the way it handled some tasks, particularly

those occurring in parallel. Reflecting back, the group and particularly the project manager, should have spent more time getting familiar with this software so that it could have been utilised to its full potential, or explored other project management software options that are available to find one that suited the needs of the group. Had this course of action been taken, a more detailed timeline could have been maintained and individual tasks managed more effectively.

13.6 Reporting

Producing reports for the project was found to be a more time-intensive task than had been anticipated, and producing the interim report ended up being quite a last-minute task, particularly the final stages of proof-reading and formatting. Three of the group members do not have English as their first language, and so an increased level of proof reading and copy-editing was required. For the interim report this ended up being an unforeseen and sizable task for Andrew to undertake by himself. This was raised as a discussion point in the interim assessment, where the assessors (Dr. Edmondo Minisci and Professor Margaret Stack) reminded the group that it was the work of four individuals and so it was to be expected that there would be variation in writing levels, and that it is important to retain the character of individual sections in a project such as this.

For the final report, the group learned from their experience in the first Semester and allowed more time to compile the report, as well as working on the report as a continuous process. This led to a more relaxed report writing process and proved to be quite effective.

14. References**15.**

- [1] Department of Mechanical and Aerospace Engineering, *ME519 MEng Group Project Module Descriptor Form*, Glasgow: University of Strathclyde, 2015.
- [2] B. Berman, "3-D printing: The new industrial revolution," *Business Horizons*, vol. 55, no. 2, pp. 155-162, 2012.
- [3] Ennex Corporation, "The STL Format," [Online]. Available: http://www.fabbers.com/tech/STL_Format. [Accessed 20 November 2015].
- [4] Slic3r, "Slic3r Manual," [Online]. Available: <http://manual.slic3r.org/expert-mode/infill>. [Accessed 15 March 2016].
- [5] A. Sood, R. Ohdar and S. Mahapatra, "Parametric appraisal of mechanical property of fused deposition modelling processed parts," *Materials and Design*, vol. 31, no. 1, pp. 287-295, 2010.
- [6] A. Bellini and S. Guceri, "Mechanical characterization of parts fabricated using fused deposition modeling," *Rapid Prototyping Journal*, vol. 9, no. 4, pp. 252-264, 2003.
- [7] O. S. Es-Said, J. Foyos, R. Noorani, M. Mendelson, R. Marloth and B. Pregger, "Effect of Layer Orientation on Mechanical Properties of Rapid Prototyped Samples," *Materials and Manufacturing Processes*, vol. 15, no. 151, pp. 107-122, 2000.
- [8] K. Ang, K. Leong and C. Chua, "Investigation of the mechanical properties and porosity relationships in fused deposition modelling-fabricated porous structures," *Rapid Prototyping Journal*, vol. 12, pp. 100-105, 2006.
- [9] S. Ahn, M. Montero and D. Odell, "Anisotropic material properties of fused deposition modeling ABS," *Rapid Prototyping Journal*, vol. 8, no. 4, pp. 248-257, 2002.

- [10] W. Sun, G. Rizvi and C. Bellehumeur, "Effect of processing conditions on the bonding quality of FDM polymer filaments," *Rapid Prototyping Journal*, vol. 14, no. 2, pp. 72-80, 2008.
- [11] B. Lee, J. Abdullah and Z. Khan, "Optimization of rapid prototyping parameters for production of flexible ABS object," *Journal of Materials Processing Technology*, vol. 169, no. 1, pp. 54-61, 2005.
- [12] British Standards Institute, *BS EN ISO 527-2: Determination of tensile properties, Part 2: Test conditions for moulding and extrusion plastics*, British Standards Institute, 2012.
- [13] O. Carneiro, A. Silva and R. Gomes, "Fused deposition modeling with polypropylene," *Materials and Design*, vol. 83, pp. 768-776, 2015.
- [14] L. Baich and G. Manogharan, "Study of Infill Print Parameters on Mechanical Strength and Production Cost-Time of 3D Printed ABS Parts," Department of Mechanical and Industrial Engineering, Youngstown State University, Youngstown.
- [15] L. Li, Q. Sun, C. Bellehumeur and P. Gu, "Composite Modeling and Analysis for Fabrication of FDM Prototypes with Locally Controlled Properties," *Journal of Manufacturing Processes*, vol. 4, no. 2, pp. 129-141, 2002.
- [16] J. Rodríguez, J. Thomas and J. Renaud, "Design for Fused-Deposition ABS Components for Stiffness and Strength," *Journal of Mechanical Design*, vol. 125, no. 3, pp. 545-551, 2003.
- [17] A. Bagsik and V. Schöppner, "Mechanical Properties of Fused Deposition Modeling Parts Manufactured with ULTEM 9085," in *Proceedings of ANTEC (Vol. 2011)*, Boston, 2011.
- [18] A. Fatimatuzahraa, B. Farahaina and W. Yusoff, "The effect of employing different raster orientations on the mechanical properties and microstructure of Fused Deposition Modeling parts," in *ISBEIA 2011 - 2011 IEEE Symposium on Business, Engraving and Industrial Applications*, Langkawi, 2011.

- [19] M. Lee, "The Impact of Fiber Content and Effect of Defects on 3D Printing Car Additive Manufacturing Process," in *Society of Plastics Engineers Automotive Composites Conference 2015*, Novi, 2015.
- [20] bolsoncerrado, "print3dforum," 13 March 2015. [Online]. Available: <http://www.print3dforum.com/showthread.php/385-Unibody-Extruder-on-the-way!>. [Accessed 15 March 2016].
- [21] CAP University, "The CAPInc Blog," 4 December 2014. [Online]. Available: <http://blog.capinc.com/2014/12/design-for-3d-printing-success/>. [Accessed 15 March 2016].
- [22] Avianna, "Craft Unique," 16 February 2015. [Online]. Available: <https://craftunique.com/forums/view-thread/645>. [Accessed 3 March 2016].
- [23] Kods, "mashtips," 9 November 2015. [Online]. Available: <http://mashtips.com/things-should-know-before-buy-3d-printer/>. [Accessed 15 March 2016].
- [24] M. Agarwala, V. Jamalabad and N. Langrana, "Structural quality of parts processed by fused deposition," *Rapid Prototyping Journal*, vol. 2, no. 4, pp. 4-19, 1996.
- [25] British Standards Institution, *BS EN ISO 527-1: Determination of tensile properties, Part 1: General principles*, British Standards Institution, 2012.

Appendix 1: ME519 Project Contract

1. Project Details

Project Title: 3D Printing of Functional Parts and their Structural Integrity

Client: Dr. Tugrul Comlekci, on behalf of the University of Strathclyde, Glasgow.

Start Date: 1/10/2015

Date of Completion: 1/4/2016

2. Terms of Contract

2.1 This contract is entered into and acts between Andrew Gilmour, Fazril Latif, Giovanni Ressurreição Piffer and Martin Gutierrez Benito (hereafter “the Group”) and Dr. Tugrul Comlekci (hereafter “the Client”) on behalf of the University of Strathclyde relating to the 5th year MEng Group Project (hereafter “the Project”).

2.2 This terms outlined in this contract will be effective over the period between 23rd October 2015 and Friday 1st April 2016.

3. Project Background

3.1 3D printing is an emerging technology that is rapidly expanding in popularity and use. Originally the reserve of home tinkerers, its potential is now being realised in real-world, engineering applications.

3.2 The ‘Rep-Rap’ movement has reduced the cost of 3D printing significantly, however the strength of the printed components is questionable due to the relatively low strength of the filaments, and the strength of the bonding between printed layers.

3.3 The other noteworthy development is the increased availability of plastic filaments with enhanced properties due to the inclusion of additional fibres to the filament. These filaments may allow low-cost, DIY 3D printers to print far more functional components.

3.4 It is of interest to the Client to investigate the strength and stiffness properties of 3D printed components, and identify any improvements that can be made through the use of enhanced filaments.

4. Statement of Purpose

4.1 The Client has enlisted the services of the Group to investigate the performance of 3D printed functional components, specifically when using ‘exotic filaments’, plastic filaments with additional reinforcement such as carbon fibre or kevlar.

4.2 The Group will purchase and build a D.I.Y. ‘Rep-Rap’ 3D printer, such as the Prusa i3, to use during the course of the project. The printer used in the project will utilise the Fused Filament Fabrication (“FFF”) method.

4.3 The Group will carry out mechanical testing on a range of basic printed structures to investigate their strength and structural integrity when the printing parameters (layer thickness, infill, filament patterns, etc.) are altered.

4.4 The Group will use the acquired knowledge and apply it to the design of a BMFA aerofoil, to investigate the feasibility of 3D printing the aerofoil structure with reduced weight while maintaining the strength and stiffness of traditionally manufactured, balsa wood aerofoils.

4.5 The Group will identify areas for further, future experimentation with regards to printing complex structures, particularly with exotic filaments.

5. Contractors and Management

5.1 The Group will be made up of the contractors in the table below.

Name	E-mail Address
Andrew Gilmour	a.gilmour.2013@uni.strath.ac.uk
Fazril Latif	muhammad.abdul-latif.2013@uni.strath.ac.uk
Giovanni Ressurreição Piffer	giovanni.ressureicao-piffer.2015@uni.strath.ac.uk
Martín Gutierrez Benito	martin.gutierrez-benito.2015@uni.strath.ac.uk

5.2 Andrew Gilmour will act as Project Manager for the duration of the Project. This will include responsibility for the production of reports.

5.3 Fazril Latif will manage the testing phase of the Project, specifically testing of filaments and printed structures.

5.4 Martin Gutierrez Benito will have responsibility for the upkeep and maintenance/modification of the 3D printer, the printing of structures and the design of test structures.

6. Project Deliverables

6.1 The main deliverables of the project are listed below:

Deliverable	Delivery Time
Functional 3D Printer	Mid November 2015
Interim Report	Week beginning 16 th November 2015
Material/structural testing results	Mid December 2015 (end Semester 1)
3D printed BMFA aerofoil	March 2016
Final Report	End of week 9, 2 nd Semester
Project Website	Week beginning 28 th March 2016
Project Presentation	Week beginning 28 th March 2016

7. Project Resources and Budget

7.1 The 3D Printer will be purchased from funds allocated by the Client.

7.2 An additional £400 of funding has been allocated by the Department of Mechanical and Aerospace Engineering for the Project. The primary use of this funding will be for the purchase of consumables.

7.3 Manufacturing facilities and technicians are provided by the department throughout the duration of the project. The availability of facilities and technicians will affect the completion of this project.

7.4 Suitable workspace is provided by the department. The workspace must be satisfactory in terms of area, condition and safety to accommodate the 3D printer and its related materials.

7.5 Computer facilities and required software are to be provided by the University of Strathclyde.

8. Project Timeline

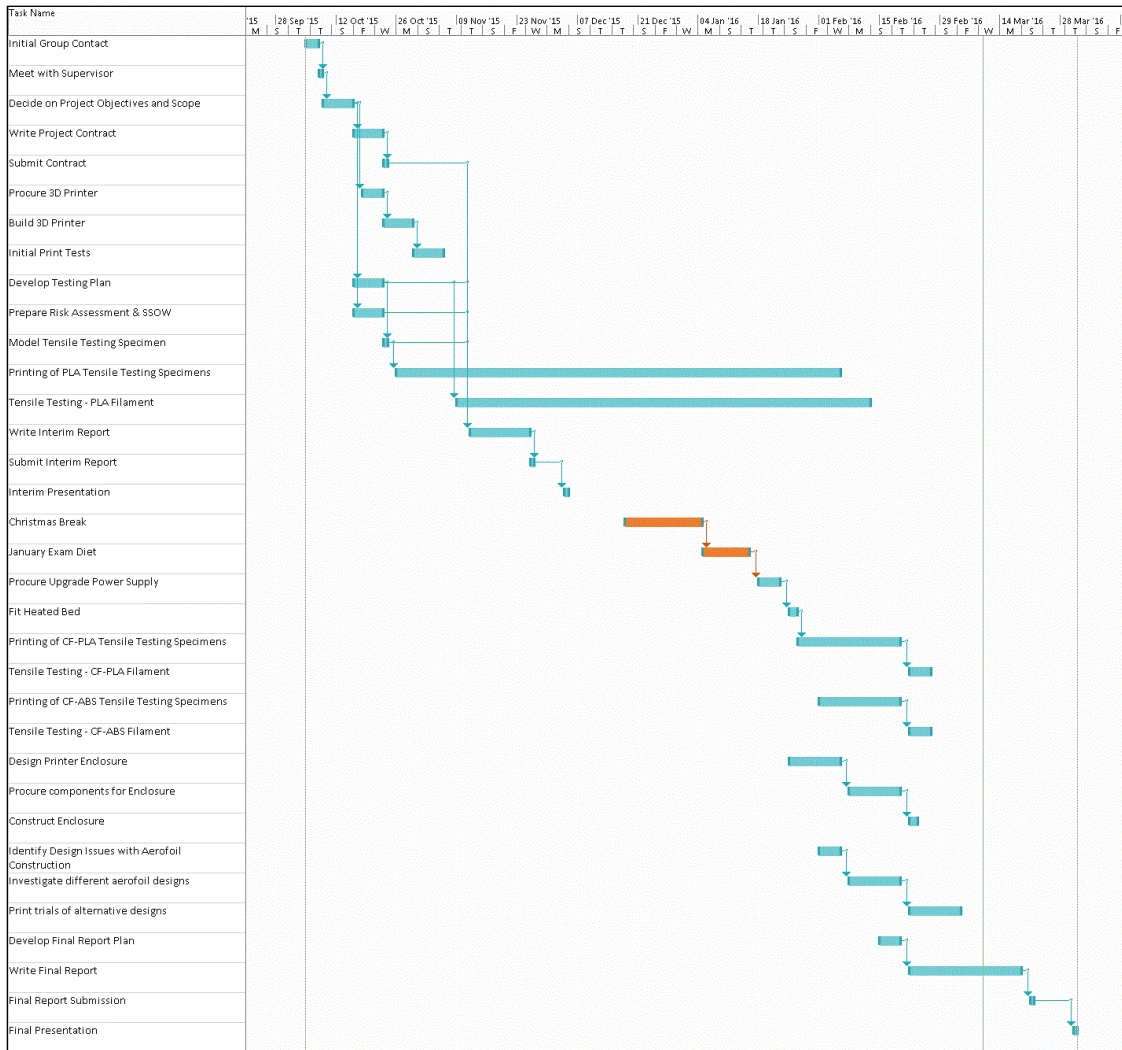

9. Identified Risks to Project

9.1 Table below details the potential risks identified that may delay or negatively affect the quality of the Project deliverables from the Group. The likelihood and severity estimation of the risks have been given in the rating (1 to 5); of which the product of these two values together determine the risk rating. The risk rating score classifies the risk in which 1-3 represents “low” risk; 4-9 represents “medium” risk; 10-16 represents “high” risk; and 17-25 represents “very high” risk. Possible risk reduction actions are also detailed in the table.

Risk	Description	Likelihood, L (1, 2, 3, 4, 5)	Severity, S (1, 2, 3, 4, 5)	Risk Rating (LxS)	Proposed risk reduction measures (if applicable)
Team member illness or injury	Team member illness or injury will limit the human resources available to work on the project and would necessitate redistribution of tasks.	2	3	6	Where possible tasks will be assigned to the absent member that can be completed without being present. They will be kept up to date by electronic communication should they be absent for group meetings.
Supervisor absence	Extended periods of absence of the supervisor may hinder the progress of the project.	1	2	2	
Team member commitments to other projects/classes	There may be times where team members are committed to other class activities (exams, tests, assignments, etc.).	4	3	12	Team members will identify times where this may be the case and communicate these to the other group members, and the schedule can be adjusted to suit.
Lab unavailability	The progress of the project is reliant on the lab space being available. Unavailability could seriously delay the project.	3	5	15	The group will liaise with the lab technician Mr. Chris Cameron to negotiate access times and a designated area in the lab.
Printer failure	The project is reliant on the functionality of the printer being maintained.	3	5	15	The group will operate the printer in line with an agreed safe system of work procedure and risk assessment. Regular inspection and maintenance will be carried out to ensure functionality is maintained.
Testing equipment unavailability	The unavailability of testing equipment may adversely affect the progress of the project.	3	3	9	The Head of Testing will ensure that testing machines are booked in advance by liaising with the lab technician, Mr James Gillespie.
Data loss	Unexpected loss of data could cause delays to the project.	1	5	5	All data should be backed up in multiple locations. A cloud-based storage system will be utilised by group members to ensure the safe keeping of critical files. See communications strategy.
Delay of parts/material delivery	Delays in receiving parts and/or materials may hinder the project progress.	2	1	2	Material should be ordered well in advance of them being required.
Funding	Poor budget management may lead slow progress and failure to meet targets.	1	2	2	The project budget should be managed strictly, and if a problem is foreseen, this should be raised with the supervisor.

Safety of group members	The 3D printer has many moving parts and high temperature components that could pose a risk to group members or other lab users, or damage the printer, thus delaying the project.	2	2	4	The group shall ensure to adhere to the University's Health and Safety requirements and ensure a risk assessment is completed. It may be necessary to enclose the 3D printer.
-------------------------	--	---	---	---	---

9.2 Group members Fazril Latif, Martin Gutierrez-Benito and Giovanni Ressurreição Piffer reside out with Scotland and will be unavailable over the break between end of Semester 1 and the beginning of Semester 2.

Contractors	Unavailability period
Fazril Latif	14 December 2015 – 15 January 2016
Martin Gutiérrez Benito	14 December 2015 – 15 January 2016
Giovanni Ressurreição Piffer	12 December 2015 – 15 January 2016

10. Client Obligations

10.1 The Client agrees to support the Group with their work, and will be contactable by e-mail, or other means to respond to queries relating to the Project.

10.2 Should the Client become unavailable for any reason (due to other commitments, illness, etc.) they will make the Group available at the earliest possible opportunity and make arrangements for this period of absence.

10.3 The client will provide to the Group any resources they have that relate to the work being undertaken as part of the Project.

11. Declaration

11.1 By signing this document the Group agrees to the terms outlined in this contract and will be responsible for ensuring the objectives are met in line with the specified timeline.

11.2 By signing this document the Client agrees to the terms outlined in this contract.

Signed Client:

Dr. Tugrul Comlekci

Date: _____

Signed Contractors:

Andrew Gilmour

Date: _____

Fazril Latif

Date: _____

Giovanni Ressurreição Piffer

Date: _____

Martín Gutierrez Benito

Date: _____

Appendix 2: Test DataBQ-PLA-DIAGONAL**0.1 mm layer height:**

Sample	Tensile Strength (MPa)	Tensile Strain (%)	Tensile Modulus (GPa)
1	46.34	2.12	2.90
2	48.36	2.17	3.11
3	46.08	2.16	3.04
4	43.74	2.51	2.91
5	48.07	2.21	3.24
average	46.52	2.23	3.04
standard deviation	1.85	0.16	0.14
counts	5	5	5
95% CL	1.62	0.14	0.12

0.2 mm layer height:

Sample	Tensile Strength (MPa)	Tensile Strain (%)	Tensile Modulus (GPa)
1	39.72	1.96	2.38
2	43.07	3.26	3.14
3	43.64	2.22	2.94
4	40.46	2.14	2.96
5			
average	41.72	2.39	2.85
standard deviation	1.92	0.59	0.33
counts	4	4	4
95% CL	1.89	0.57	0.32

0.3 mm layer height:

Sample	Tensile Strength (MPa)	Tensile Strain (%)	Tensile Modulus (GPa)
1	42.40	2.29	3.02
2	44.11	1.89	3.54
3	45.70	2.11	3.01
4	42.30	2.39	2.88
5	42.41	1.94	2.56
average	43.39	2.13	3.00
standard deviation	1.50	0.22	0.35
counts	5	5	5
95% CL	1.31	0.19	0.31

BQ-PLA-LINEAR**0.1 mm layer height:**

Sample	Tensile Strength (MPa)	Tensile Strain (%)	Tensile Modulus (GPa)
1	51.96	1.49	3.61
2	55.72	2.21	3.22
3	55.66	2.00	3.94
4	55.97	1.99	3.64
5	55.21	2.09	3.69
average	54.90	1.95	3.62
standard deviation	1.67	0.28	0.26
counts	5	5	5
95% CL	1.46	0.24	0.23

0.2 mm layer height:

Sample	Tensile Strength (MPa)	Tensile Strain (%)	Tensile Modulus (GPa)
1	52.14	2.16	3.24
2	54.99	2.15	3.31
3	53.87	2.20	3.39
4	54.98	2.24	3.55
5	51.04	2.13	3.19
average	53.40	2.18	3.34
standard deviation	1.76	0.05	0.14
counts	5	5	5
95% CL	1.54	0.04	0.12

0.3 mm layer height:

Sample	Tensile Strength (MPa)	Tensile Strain (%)	Tensile Modulus (GPa)
1	48.37	2.38	3.16
2	48.39	2.32	3.11
3	50.12	2.44	3.14
4	50.93	2.35	3.16
5	50.31	2.39	3.50
average	49.63	2.38	3.21
standard deviation	1.17	0.04	0.16
counts	5	5	5
95% CL	1.03	0.04	0.14

PP-CFPLA-DIAGONAL**0.1 mm layer height:**

Sample	Tensile Strength (MPa)	Tensile Strain (%)	Tensile Modulus (GPa)
1	49.91	1.69	5.37
2	48.53	1.76	5.06
3	43.24	1.46	4.85
4	45.54	1.61	5.18
5	43.13	1.44	4.90
average	46.07	1.59	5.07
standard deviation	3.07	0.14	0.21
counts	5	5	5
95% CL	2.69	0.12	0.18

0.2 mm layer height:

Sample	Tensile Strength (MPa)	Tensile Strain (%)	Tensile Modulus (GPa)
1	53.86	1.70	5.19
2	53.60	1.58	5.43
3	53.46	1.60	5.86
4	52.81	1.62	5.47
5	52.71	1.63	5.63
average	53.29	1.63	5.52
standard deviation	0.50	0.05	0.25
counts	5	5	5
95% CL	0.44	0.04	0.22

0.3 mm layer height:

Sample	Tensile Strength (MPa)	Tensile Strain (%)	Tensile Modulus (GPa)
1	50.53	1.58	5.22
2	52.50	1.75	5.28
3	48.29	1.62	5.07
4	45.76	1.62	4.70
5	46.97	1.58	5.32
average	48.81	1.63	5.12
standard deviation	2.72	0.07	0.25
counts	5	5	5
95% CL	2.38	0.06	0.22

PP-CFPLA-LINEAR**0.1 mm layer height:**

Sample	Tensile Strength (MPa)	Tensile Strain (%)	Tensile Modulus (GPa)
1	52.70	1.42	6.39
2	53.44	1.36	6.60
3	53.62	1.46	6.66
4	53.20	1.27	6.77
5	53.29	1.47	6.53
average	53.25	1.39	6.59
standard deviation	0.35	0.08	0.14
counts	5	5	5
95% CL	0.30	0.07	0.12

0.2 mm layer height:

sample	Tensile Strength (MPa)	Tensile Strain (%)	Tensile Modulus (GPa)
1	51.94	1.44	6.20
2	49.89	1.50	5.87
3	54.99	1.52	6.23
4	51.21	1.40	6.78
5	47.81	1.47	5.45
average	51.17	1.47	6.11
standard deviation	2.65	0.05	0.49
counts	5	5	5
95% CL	2.32	0.04	0.43

0.3 mm layer height:

Sample	Tensile Strength (MPa)	Tensile Strain (%)	Tensile Modulus (GPa)
1	48.91	1.38	6.60
2	47.61	1.41	6.58
3	46.63	1.26	6.79
4	47.08	1.61	6.81
5	47.18	1.53	6.13
average	47.48	1.44	6.58
standard deviation	0.87	0.13	0.27
counts	5	5	5
95% CL	0.76	0.12	0.24

OOKUMA-CFABS-DIAGONAL**0.2 mm layer height:**

Sample	Tensile Strength (MPa)	Tensile Strain (%)	Tensile Modulus (GPa)
1	26.37	1.59	3.92
2	27.03	1.59	3.43
3	26.55	1.89	3.58
4	24.57	1.74	3.89
5	26.81	1.60	3.66
average	26.27	1.68	3.70
standard deviation	0.98	0.13	0.21
counts	5	5	5
95% CL	0.86	0.11	0.18